



(19) **United States**
(12) **Patent Application Publication**
Takahara

(10) **Pub. No.: US 2015/0262528 A1**
(43) **Pub. Date: Sep. 17, 2015**

(54) **ELECTROLUMINESCENT DISPLAY**

(52) **U.S. Cl.**

(71) Applicant: **JOLED INC.**, Tokyo (JP)

CPC **G09G 3/3258** (2013.01); **G09G 3/3291**
(2013.01); **G09G 2300/08** (2013.01); **G09G**
2300/0408 (2013.01); **G09G 2310/0286**
(2013.01)

(72) Inventor: **Hiroshi Takahara**, Osaka (JP)

(73) Assignee: **JOLED INC.**, Tokyo (JP)

(57) **ABSTRACT**

(21) Appl. No.: **14/434,851**

The number of control lines to be formed on a COF in serial connection is reduced. An EL display includes a flexible board including: a plurality of connection terminals arranged at one side for connection with panel lines formed on a panel board; terminal connection lines for connecting points inside the flexible board with the connection terminals; serial connection lines for connecting between two or more of the connection terminals. On the flexible board: driver output terminals of each of gate driver ICs are connected to terminal connection lines; driver input terminals of the gate driver IC are connected to either terminal connection lines or the serial connection lines; and control terminals for performing logic setting of the gate driver IC are each arranged between connection terminals and driver input terminals to which the serial connection lines are connected.

(22) PCT Filed: **Oct. 9, 2013**

(86) PCT No.: **PCT/JP2013/006030**

§ 371 (c)(1),

(2) Date: **Apr. 10, 2015**

(30) **Foreign Application Priority Data**

Oct. 17, 2012 (JP) 2012-229448

Publication Classification

(51) **Int. Cl.**

G09G 3/32

(2006.01)

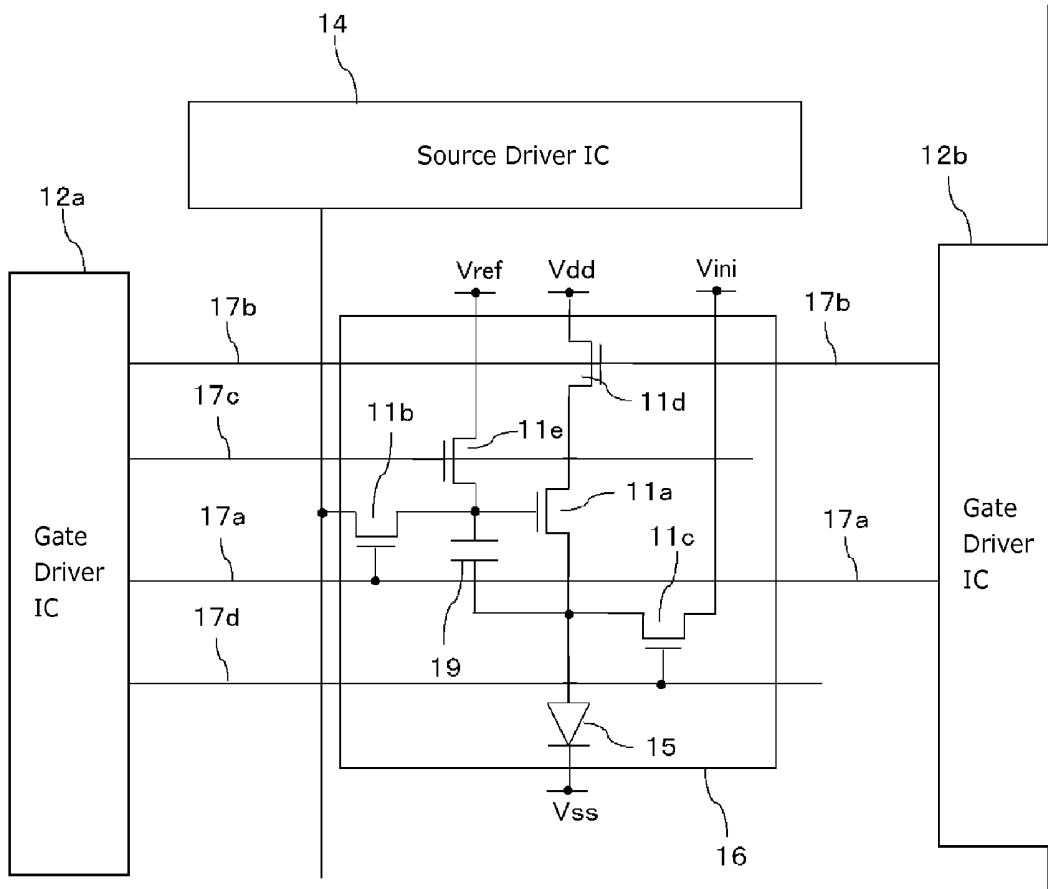

FIG. 1

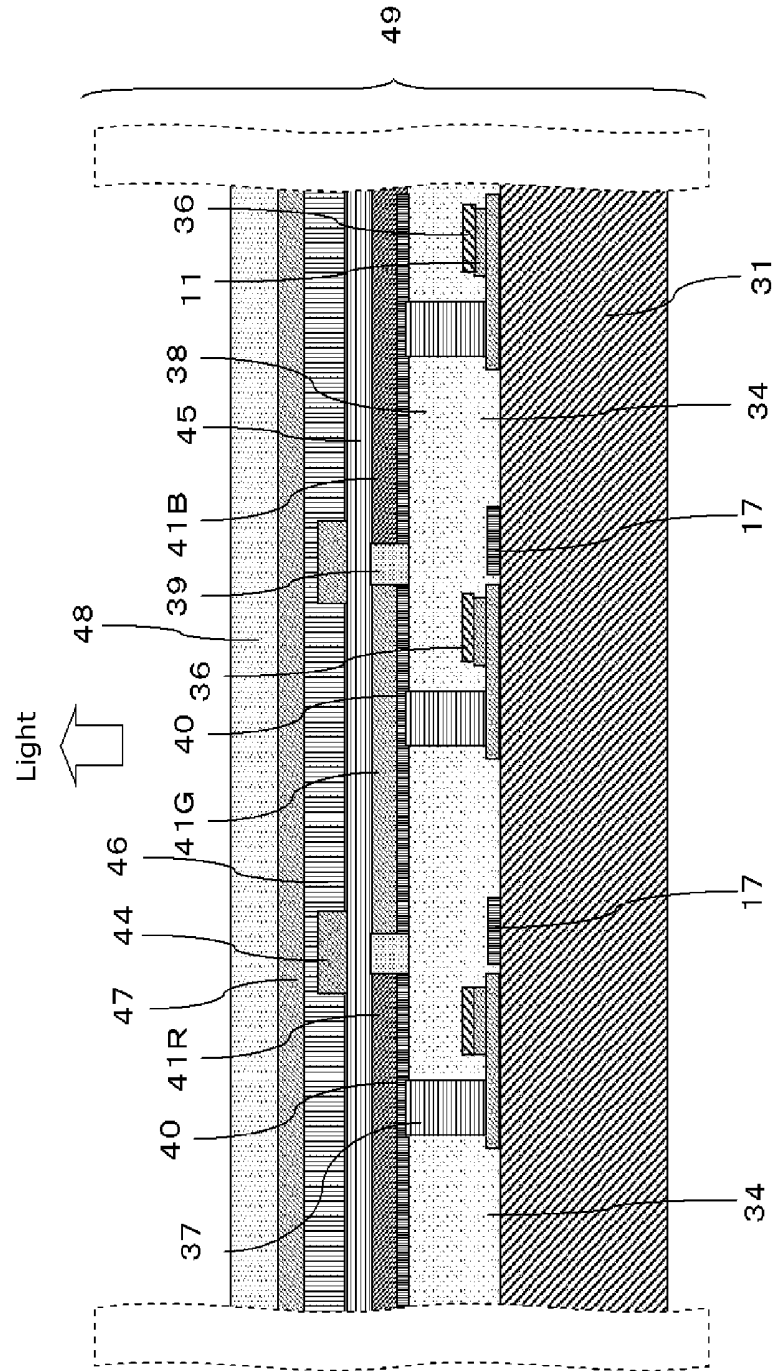

FIG. 2

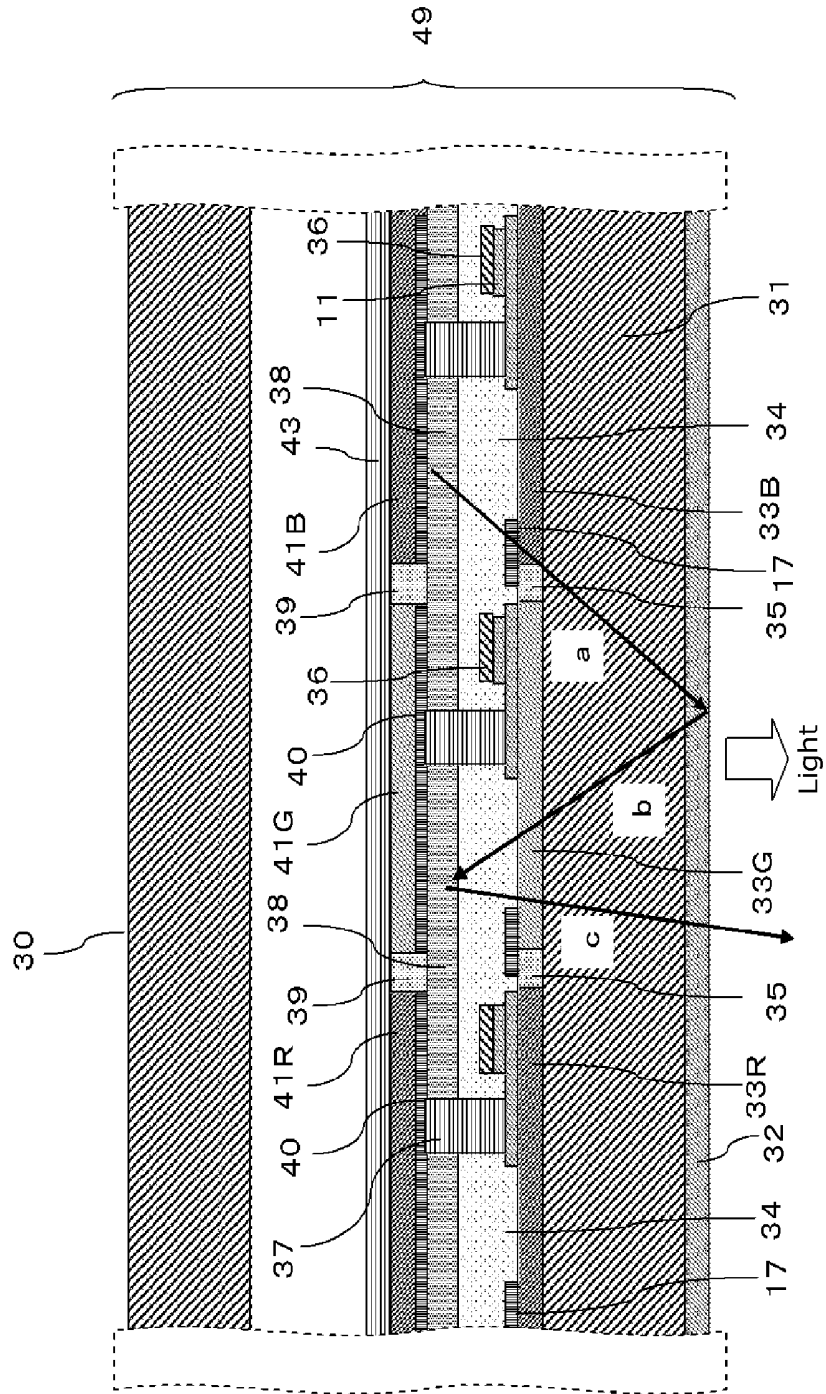

FIG. 3

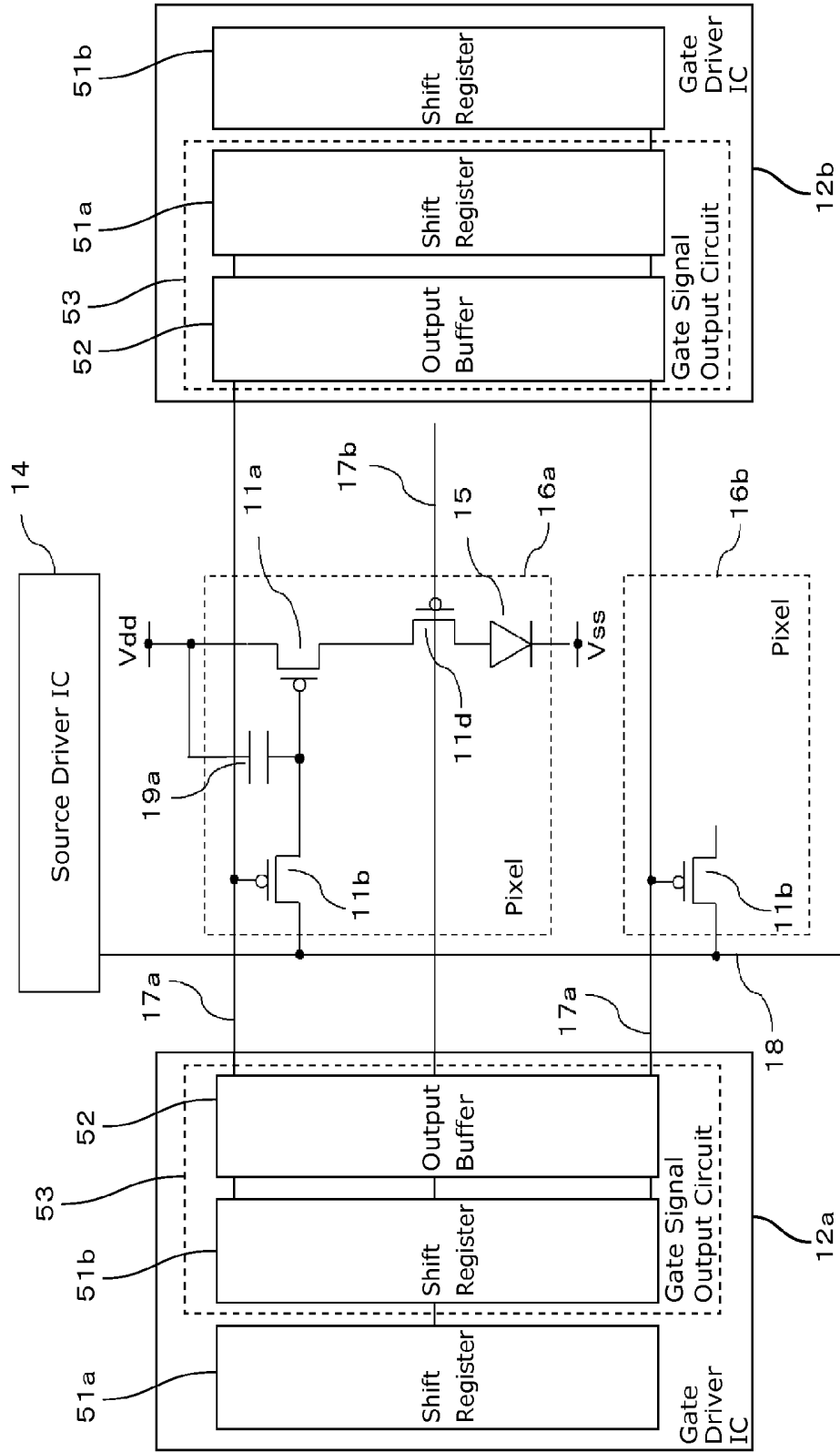

FIG. 4

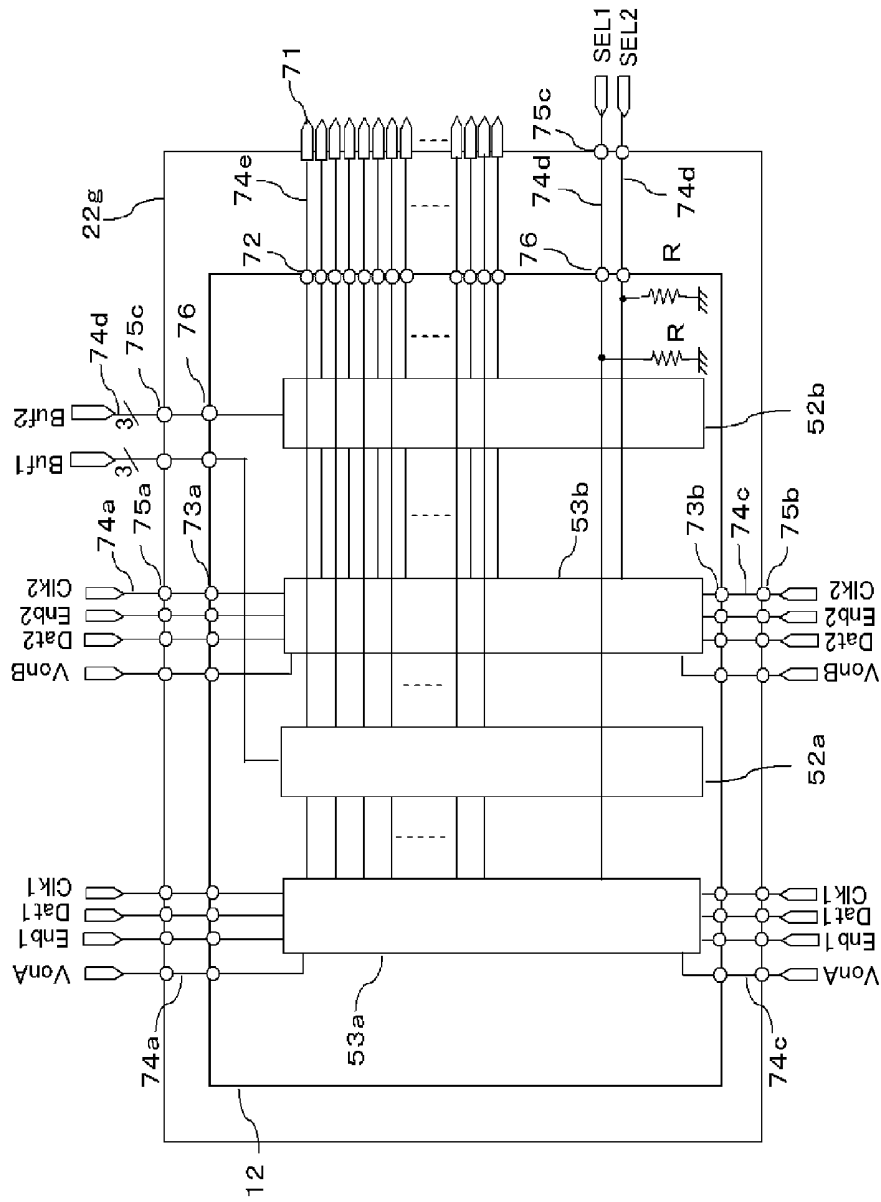

FIG. 5

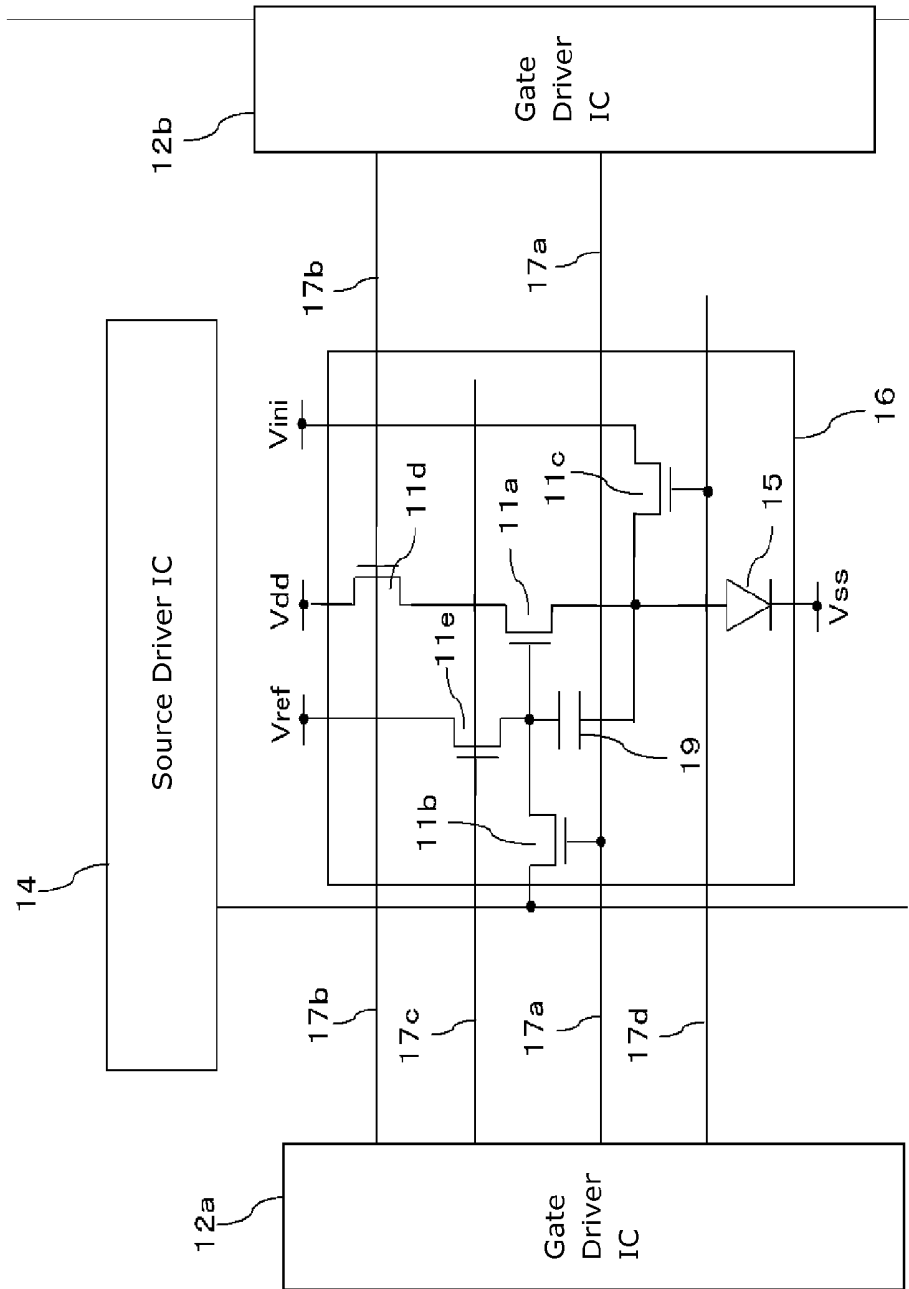

FIG. 6

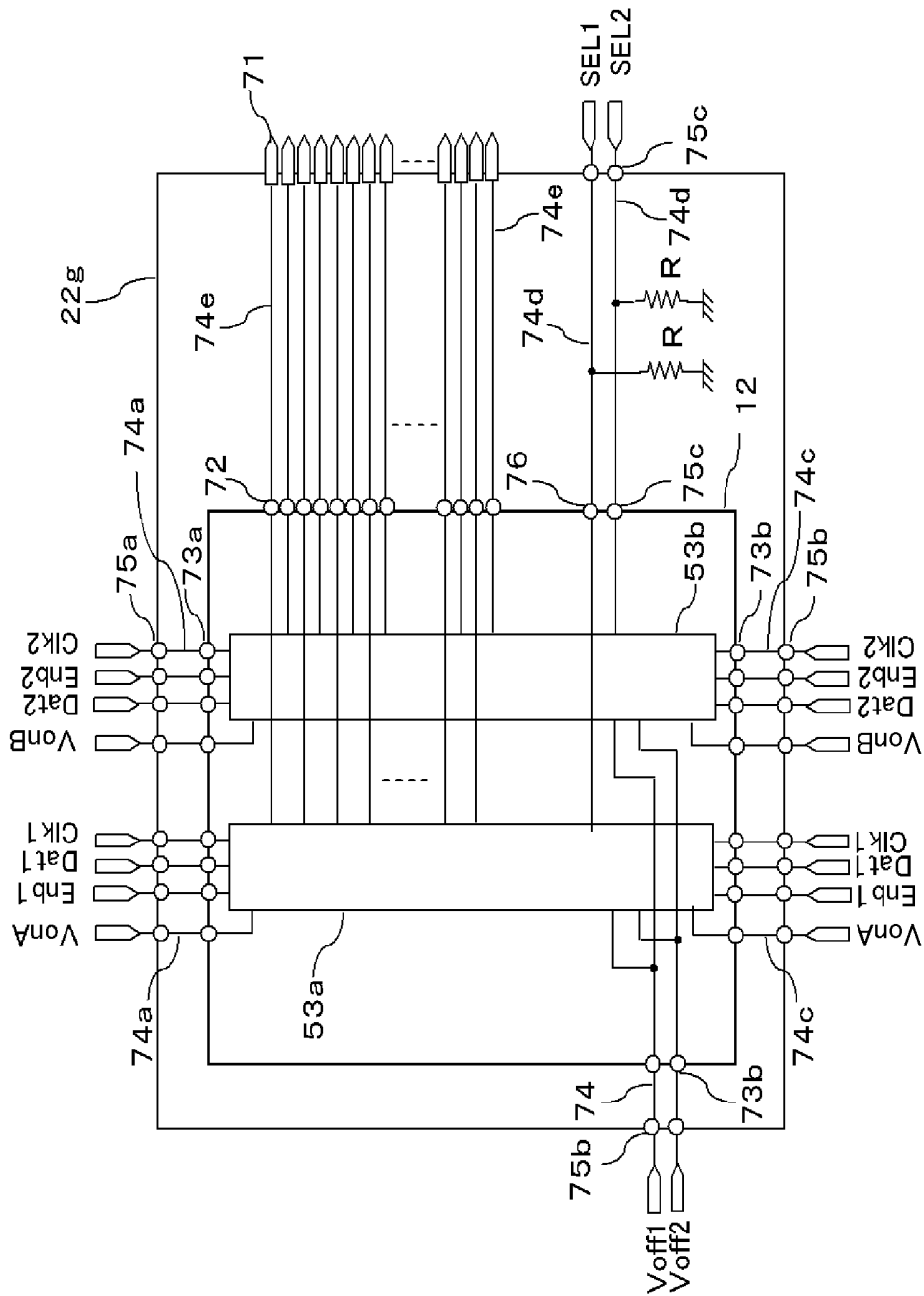

FIG. 7

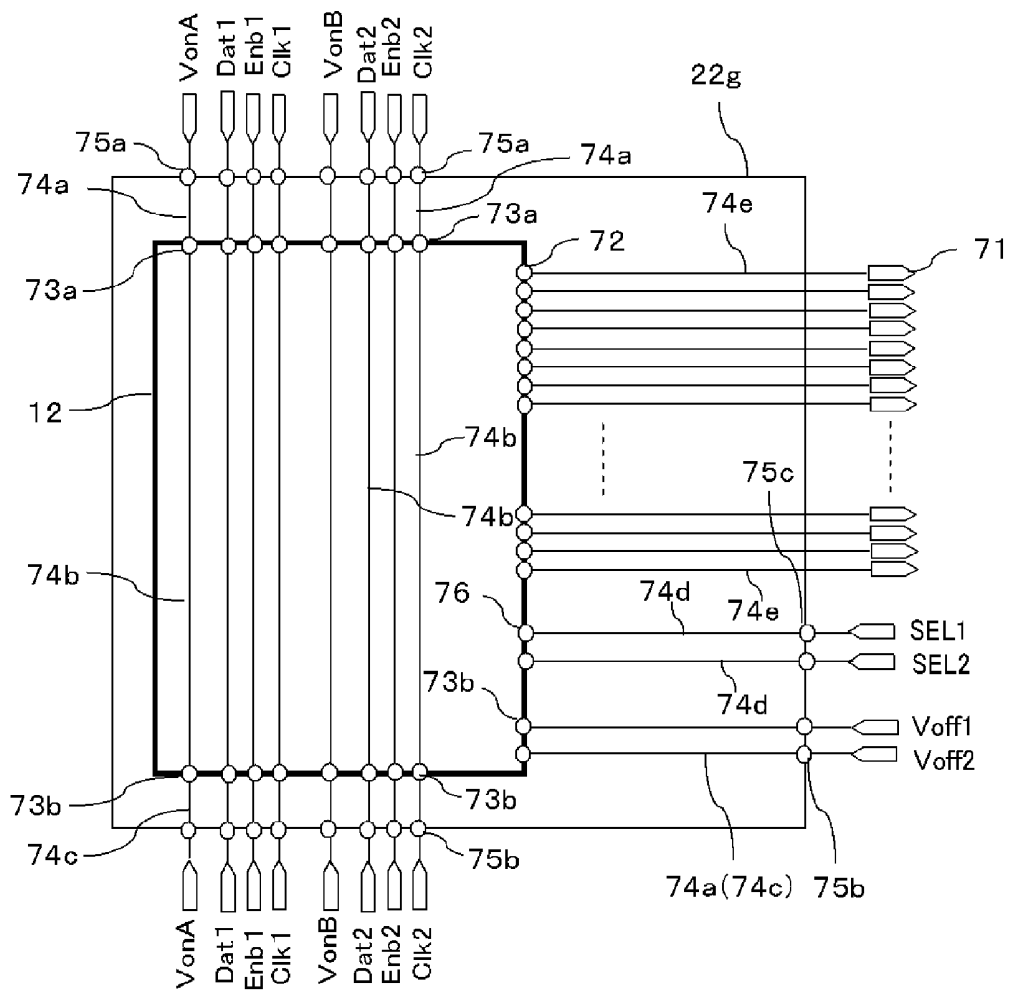

FIG. 9

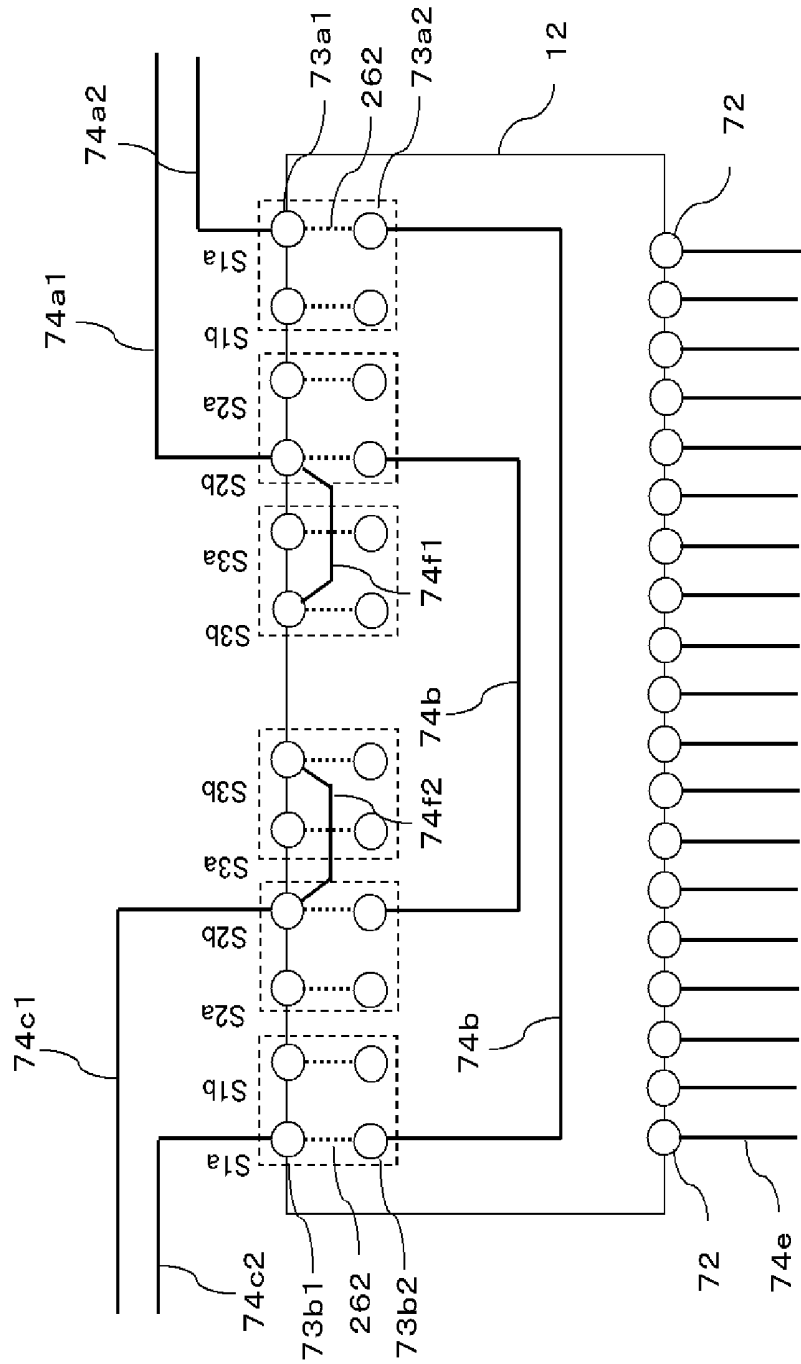

FIG. 11

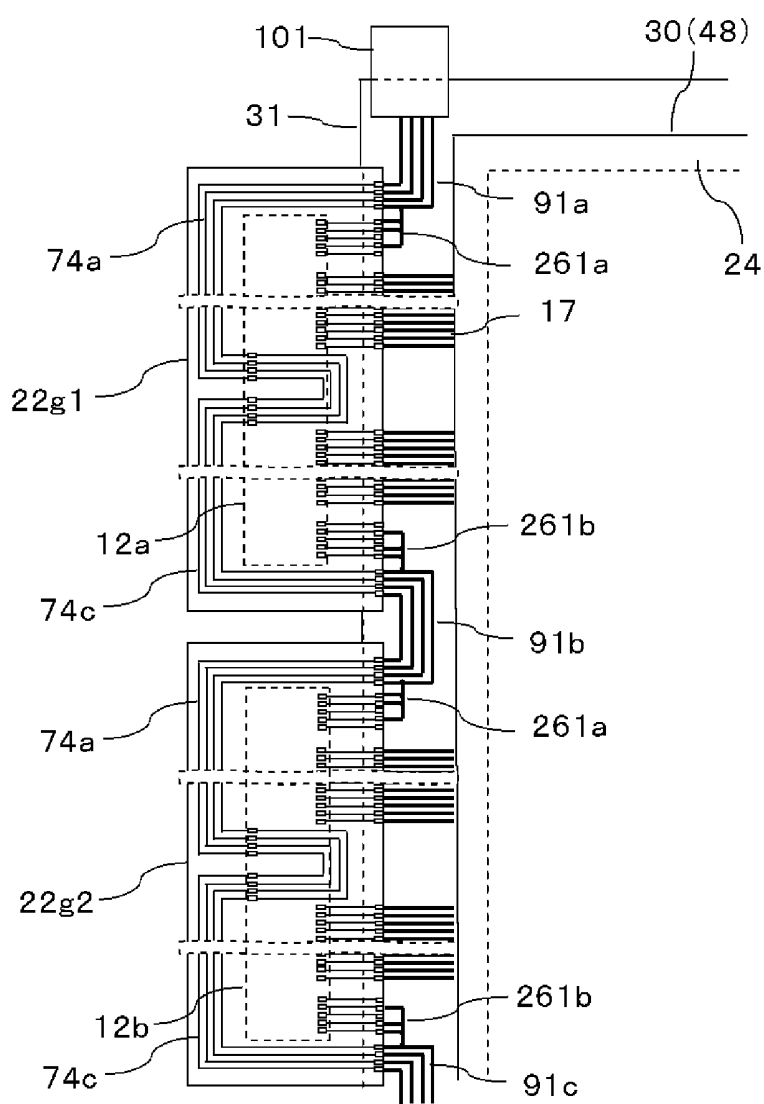

FIG. 12

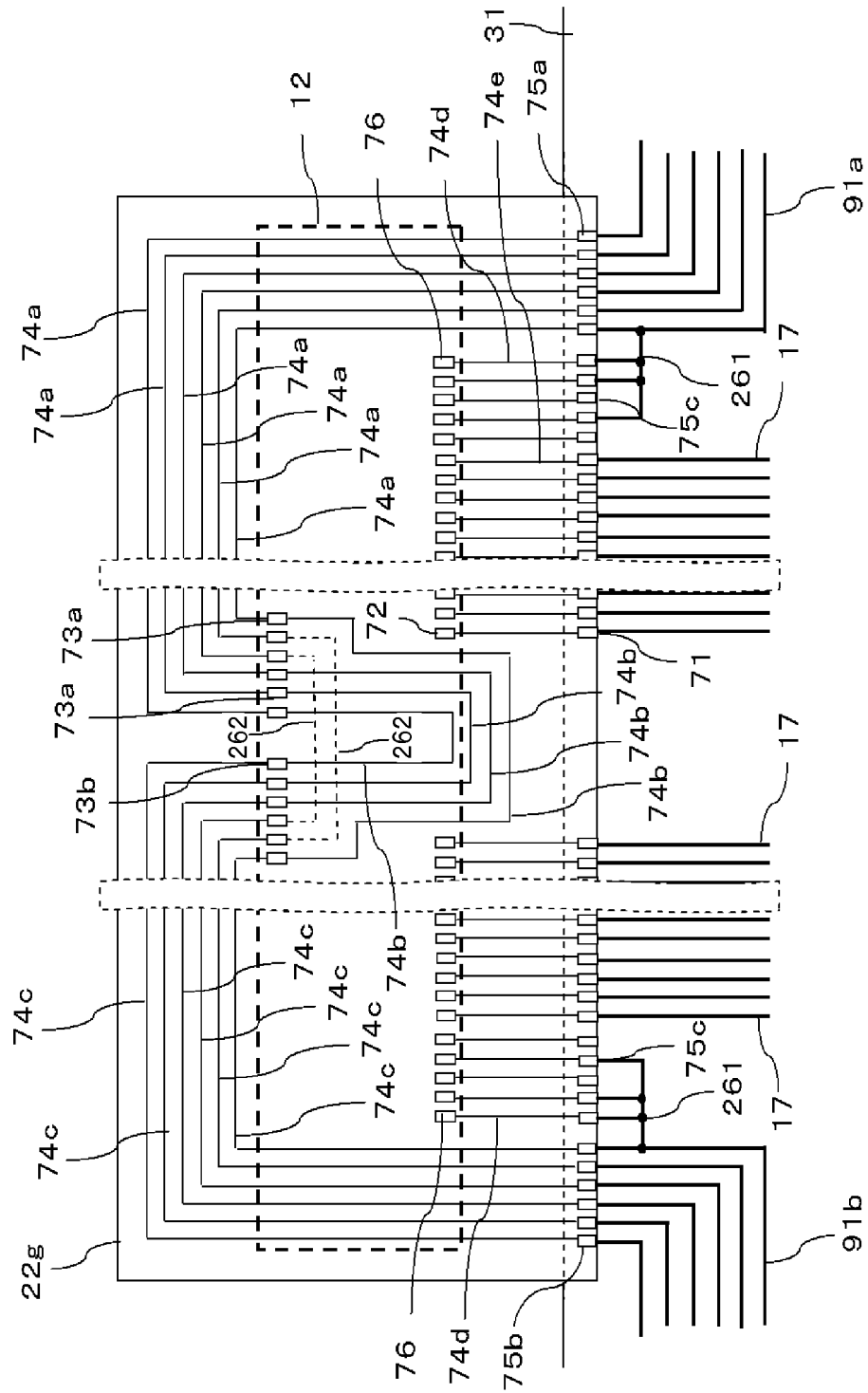

FIG. 14

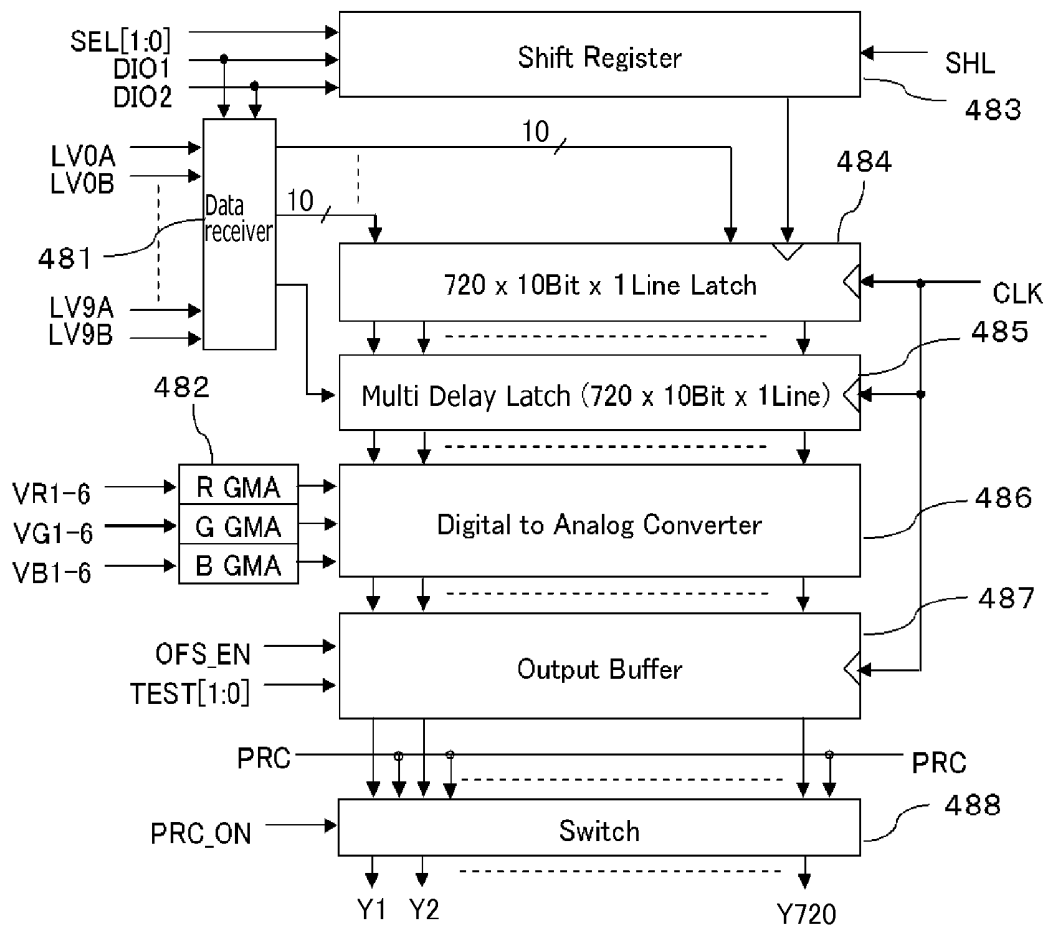

FIG. 15

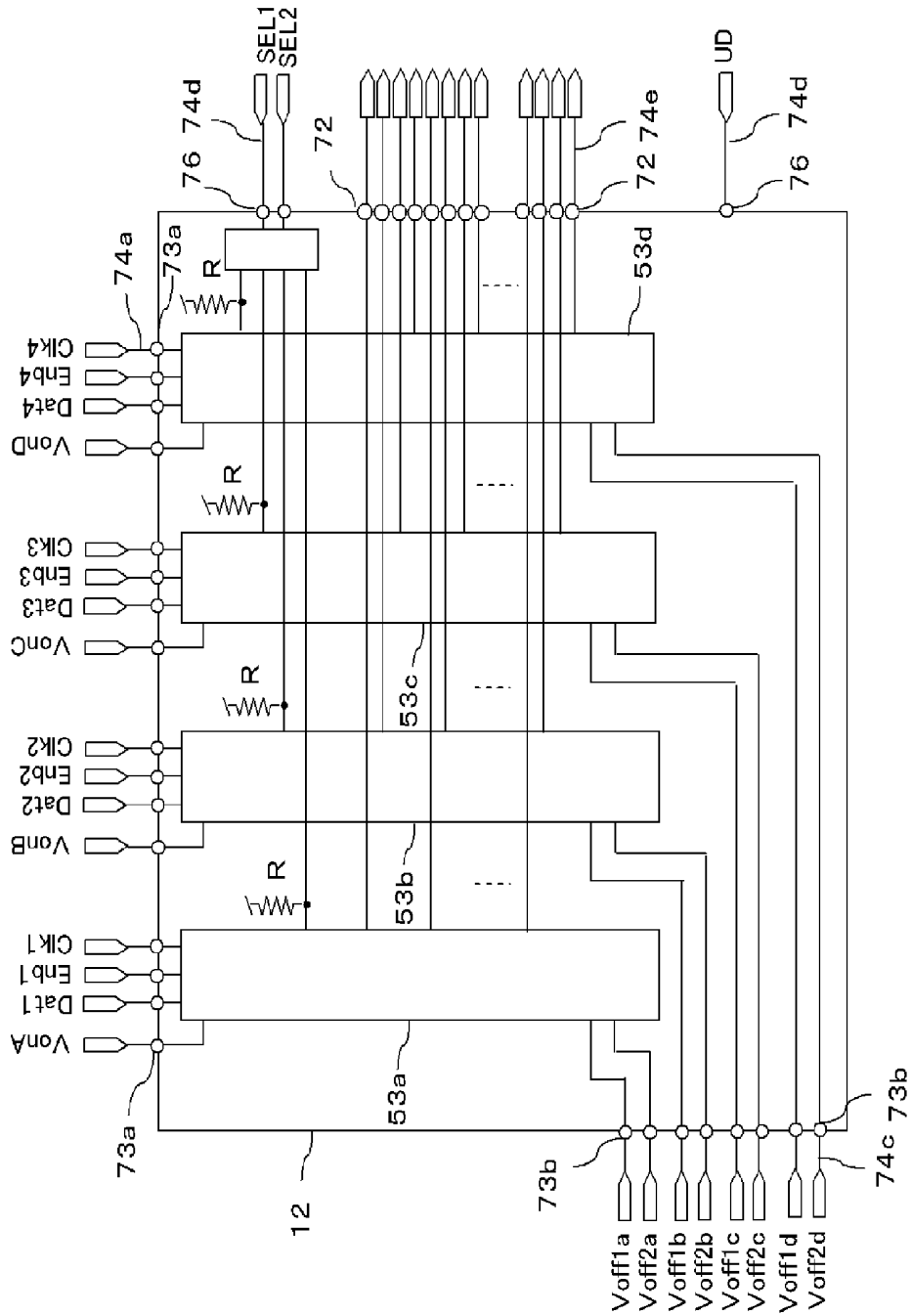

FIG. 16

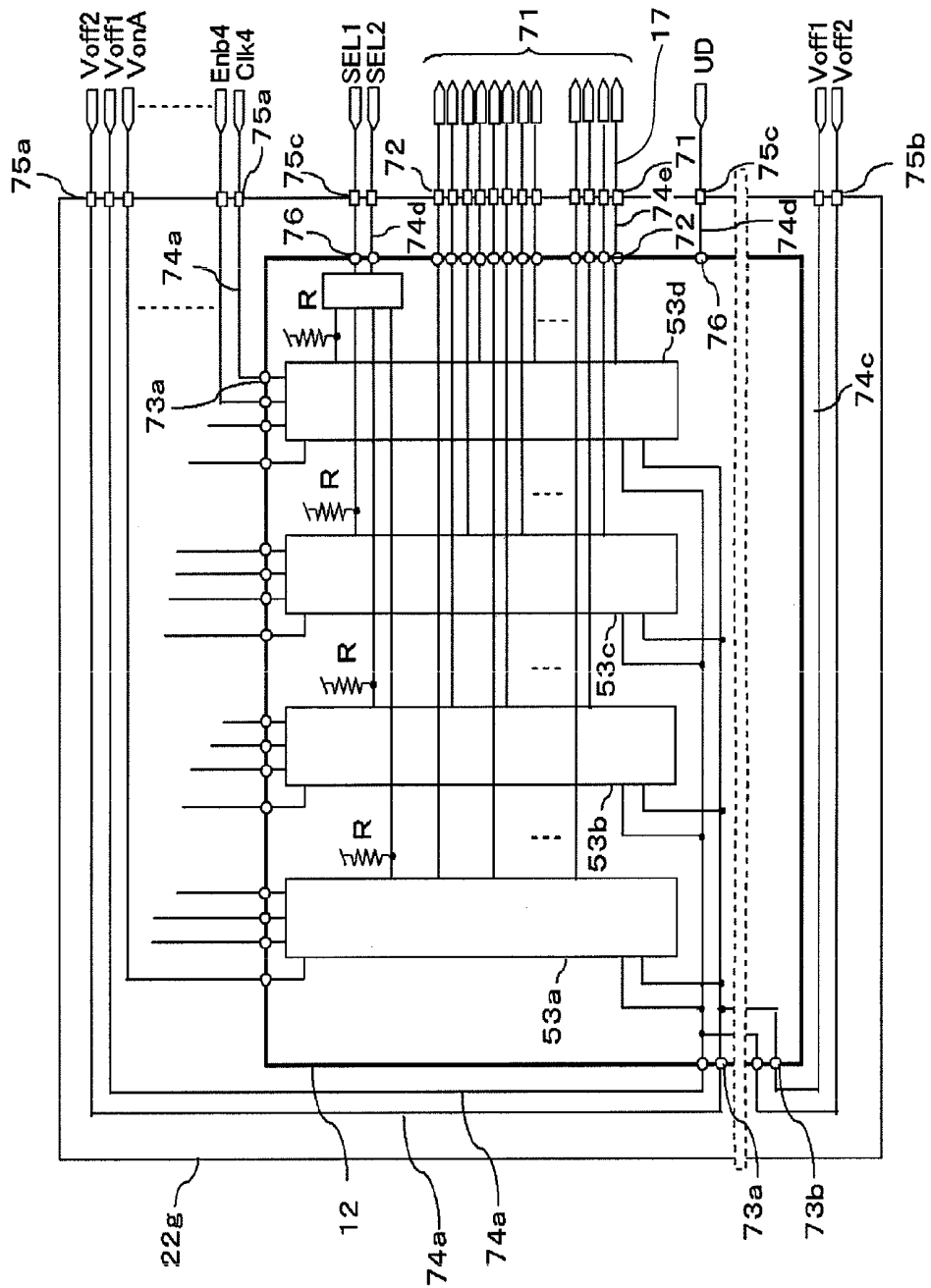

FIG. 17

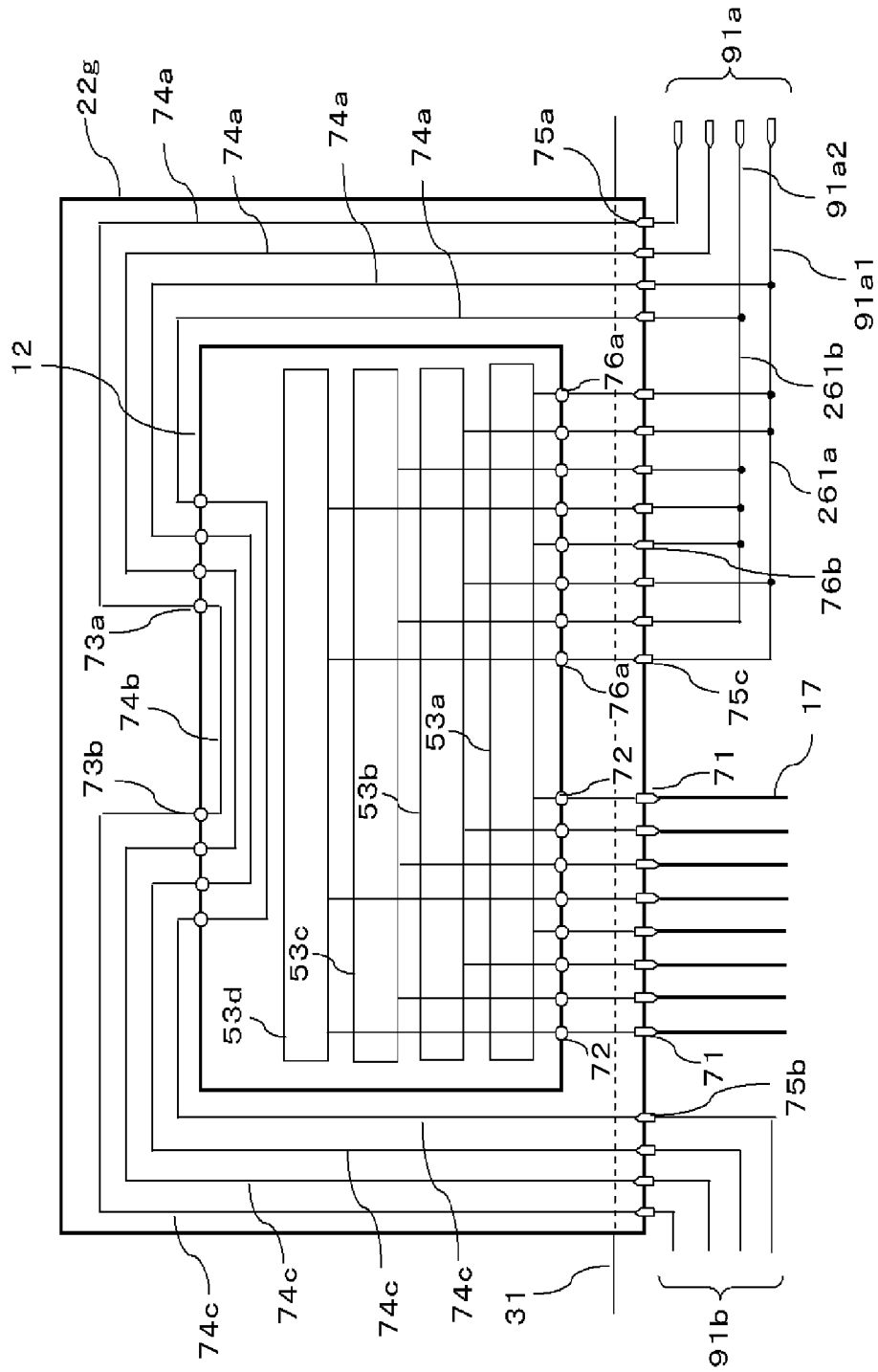

FIG. 18

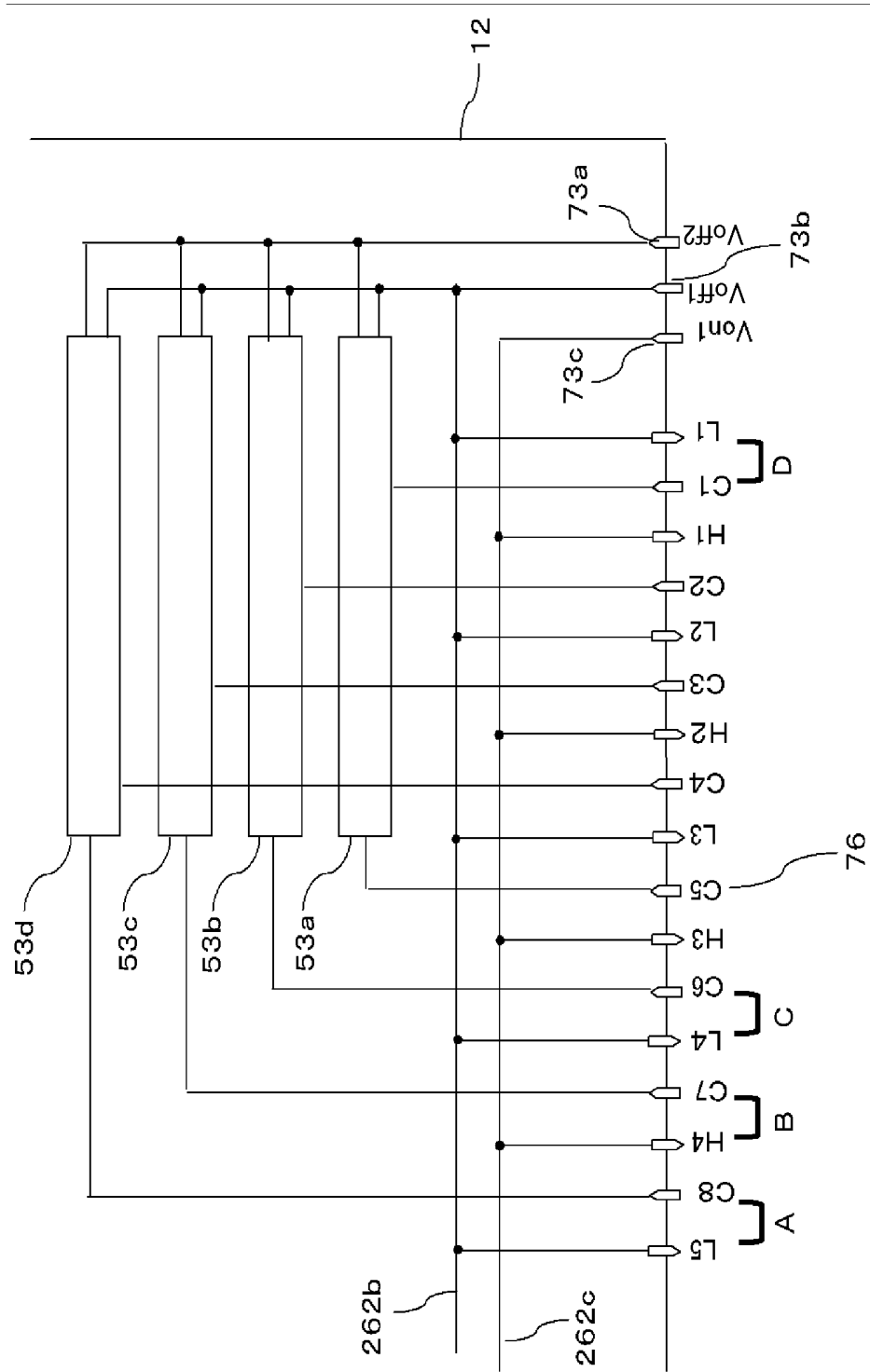

FIG. 19

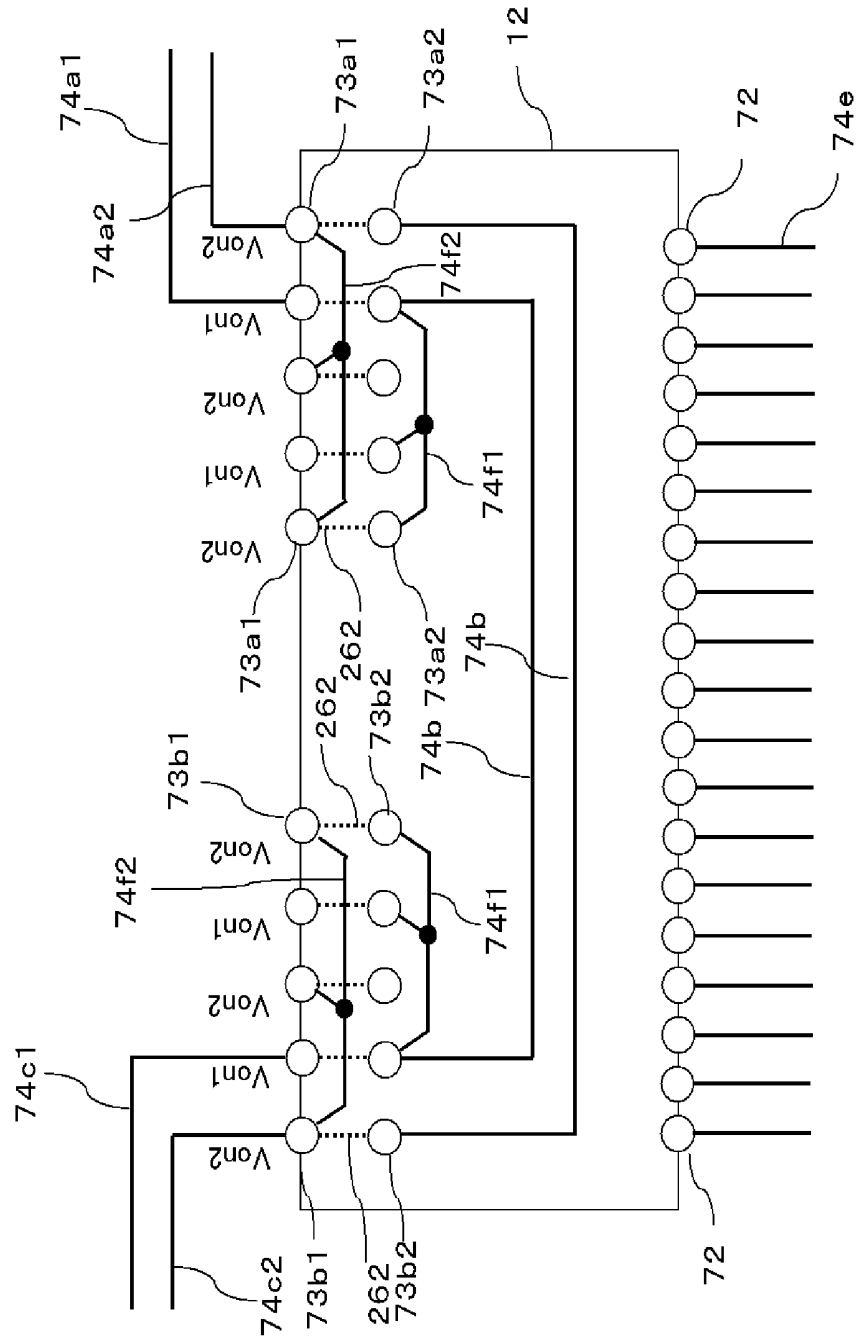

FIG. 20A

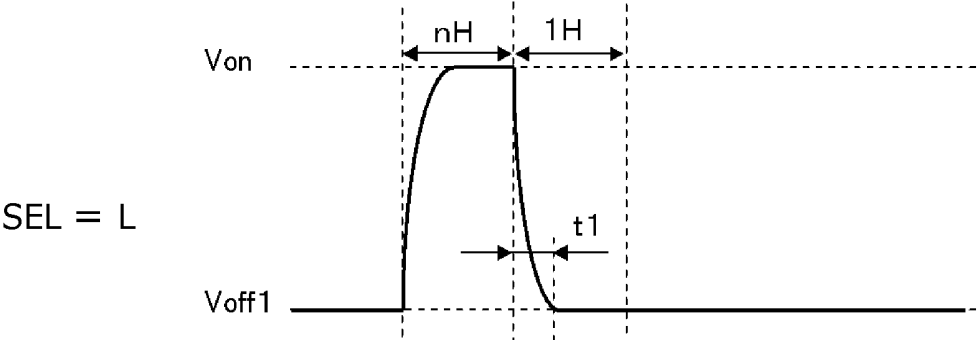

FIG. 20B

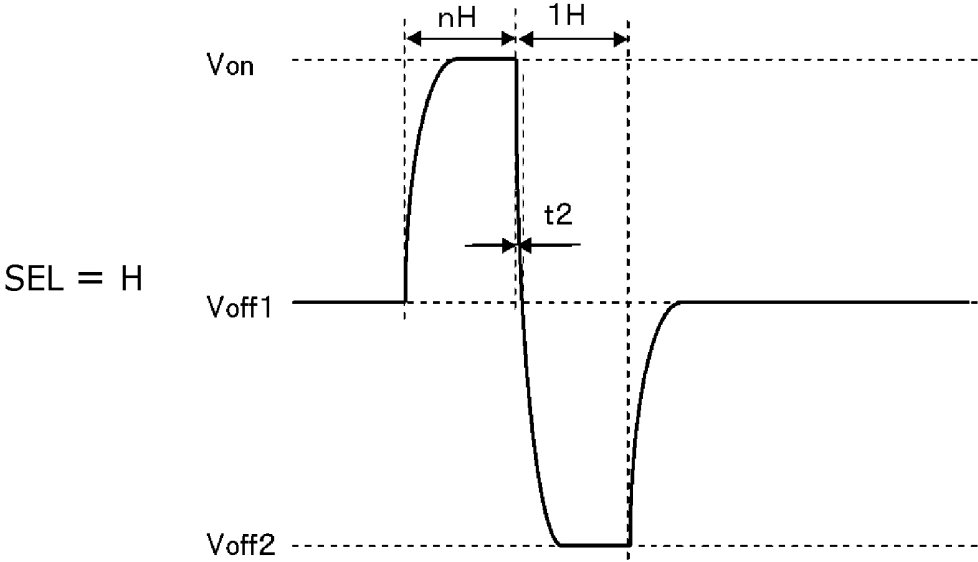

FIG. 21

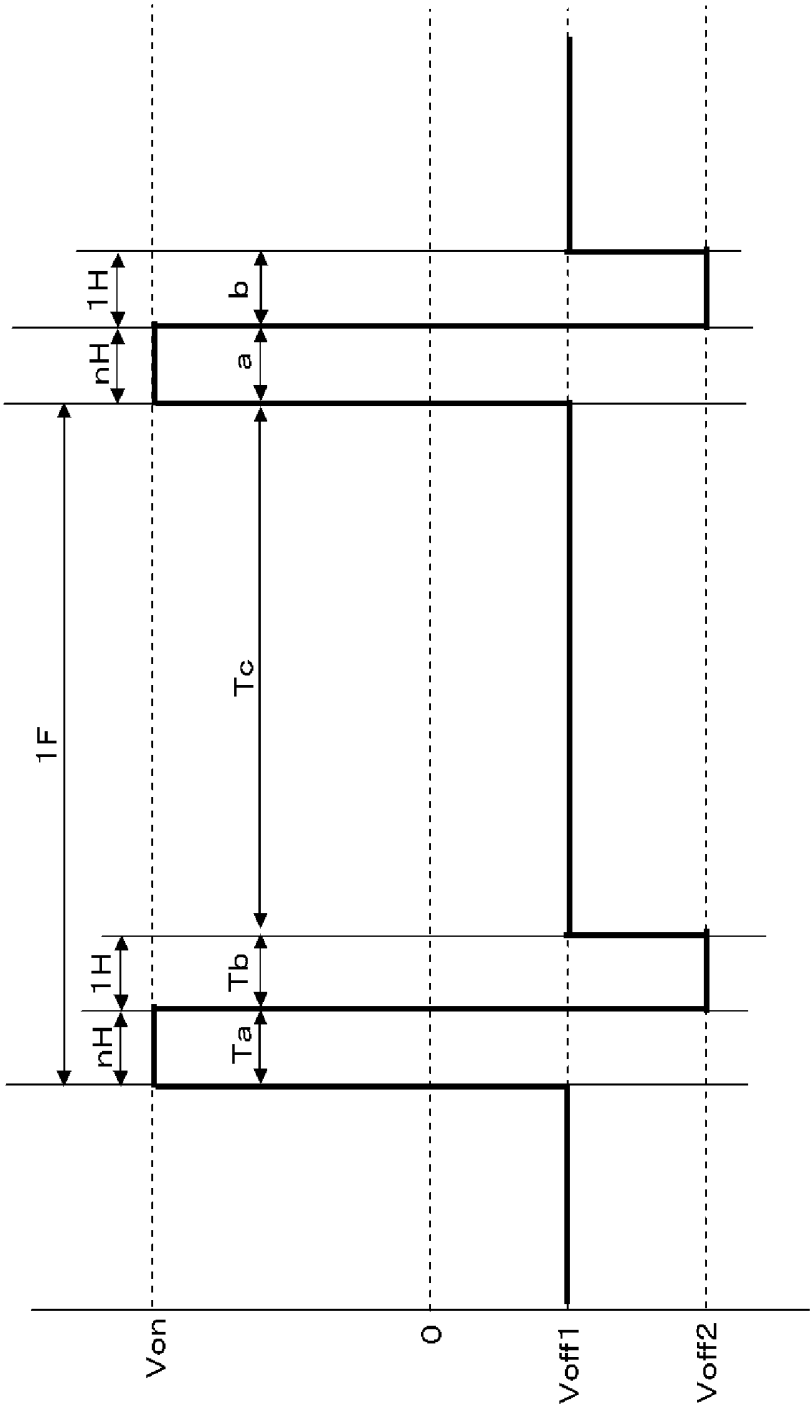

FIG. 22A

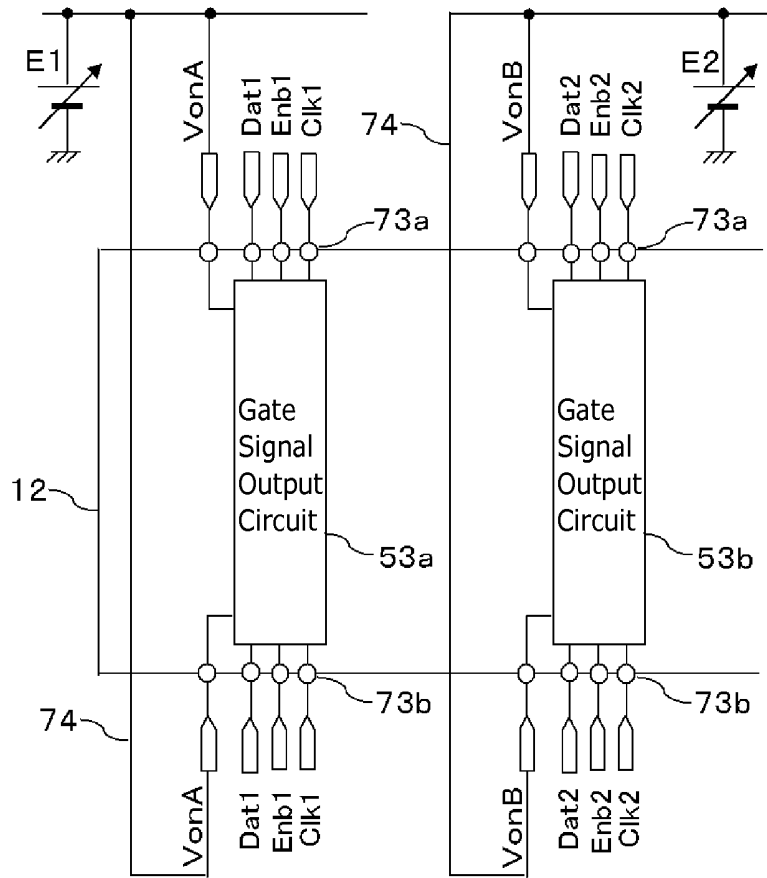

FIG. 22B

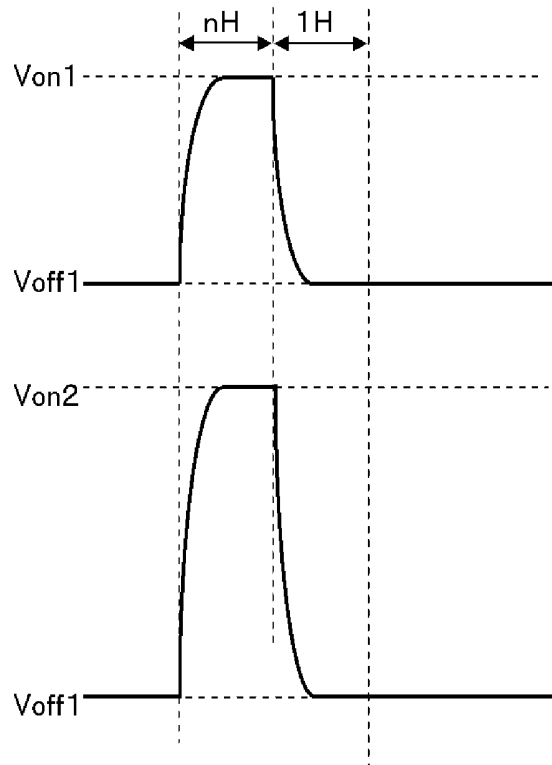

FIG. 23

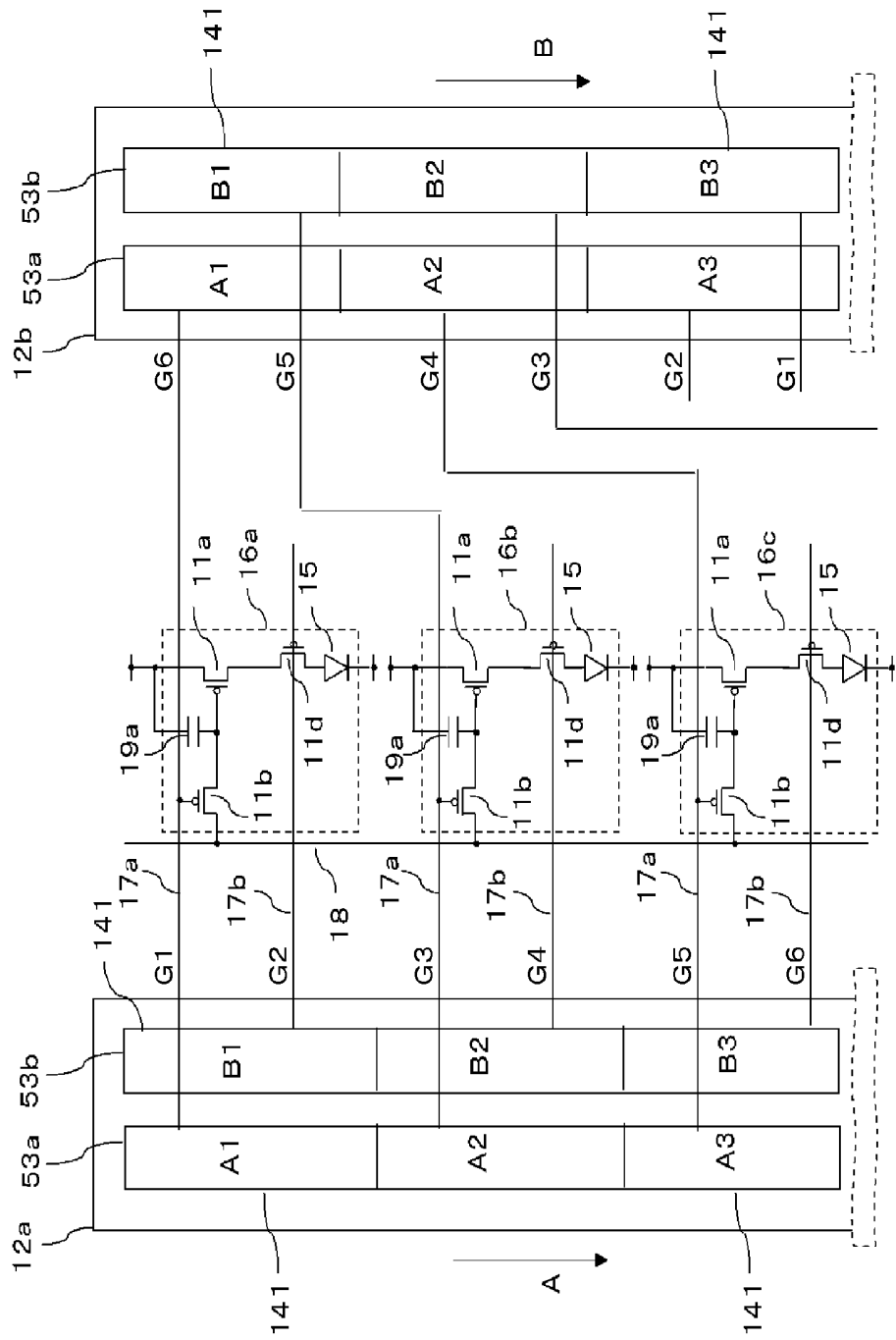

FIG. 25

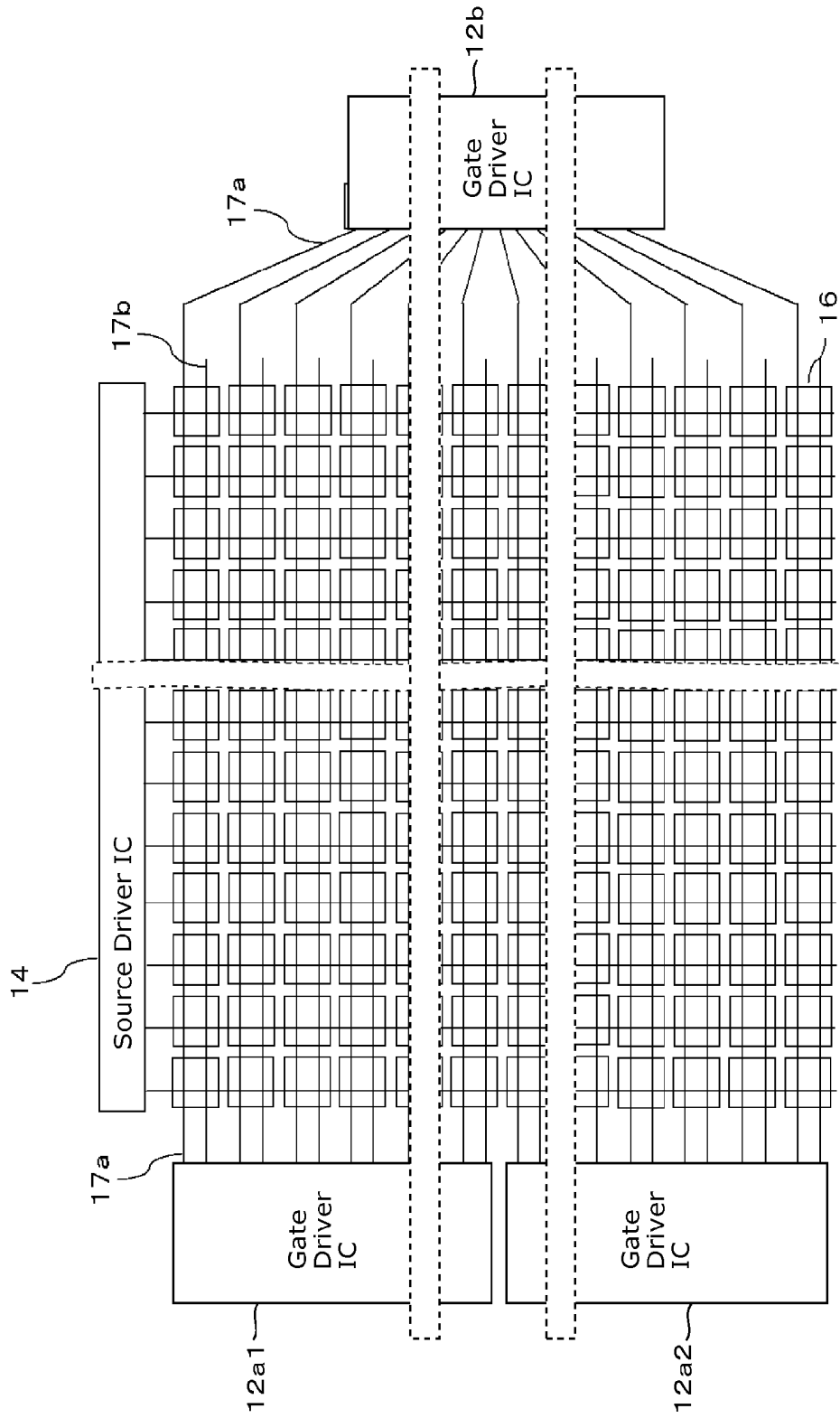

FIG. 26

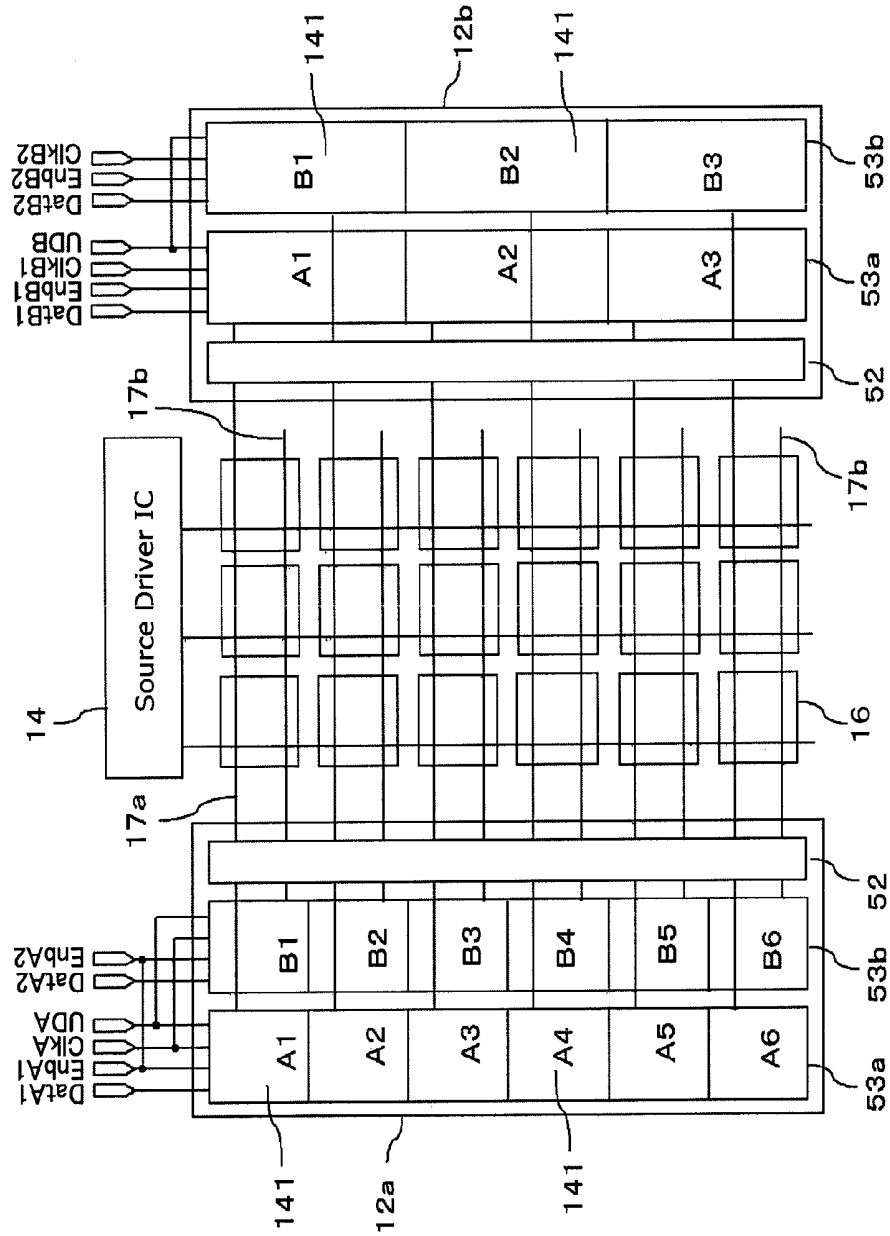

FIG. 28

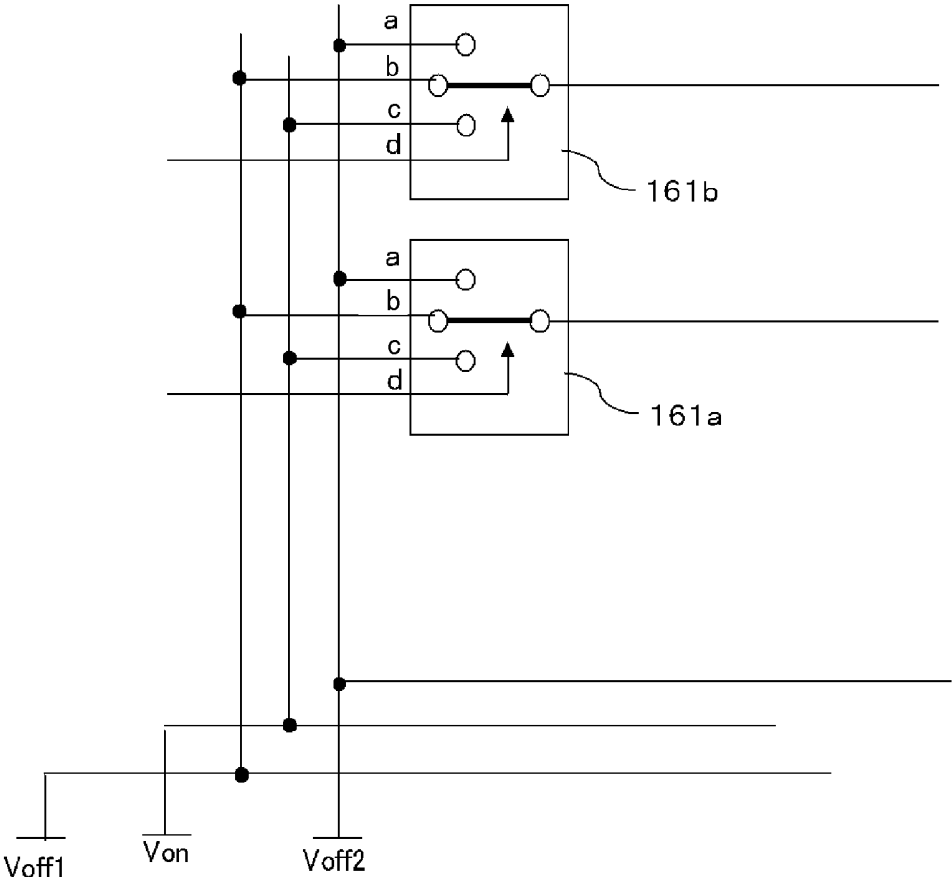

FIG. 29

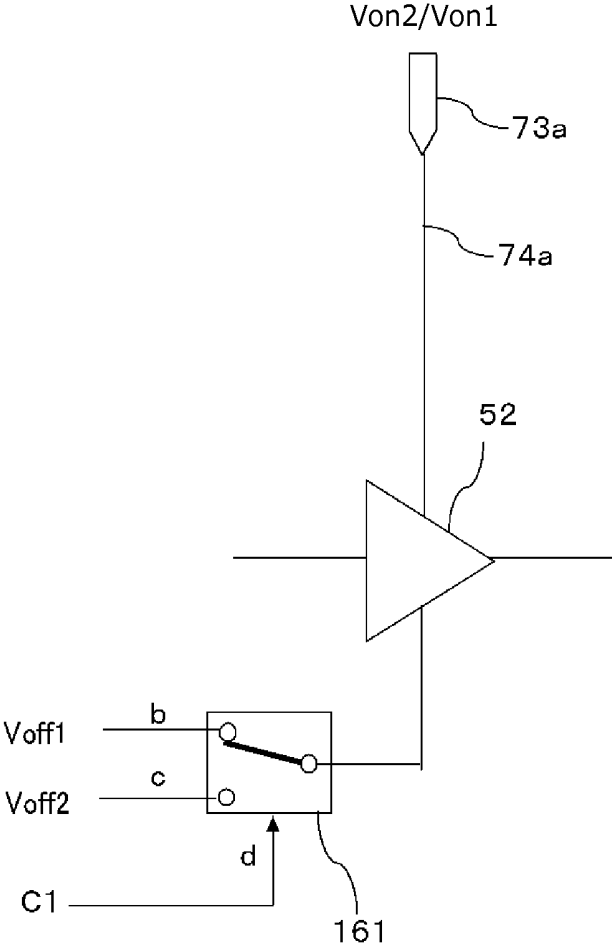

FIG. 30A

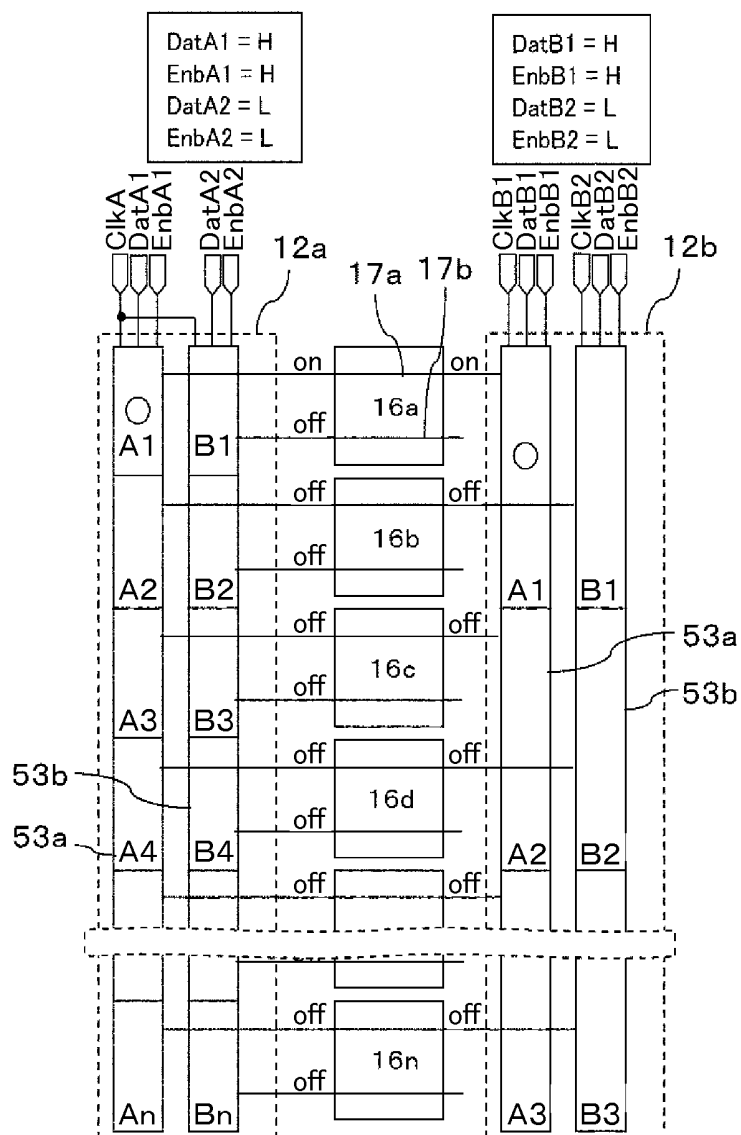

FIG. 30B

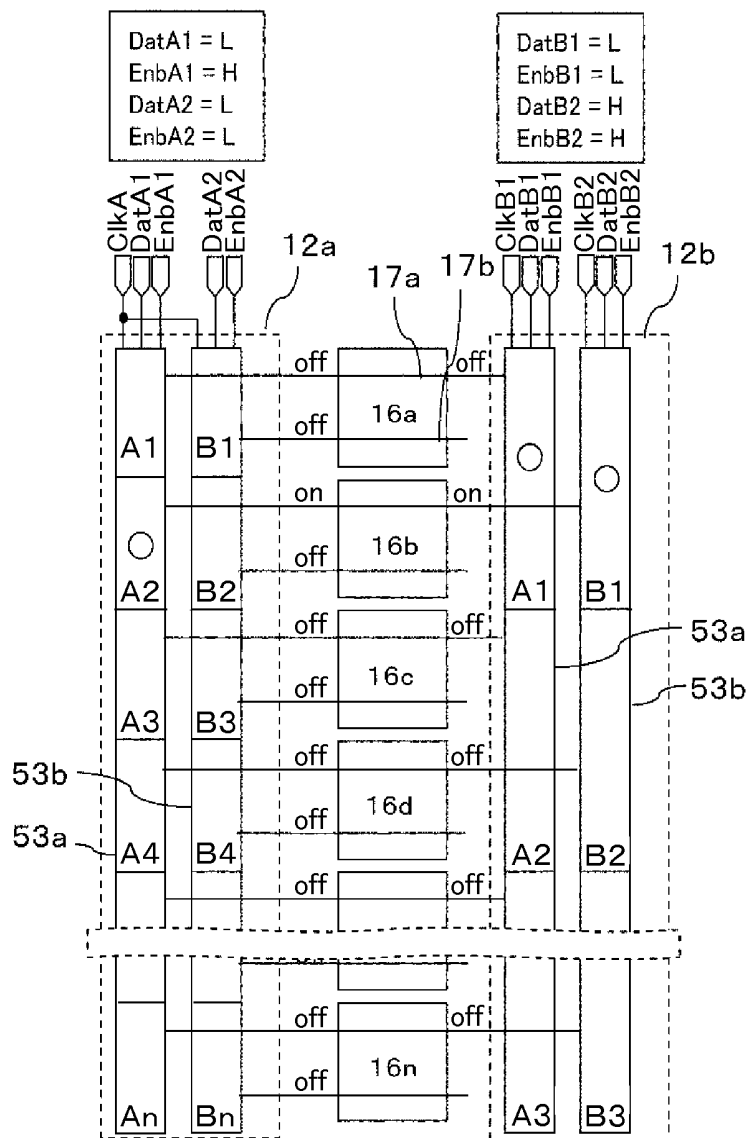

FIG. 31A

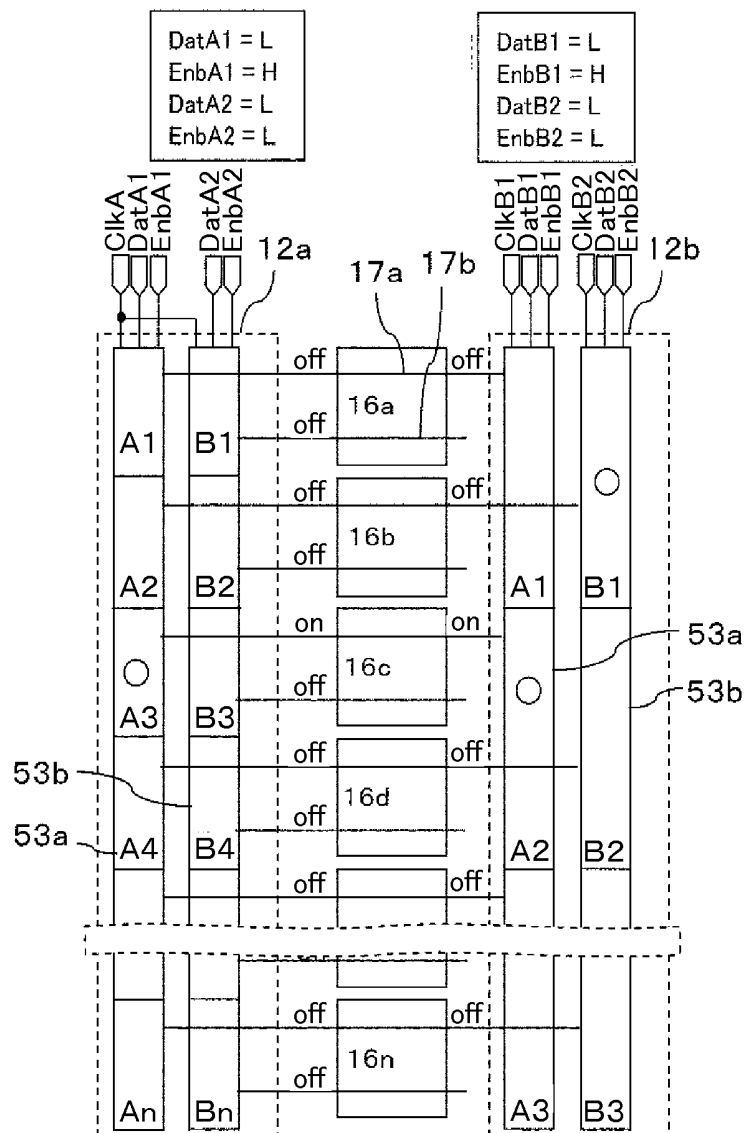

FIG. 31B

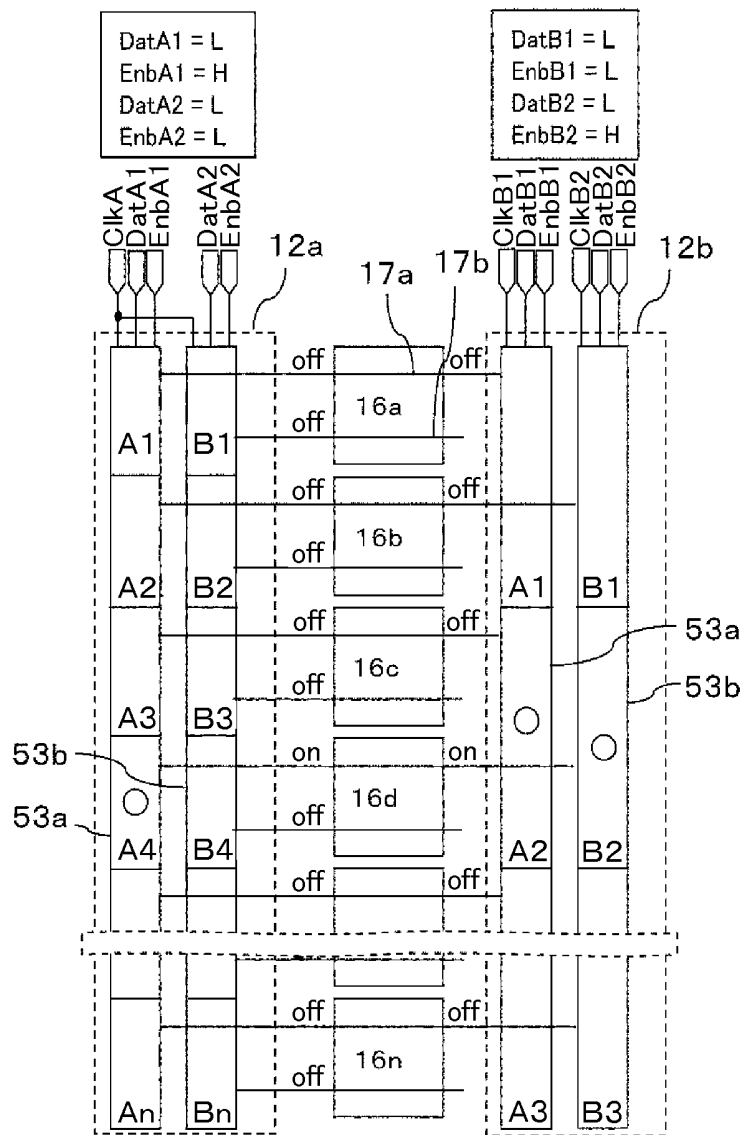

FIG. 32A

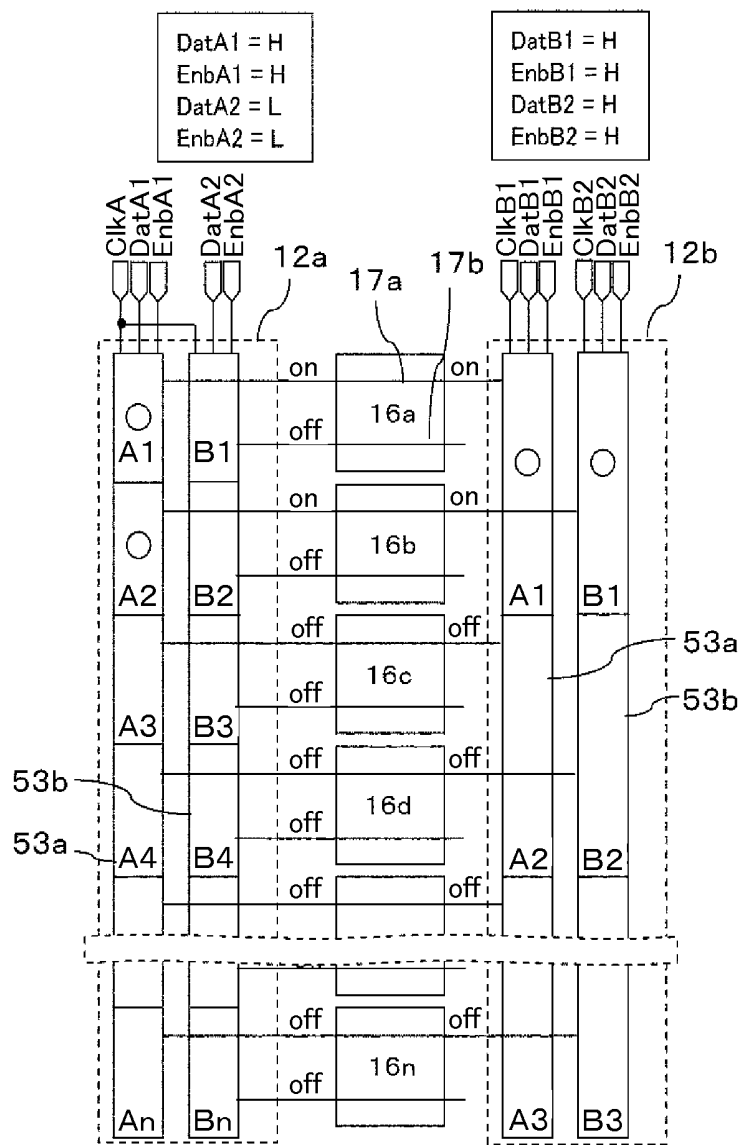

FIG. 32B

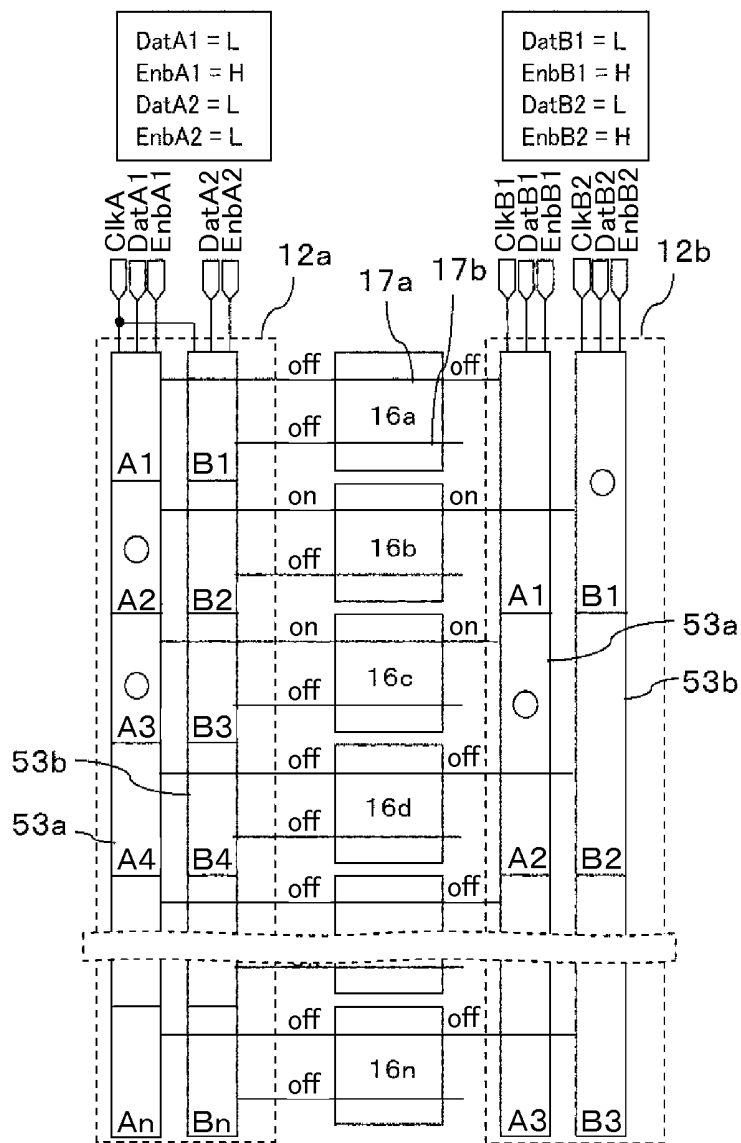

FIG. 33A

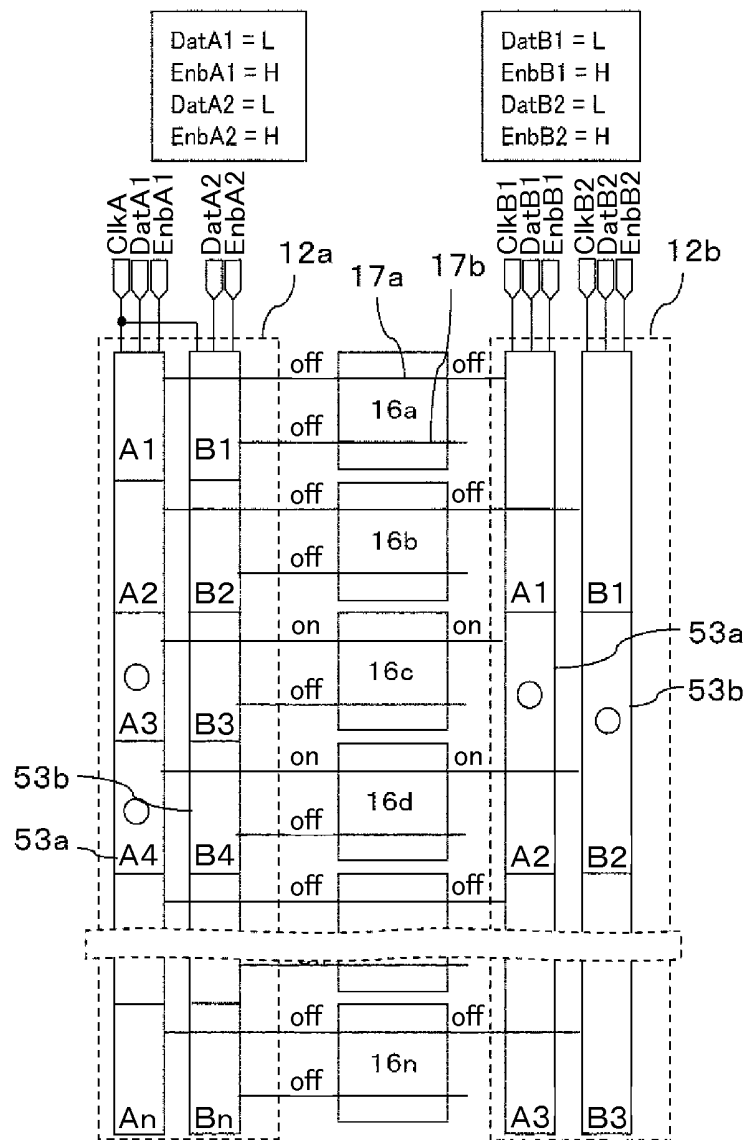

FIG. 33B

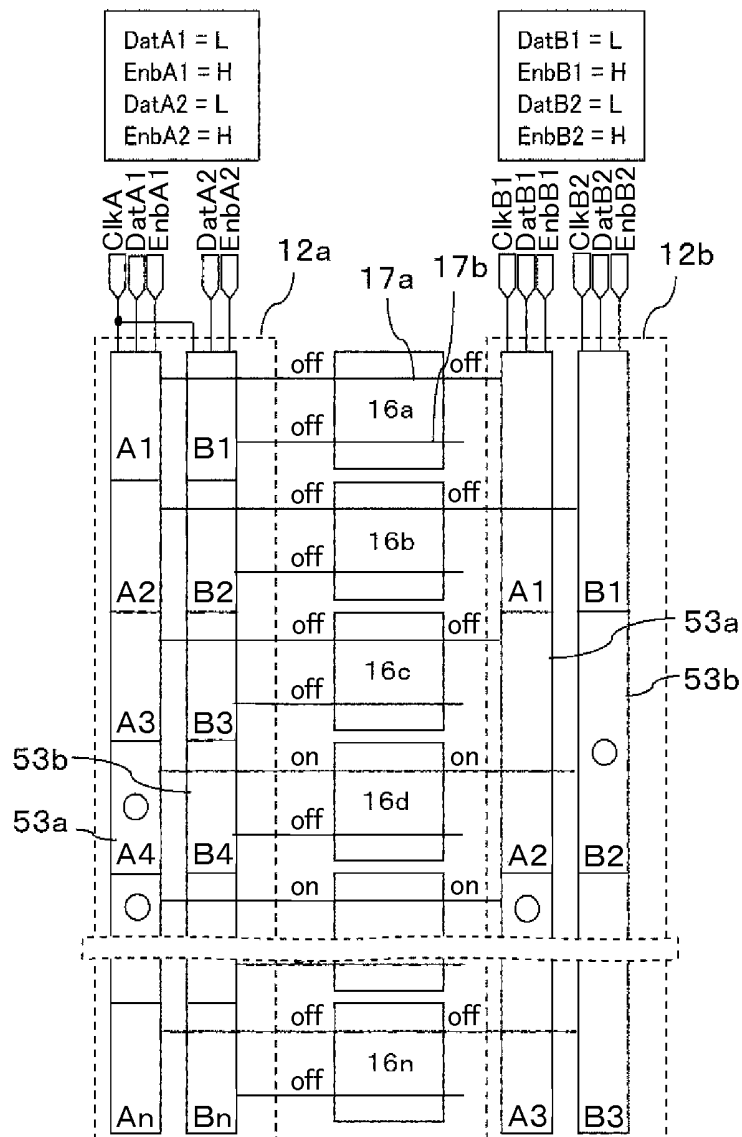

FIG. 34A

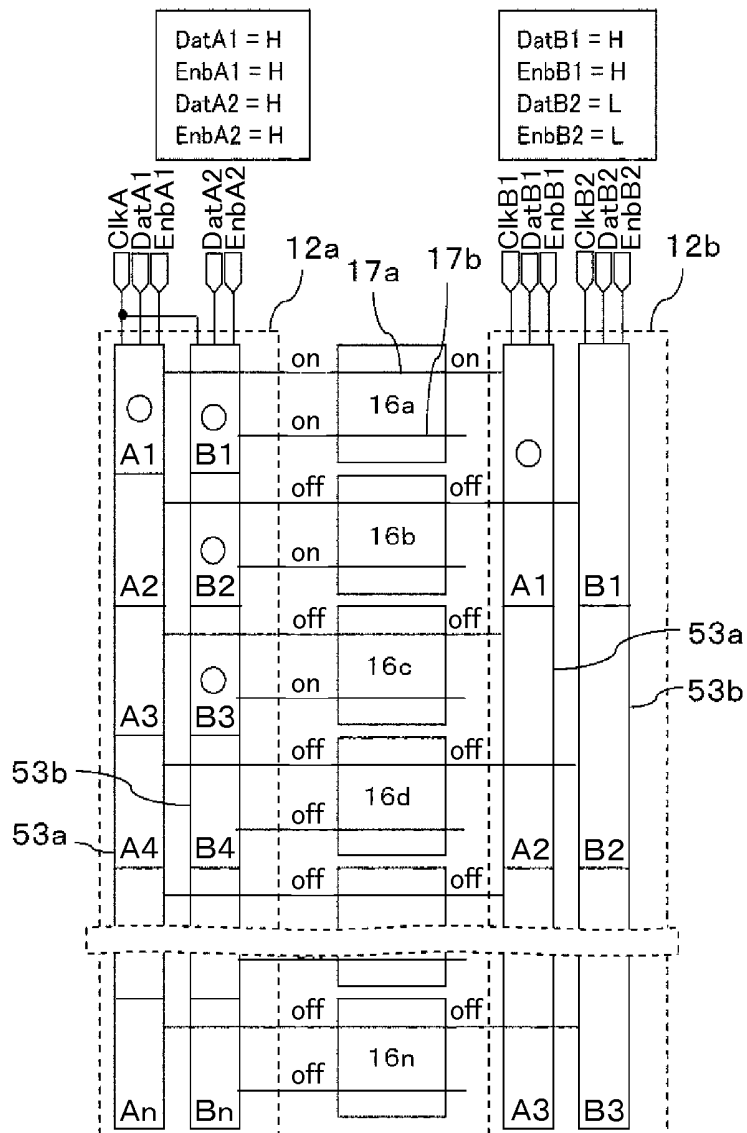

FIG. 34B

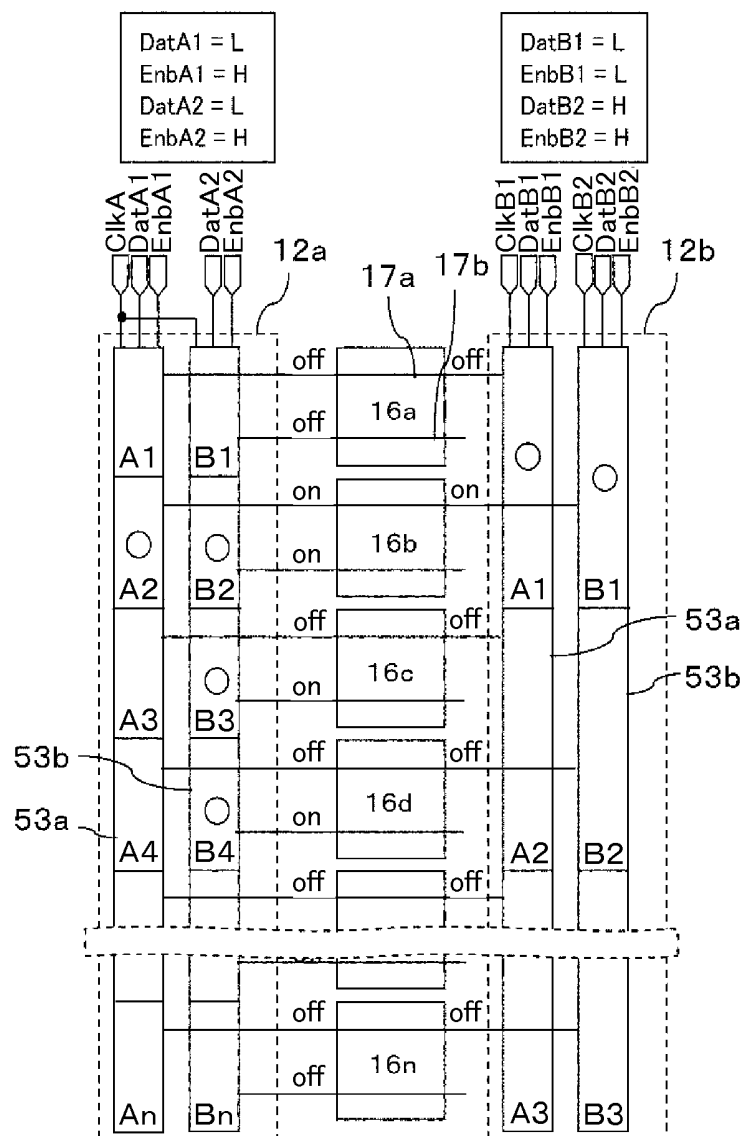

FIG. 35

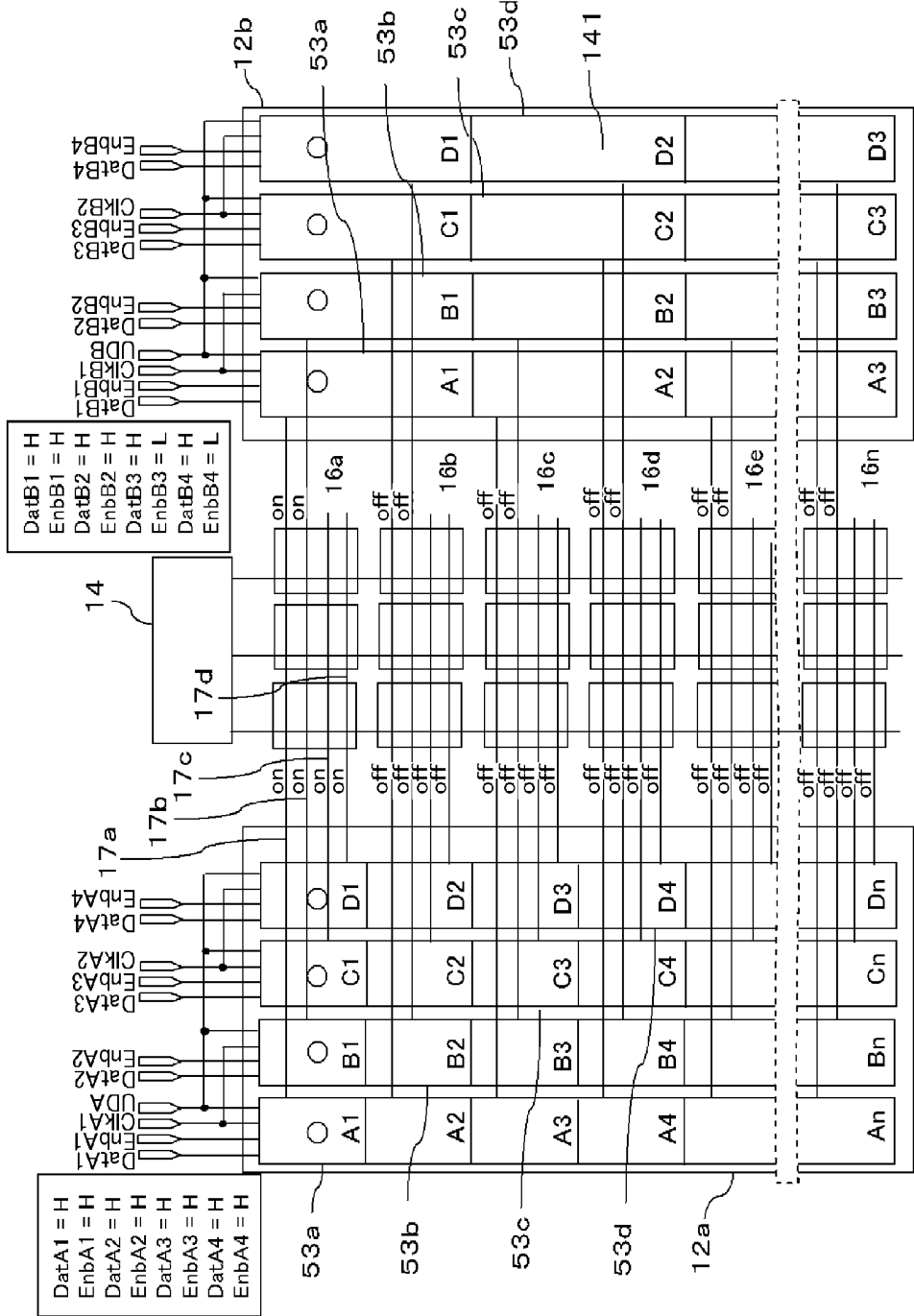

FIG. 36

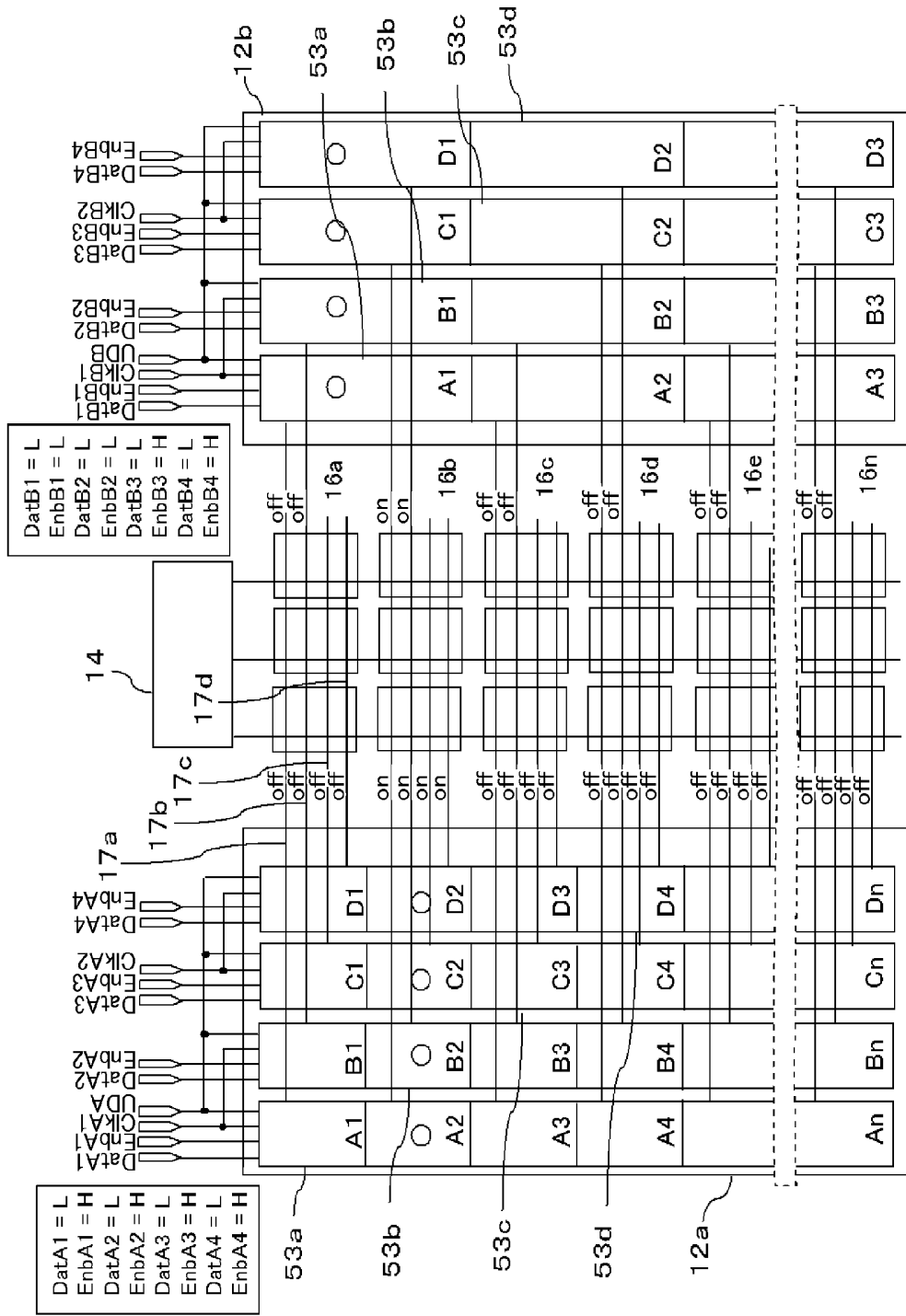

FIG. 37

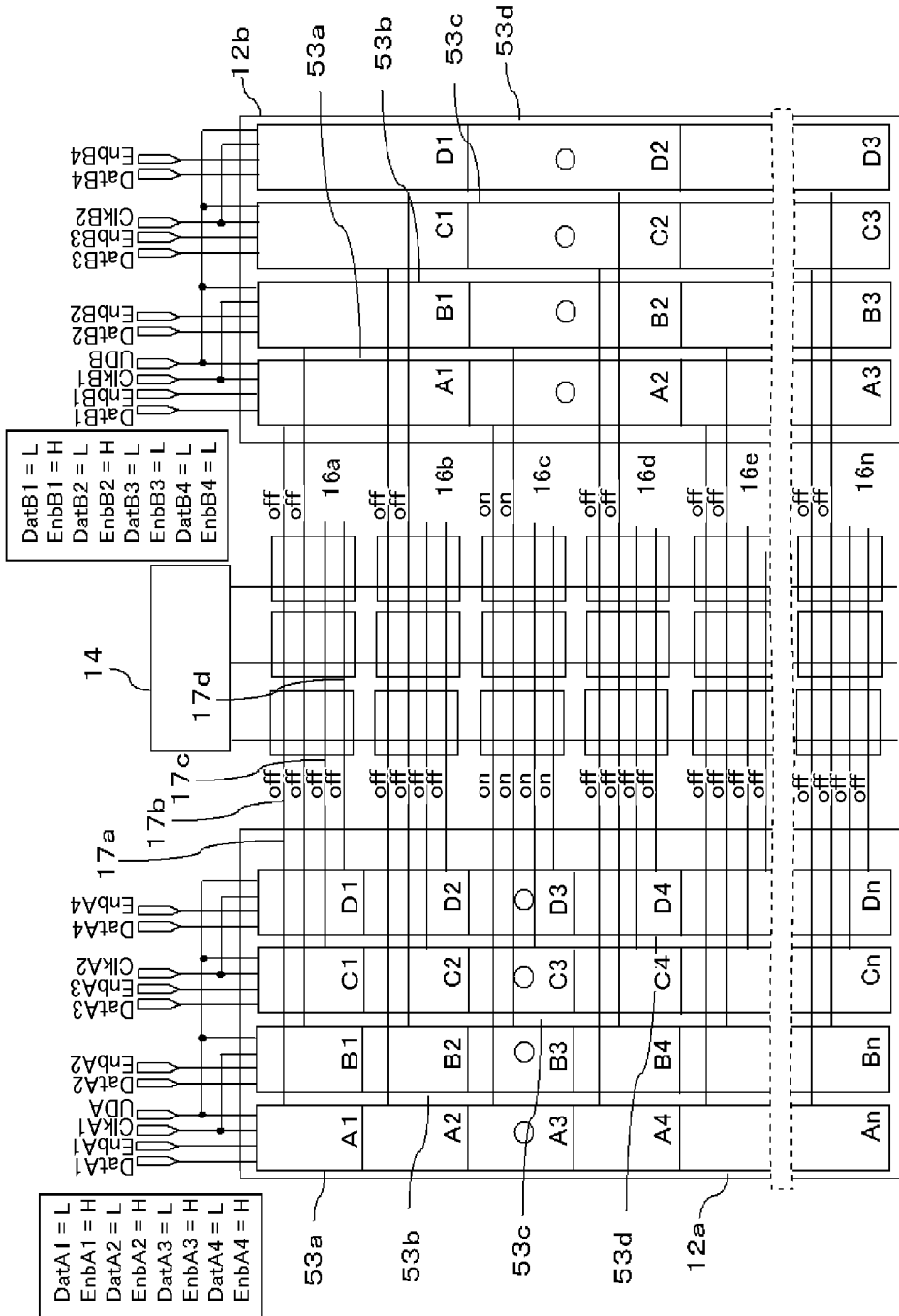

FIG. 38

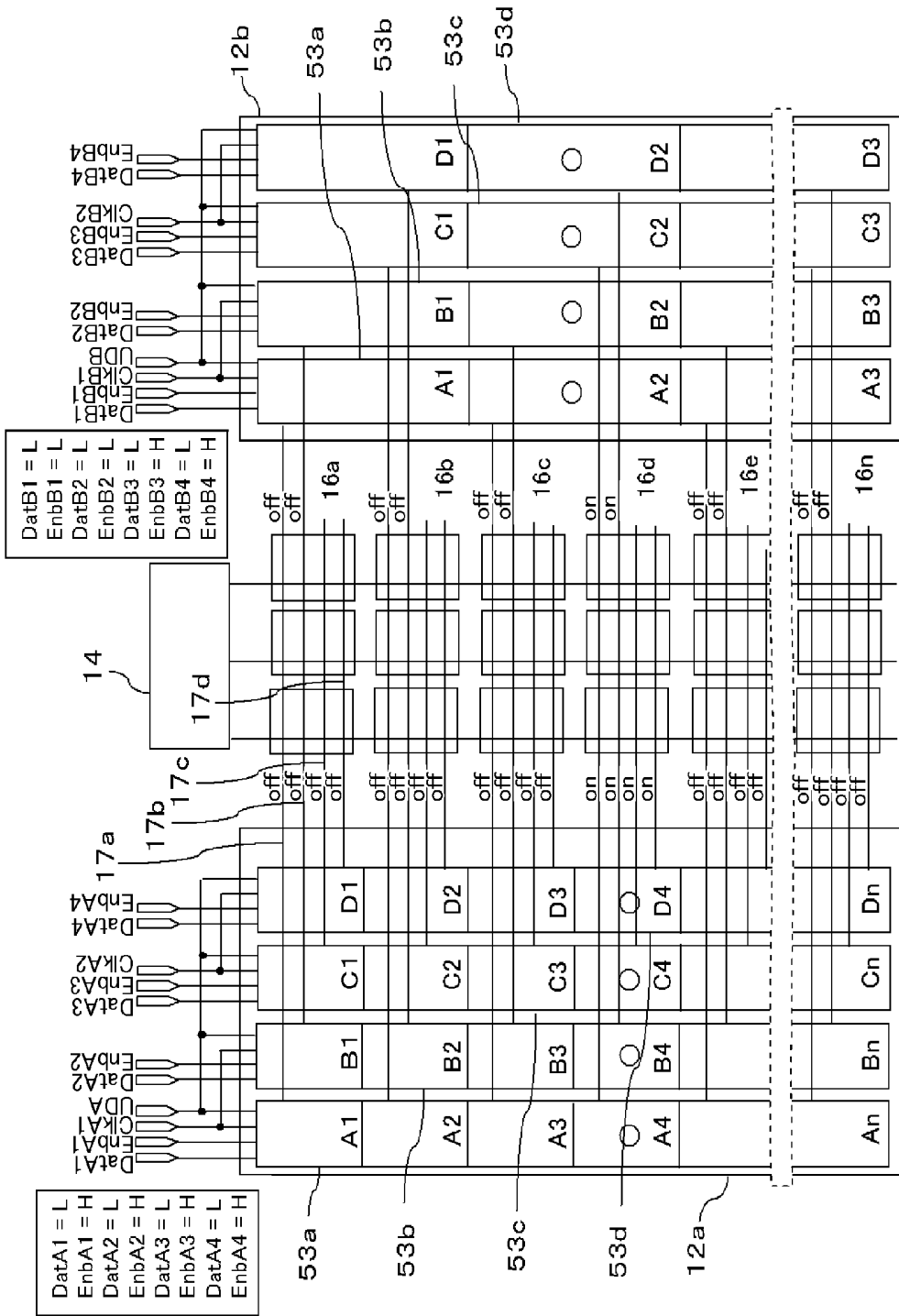

FIG. 39

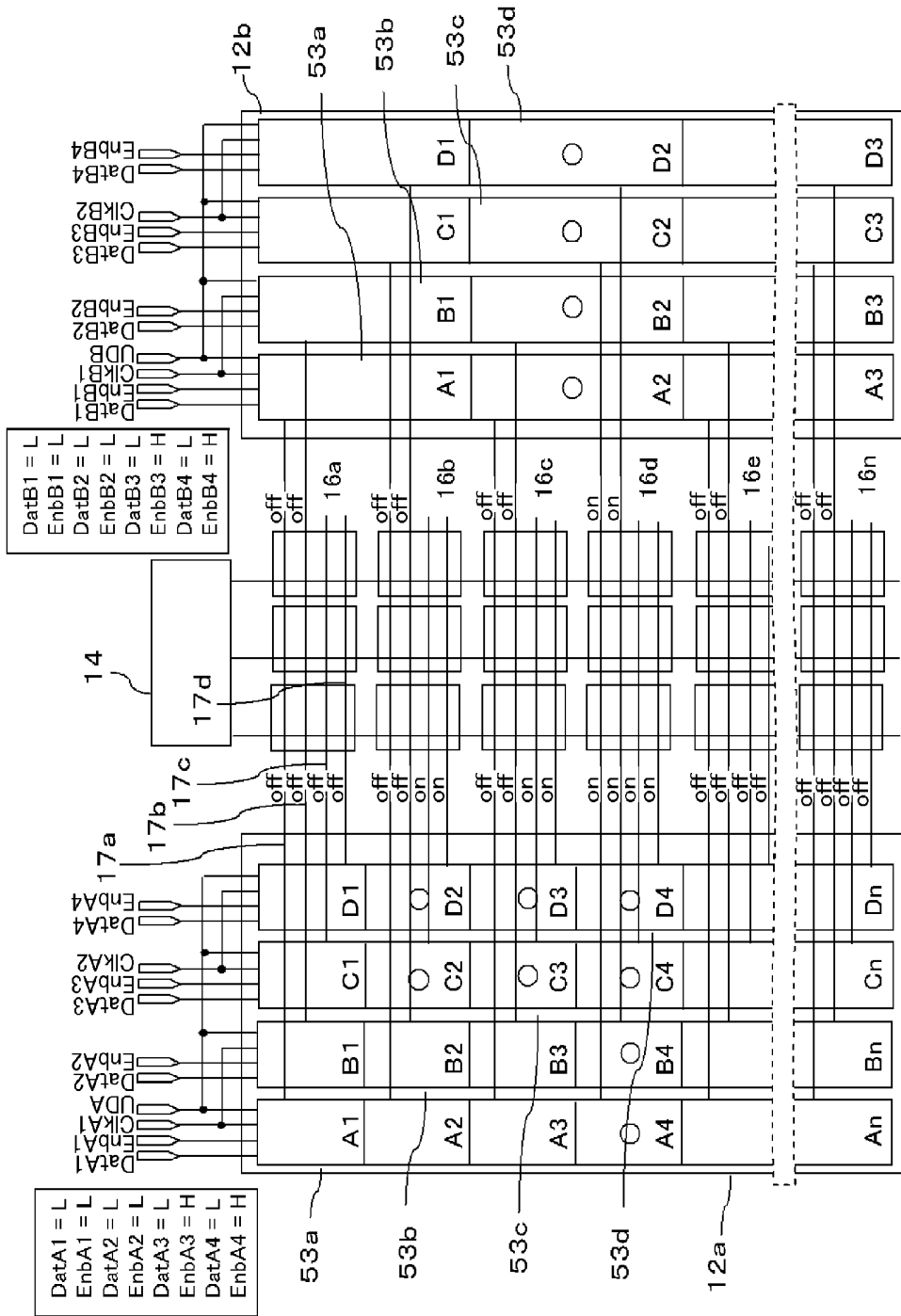

FIG. 40

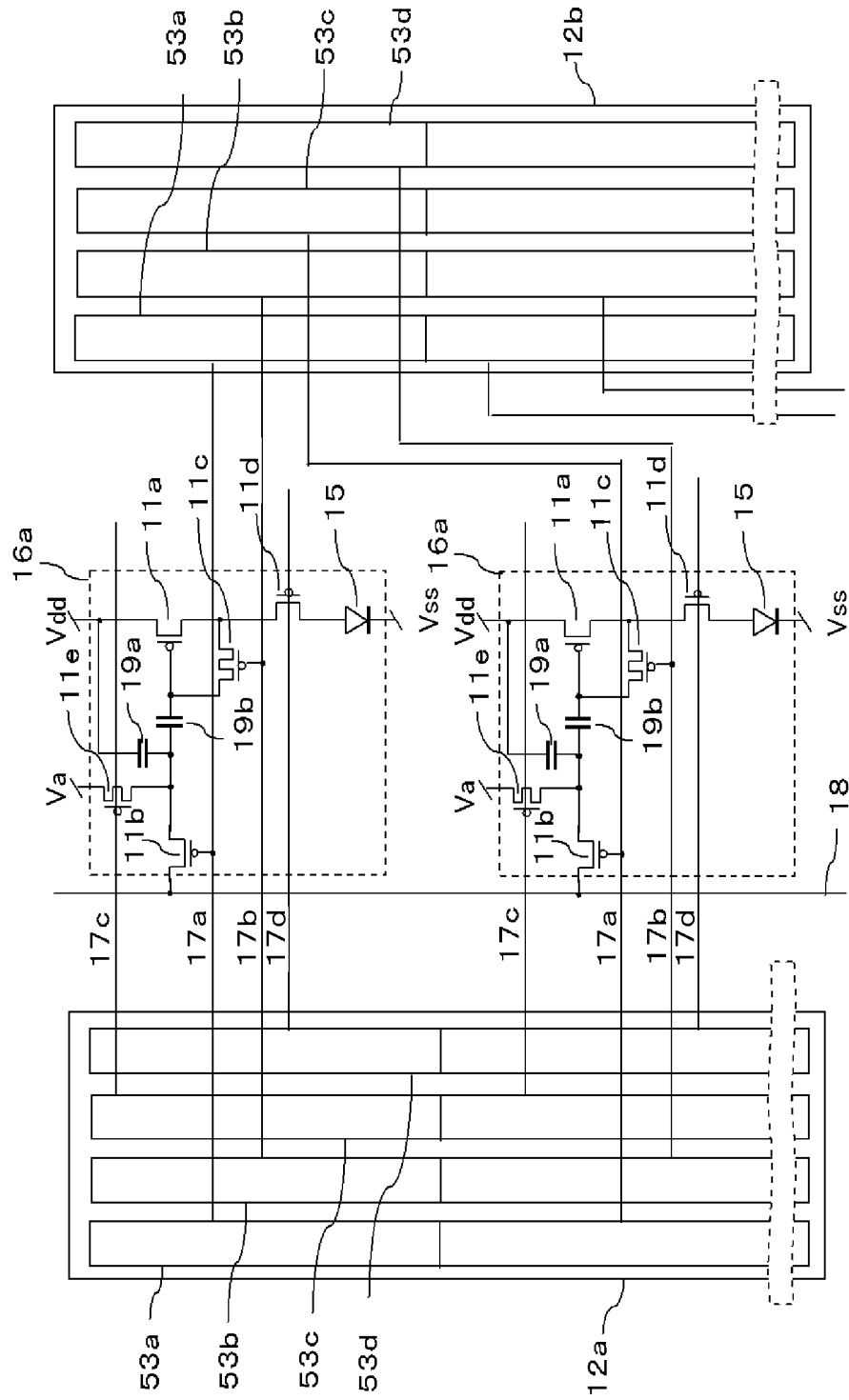
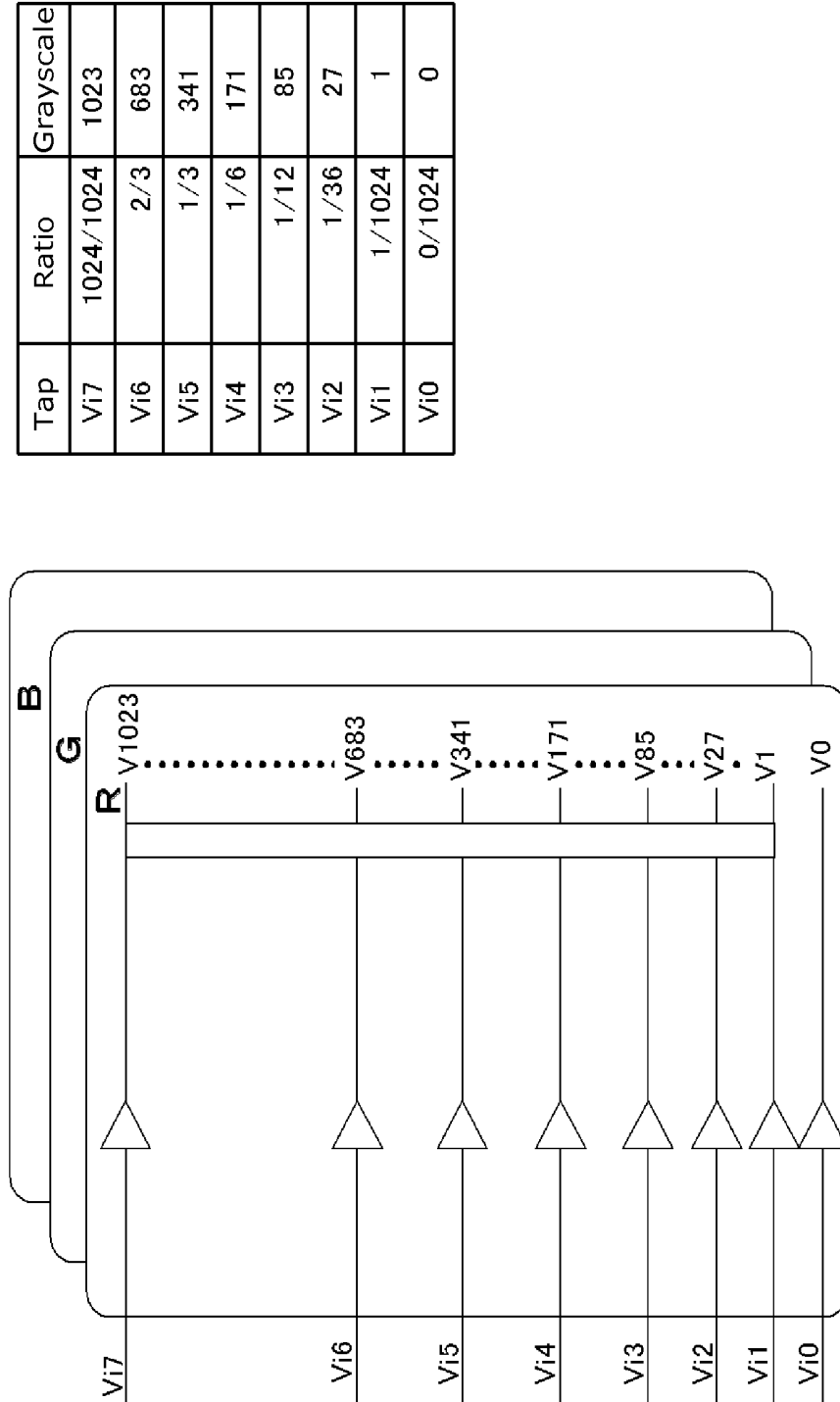

FIG. 41



Tap	Ratio	Grayscale
Vi7	1024/1024	1023
Vi6	2/3	683
Vi5	1/3	341
Vi4	1/6	171
Vi3	1/12	85
Vi2	1/36	27
Vi1	1/1024	1
Vi0	0/1024	0

FIG. 42

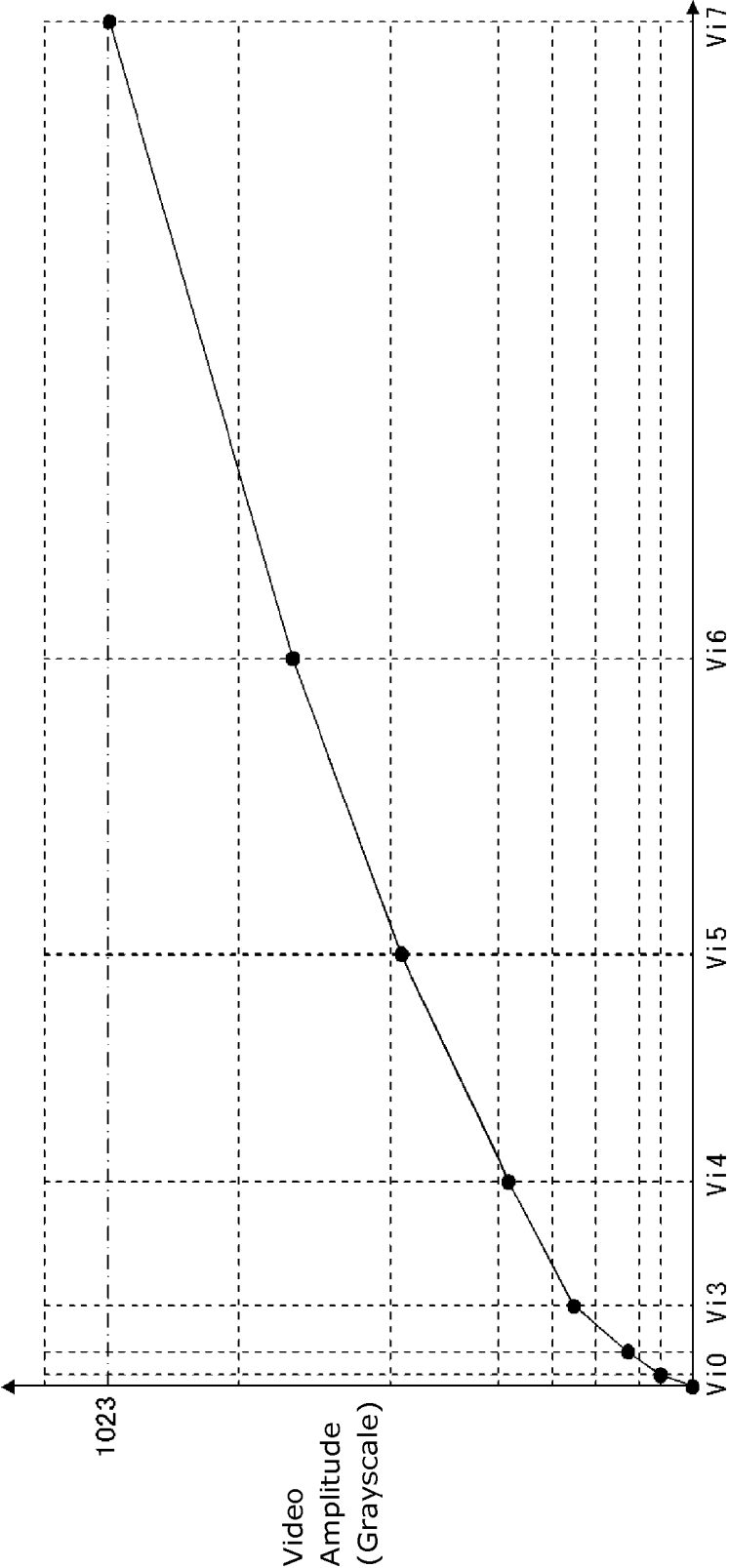

FIG. 43

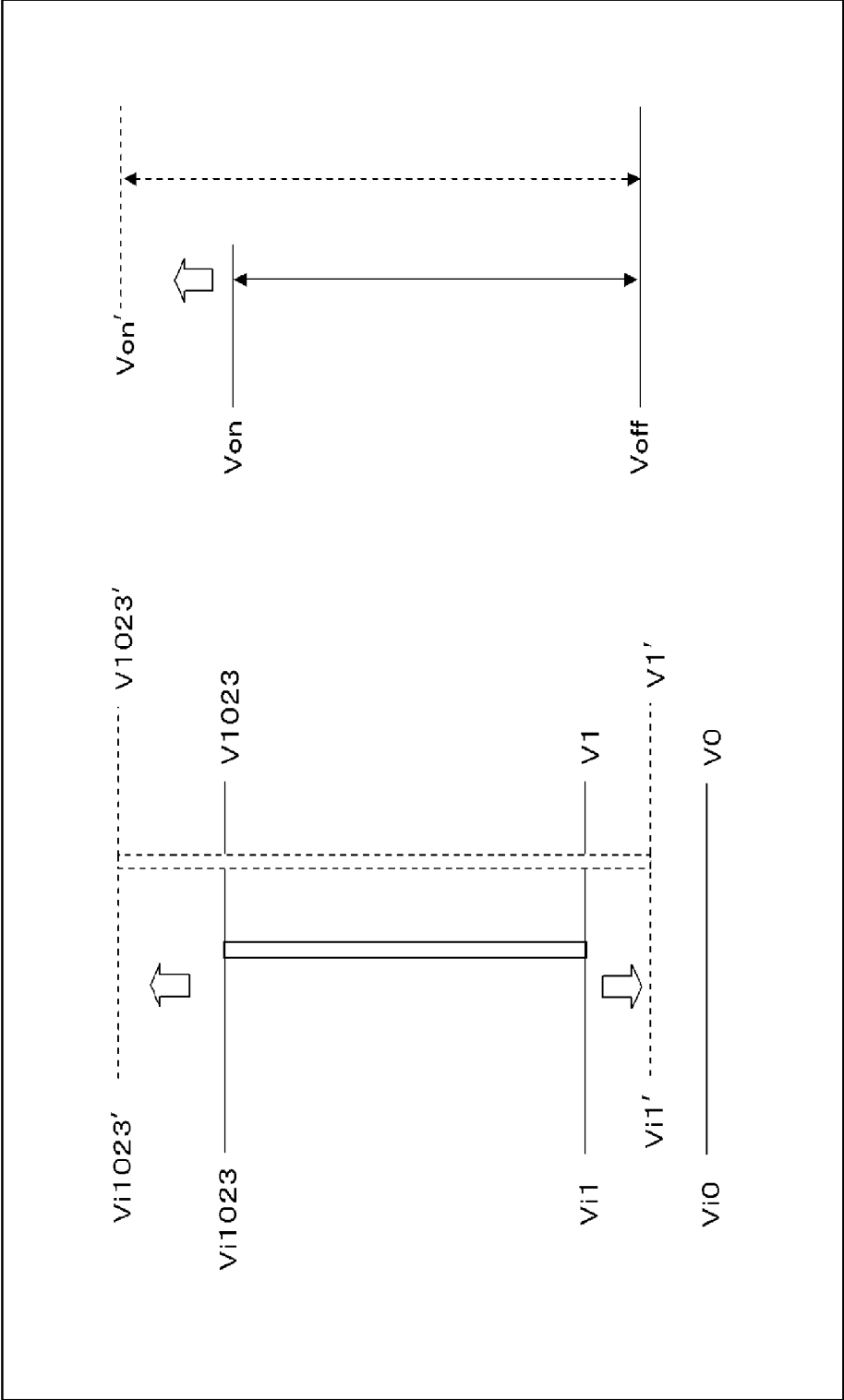

FIG. 44

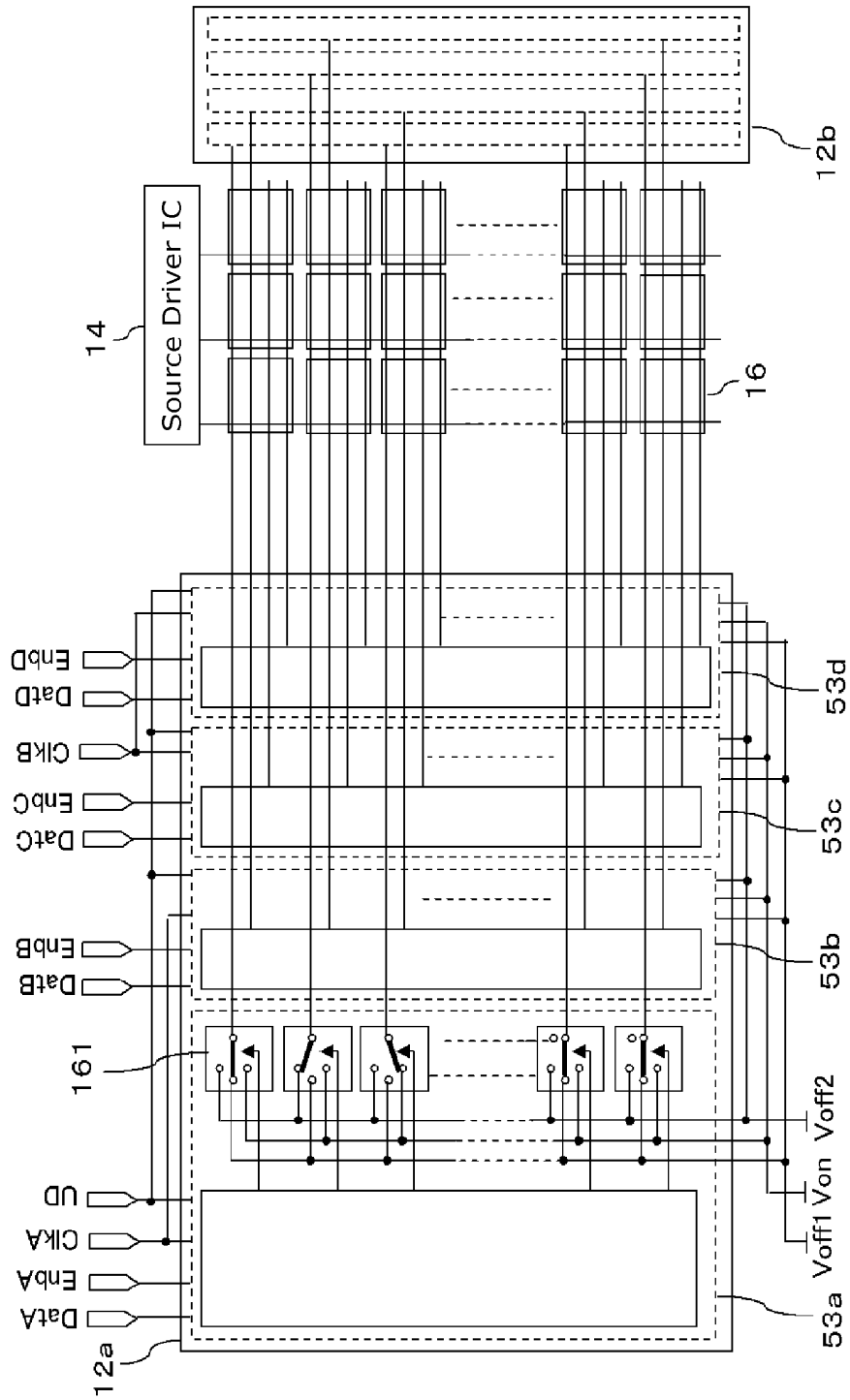

FIG. 45

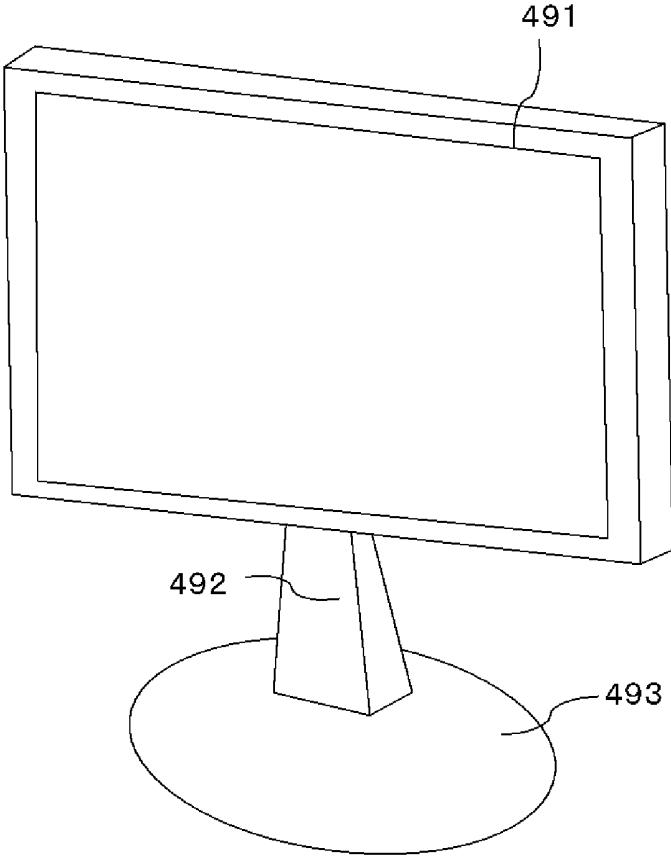

FIG. 46

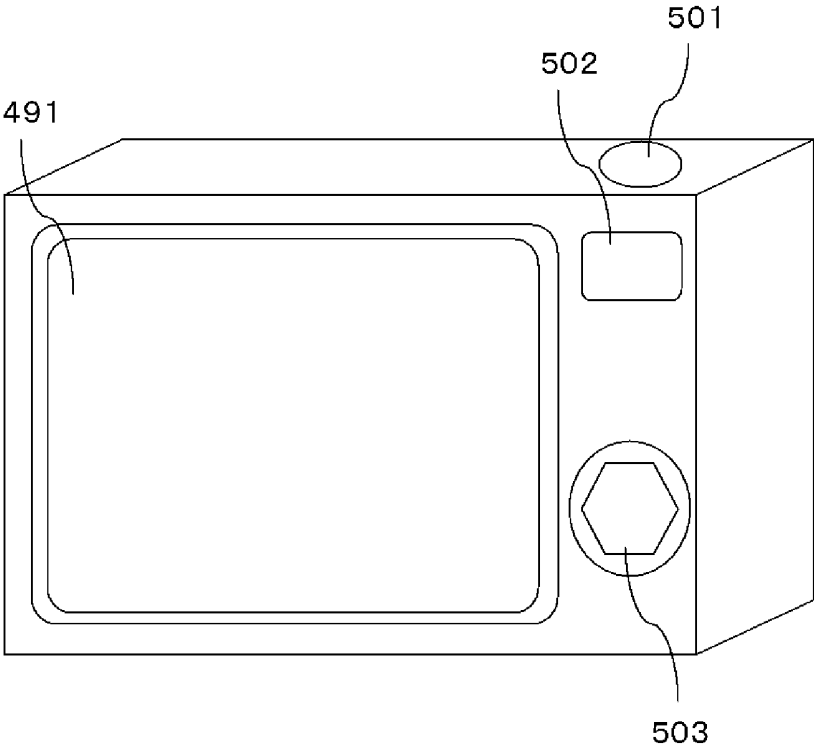
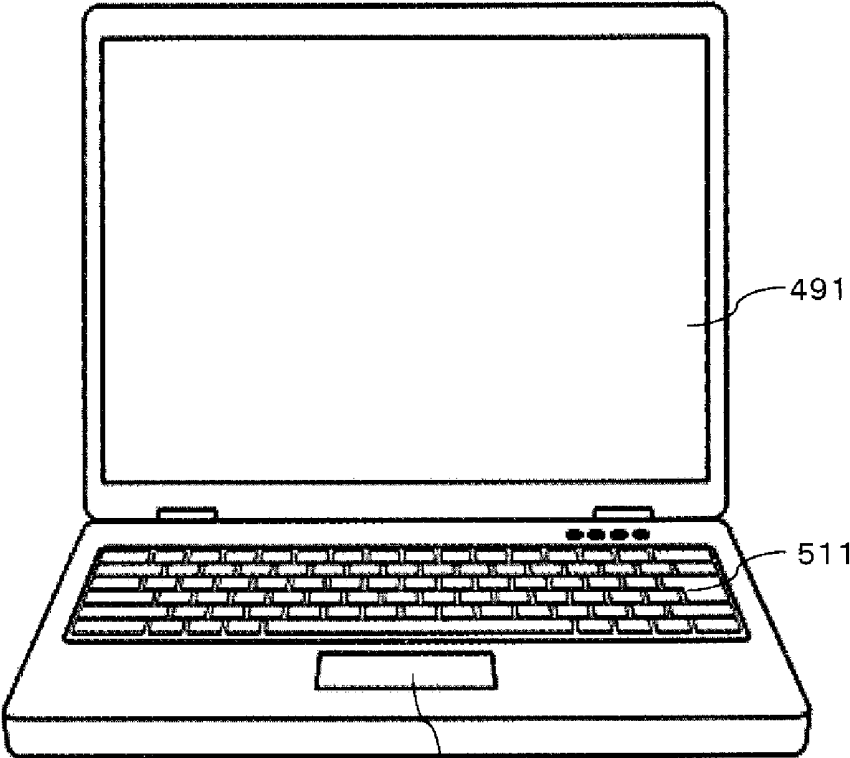

FIG. 47



512

FIG. 48

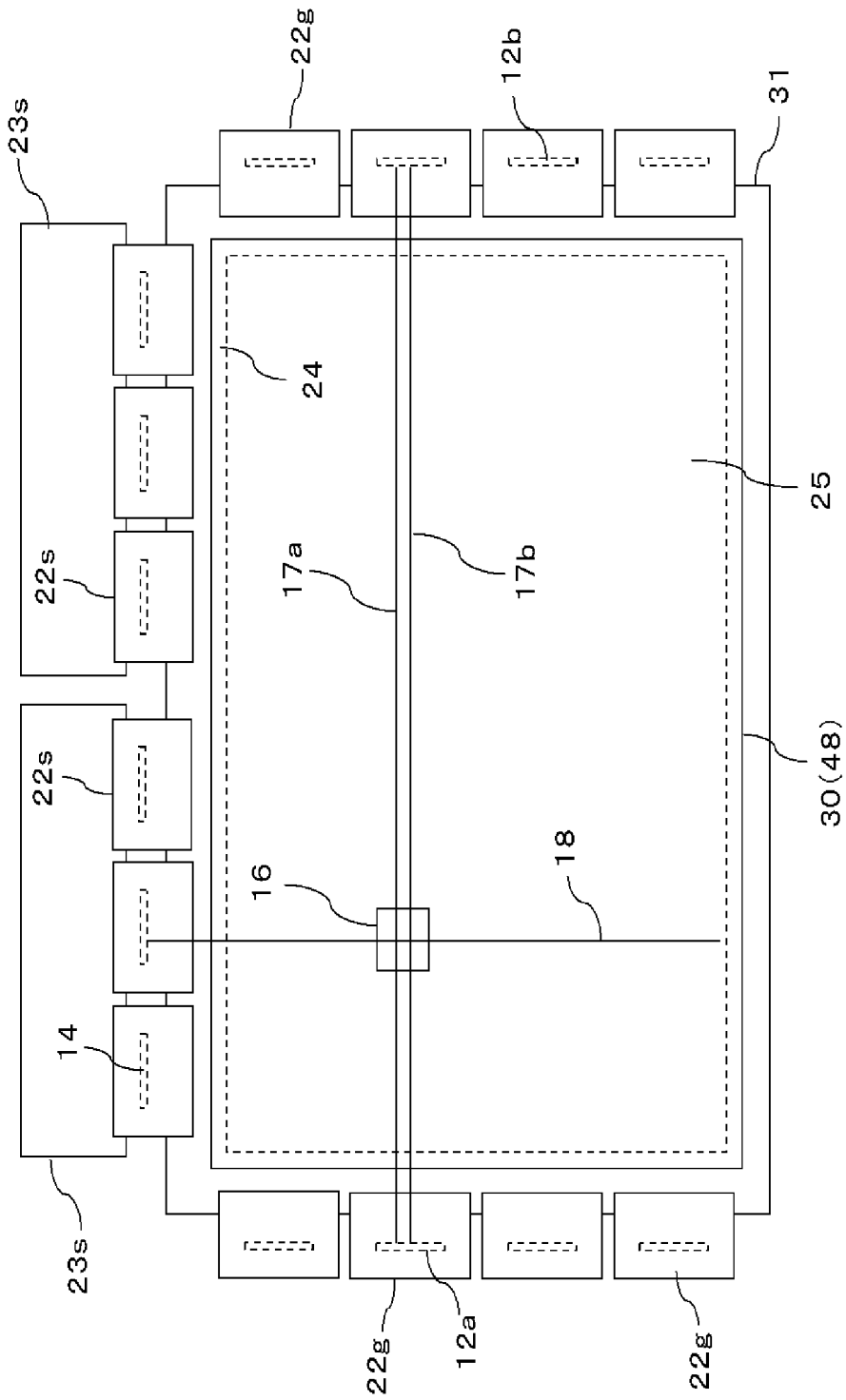

FIG. 49

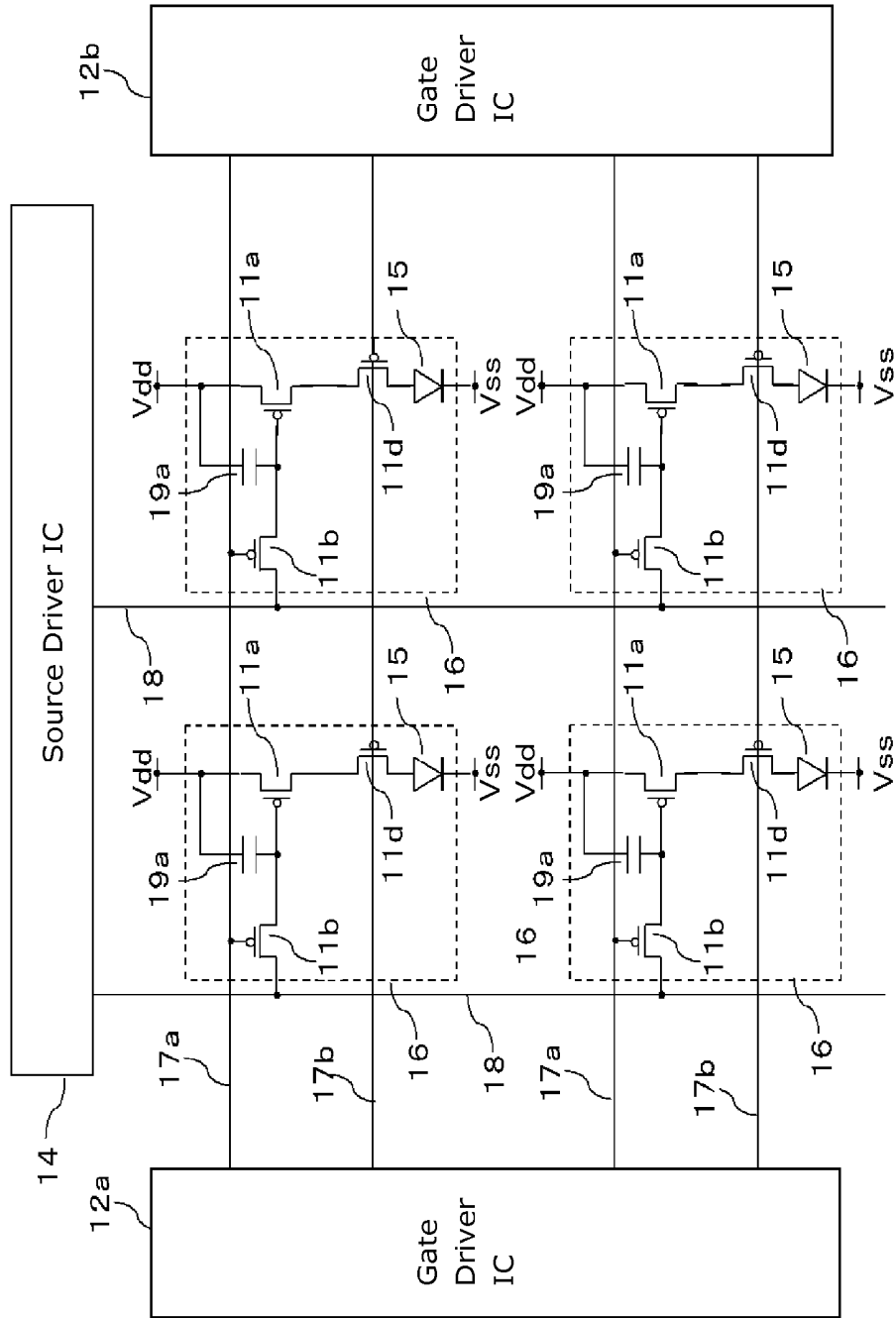
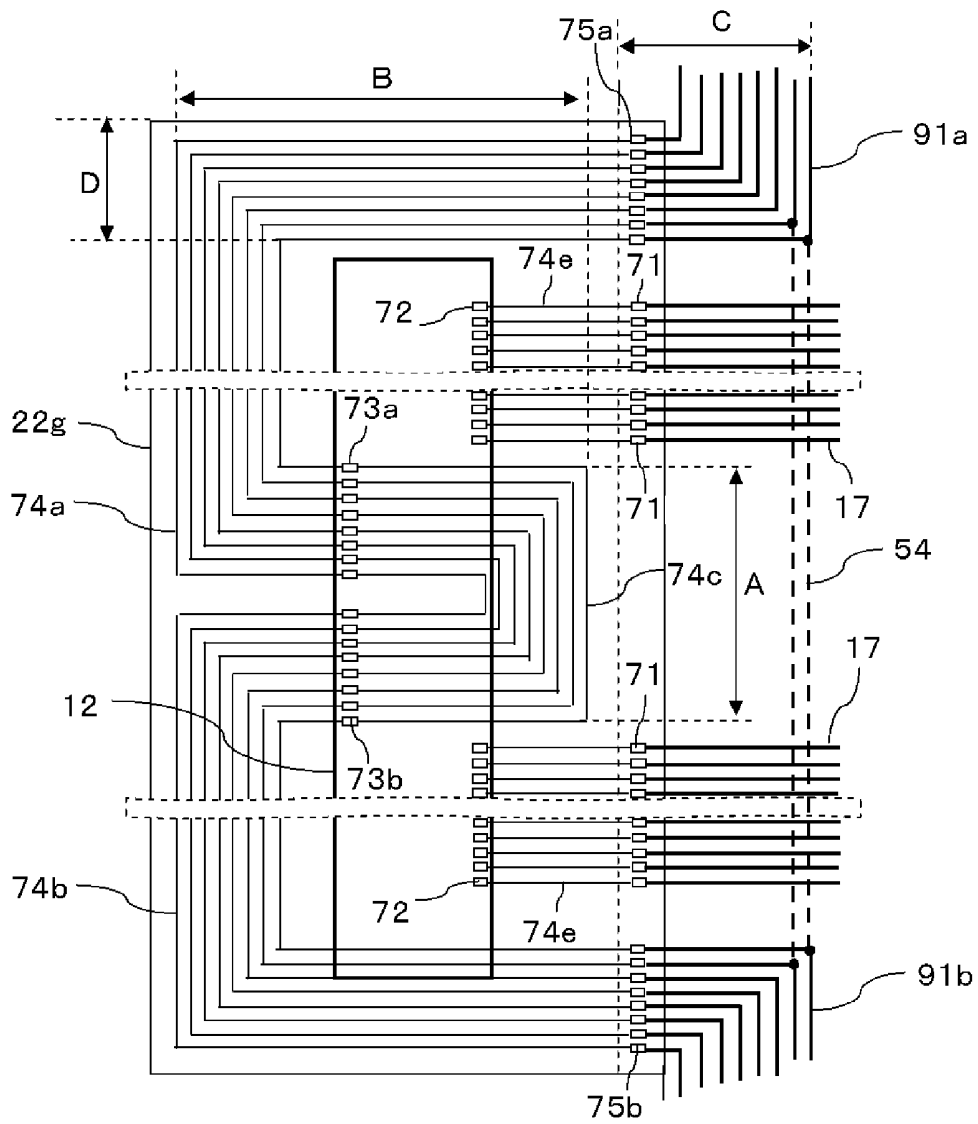

FIG. 50



ELECTROLUMINESCENT DISPLAY

TECHNICAL FIELD

[0001] The present disclosure relates to pixel configurations made up of pixels each including, for example, an organic electro-luminescence element (hereinafter also referred to as an EL or an OLED), EL displays (EL display panels) on which EL elements are arranged in a matrix, EL display driving methods, driver IC boards for use in EL displays, flexible boards, etc.

BACKGROUND ART

[0002] Active-matrix (hereinafter also referred to as AM) organic EL displays on which organic EL elements are arranged in a matrix have been employed as display panels for products such as smartphones. Each EL element has an EL layer between an anode electrode and a cathode electrode. The EL element emits light triggered by a current or a voltage supplied between the anode and cathode electrodes (terminals) (for example, see Patent Literature 1).

[0003] The liquid crystal display panel (LCD) includes gate signal lines arranged on a per pixel basis. EL displays each include pixels each including at least two gate signal lines formed or arranged therein, and most of the EL displays include pixels through which three or four gate signal lines are formed or arranged (for example, see Patent Literature 2).

[0004] Patent Literature 1 discloses a configuration in which connection transmission lines which electrically connect input transmission lines and output transmission lines on a flexible board (COF (chip on film)) mounting driver ICs of an active-matrix (this may be abbreviated as AM below) organic EL display having organic EL elements in the shape of a matrix.

[0005] Patent Literature 2 discloses a configuration in which input signal lines etc. are formed in serial connection on a flexible board mounting driver ICs.]

CITATION LIST

Patent Literature

[PTL 1]

[0006] Japanese Unexamined Patent Application Publication No. 2007-188078

[PTL 2]

[0007] Japanese Unexamined Patent Application Publication No. 2006-049514

SUMMARY OF INVENTION

Technical Problem

[0008] An EL display (EL display panel) does not require a backlight for image display, and thus can be provided with a thin panel module. In order to take advantage of the feature of being able to provide the EL display with such a thin panel, a configuration (PCB-less configuration) without any printed circuit board (PCB) is employed for a gate driver IC side.

[0009] In the PCB-less configuration, all of power supply lines and control signal lines need to be formed in a COF. The COF has only a single wiring layer, and thus lines formed in the COF cannot intersect each other. For this reason, there is

a need to layout the lines etc. in serial connection so as not to generate any intersection parts of the power supply lines and control lines.

[0010] However, since the EL display (EL display panel) has a large number of control signal lines, the density of the lines to be formed on the COF is large, and thus a short circuit defect is likely to occur.

[0011] The present disclosure was made considering these problems, and has an object to provide EL displays with a reduced number of control lines formed in serial connection on their COFs, with a high yield rate at low cost.

Solution to Problem

[0012] The EL display according to an aspect of the present disclosure includes a panel board on which a plurality of luminescence elements are arranged, and a flexible board on which gate driver ICs for driving the panel board are mounted.

[0013] An EL display according to the present disclosure includes: a panel board including a display screen on which pixels each including an EL element are arranged in a matrix; gate signal lines arranged on a per pixel row basis; source signal lines arranged on a per pixel column basis; gate driver circuits mounted on a flexible board; and a source driver circuit which outputs a video signal to the source signal lines. Each of the gate driver circuits includes gate signal output terminals, driver terminals, and control terminals. First connection parts, gate signal connection parts, second connection parts, and third connection parts are arranged on a side of the flexible board. The flexible board includes (i) terminals connection lines which connect terminals and the gate signal connection parts, and (ii) one or more serial connection lines which connect at least two of the connection parts. The control terminals are arranged between the gate signal output terminals and the driver terminals. The gate signal connection parts and the gate signal output terminals are connected with terminal connection lines. The first connection parts, the driver terminals, and the third connection parts are connected with the serial connection lines. Panel lines formed on the panel board are connected to the second connection parts. The second connection parts and the control terminals are connected with terminal connection lines. With this configuration, it is possible to reduce the number of control lines to be formed in serial connection on the COF, and thereby to provide the EL display at low cost, resulting in a high yield rate.

[0014] It is to be noted that the driver terminals of the EL display according to the present disclosure may be driver terminals which apply a voltage to the gate driver ICs.

Advantageous Effects of Invention

[0015] According to the present disclosure, it is possible to reduce the number of control lines to be formed in serial connection on each of the COFs, and thereby to provide EL displays at low cost, resulting in a high yield rate.

BRIEF DESCRIPTION OF DRAWINGS

[0016] FIG. 1 is a cross sectional view of a configuration of an EL display according to an embodiment.

[0017] FIG. 2 is a cross sectional view of a configuration of an EL display according to an embodiment.

[0018] FIG. 3 is a diagram for explaining an EL display according to an embodiment.

[0019] FIG. 4 is a diagram for explaining a gate driver IC of the EL display according to the embodiment.

[0020] FIG. 5 is a diagram for explaining an EL display according to an embodiment.

[0021] FIG. 6 is a diagram for explaining a COF for use in an EL display according to an embodiment.

[0022] FIG. 7 is a diagram for explaining a COF for use in an EL display according to an embodiment.

[0023] FIG. 8A is a diagram for explaining a gate driver IC of an EL display according to an embodiment.

[0024] FIG. 8B is a diagram for explaining a gate driver IC of an EL display according to an embodiment.

[0025] FIG. 9 is a diagram for explaining a gate driver IC of an EL display according to an embodiment.

[0026] FIG. 10 is a diagram for explaining a gate driver IC for use in an EL display according to an embodiment.

[0027] FIG. 11 is a diagram for explaining an EL display according to an embodiment.

[0028] FIG. 12 is a diagram for explaining a COF part of an EL display according to an embodiment.

[0029] FIG. 13 is a diagram for explaining a gate driver IC for use in an EL display according to an embodiment.

[0030] FIG. 14 is a diagram for explaining a gate driver IC of an EL display according to an embodiment.

[0031] FIG. 15 is a diagram for explaining a gate driver IC of an EL display according to an embodiment.

[0032] FIG. 16 is a diagram for explaining a gate driver IC of an EL display according to an embodiment.

[0033] FIG. 17 is a diagram for explaining a gate driver IC of an EL display according to an embodiment.

[0034] FIG. 18 is a diagram for explaining a gate driver IC of an EL display according to an embodiment.

[0035] FIG. 19 is a diagram for explaining a gate driver IC of an EL display according to an embodiment.

[0036] FIG. 20A is a diagram for explaining a method for driving an EL display according to an embodiment.

[0037] FIG. 20B is a diagram for explaining a method for driving an EL display according to an embodiment.

[0038] FIG. 21 is a diagram for explaining a method for driving an EL display according to an embodiment.

[0039] FIG. 22A is a diagram for explaining a gate driver IC for use in an EL display according to an embodiment.

[0040] FIG. 22B is a diagram for explaining a gate driver IC for use in an EL display according to an embodiment.

[0041] FIG. 23 is a diagram for explaining an EL display according to an embodiment.

[0042] FIG. 24 is a diagram for explaining an EL display according to an embodiment.

[0043] FIG. 25 is a diagram for explaining the EL display according to the embodiment.

[0044] FIG. 26 is a diagram for explaining an EL display according to an embodiment.

[0045] FIG. 27 is a diagram for explaining the EL display according to the embodiment.

[0046] FIG. 28 is a diagram for explaining the EL display according to the embodiment.

[0047] FIG. 29 is a diagram for explaining one of the gate driver ICs of the EL display according to the embodiment.

[0048] FIG. 30A is a diagram for explaining a method for driving an EL display according to an embodiment.

[0049] FIG. 30B is a diagram for explaining a method for driving the EL display according to the embodiment.

[0050] FIG. 31A is a diagram for explaining a method for driving the EL display according to the embodiment.

[0051] FIG. 31B is a diagram for explaining a method for driving the EL display according to the embodiment.

[0052] FIG. 32A is a diagram for explaining a method for driving the EL display according to the embodiment.

[0053] FIG. 32B is a diagram for explaining a method for driving the EL display according to the embodiment.

[0054] FIG. 33A is a diagram for explaining a method for driving the EL display according to the embodiment.

[0055] FIG. 33B is a diagram for explaining a method for driving the EL display according to the embodiment.

[0056] FIG. 34A is a diagram for explaining a method for driving the EL display according to the embodiment.

[0057] FIG. 34B is a diagram for explaining a method for driving the EL display according to the embodiment.

[0058] FIG. 35 is a diagram for explaining a method for driving an EL display according to an embodiment.

[0059] FIG. 36 is a diagram for explaining a method for driving the EL display according to the embodiment.

[0060] FIG. 37 is a diagram for explaining a method for driving the EL display according to the embodiment.

[0061] FIG. 38 is a diagram for explaining a method for driving the EL display according to the embodiment.

[0062] FIG. 39 is a diagram for explaining a method for driving the EL display according to the embodiment.

[0063] FIG. 40 is a diagram for explaining a method for driving the EL display according to the embodiment.

[0064] FIG. 41 is a diagram for explaining a gate driver IC of an EL display according to an embodiment.

[0065] FIG. 42 is a diagram for explaining a source driver IC for use in an EL display according to an embodiment.

[0066] FIG. 43 is a diagram for explaining a source driver IC for use in an EL display according to an embodiment.

[0067] FIG. 44 is a diagram for explaining a method for driving an EL display according to an embodiment.

[0068] FIG. 45 is a diagram for explaining a display apparatus including an EL display according to an embodiment.

[0069] FIG. 46 is a diagram for explaining a display apparatus including an EL display according to an embodiment.

[0070] FIG. 47 is a diagram for explaining a display apparatus including an EL display according to an embodiment.

[0071] FIG. 48 is a diagram for explaining an EL display.

[0072] FIG. 49 is a diagram for explaining an EL display.

[0073] FIG. 50 is a diagram for explaining a COF part of a conventional EL display.

DESCRIPTION OF EMBODIMENTS

[0074] Hereinafter, embodiments are described in detail referring to the drawings as appropriate. Unnecessarily detailed descriptions may be omitted. For example, already well-known matters may not be described in detail, and substantially the same configurations may not be described repeatedly. This omission etc. is performed to prevent the following descriptions from being unnecessarily redundant, and to thereby allow any person skilled in the art to easily understand the descriptions.

[0075] The Inventors provide the attached drawings and the following descriptions to allow the person skilled in the art to fully understand the present disclosure, without any intention to limit the subject matter of the claims by the drawings and descriptions.

(Underlying Knowledge Forming Basis of the Present Disclosure)

[0076] The underlying knowledge forming the basis of the present disclosure is described before the present disclosure is described in detail.

[0077] A liquid crystal display panel (LCD) includes gate signal lines formed or arranged on a per pixel basis. On the other hand, an EL display (hereinafter also referred to as an "EL display panel" in the embodiments) includes gate signal lines formed or arranged such that at least two gate signal lines pass through each of pixels. For example, in most EL displays, three or four gate signal lines are formed or arranged on a per pixel basis.

[0078] In view of the above-described matters, the EL displays are configured to have a considerably larger number of gate signal lines than that of the LCDs.

[0079] An LCD requires an on voltage (Von), an off voltage (Voff), a logic voltage (Vcc), and a video signal voltage (AVdd).

[0080] An EL display requires several kinds of on voltages (Von) and also several kinds of off voltages (Voff). The EL display requires also a video signal voltage (AVdd) and a logic voltage (Vcc). The EL display may require an initial voltage (Vini), a reset voltage (Vrst) etc. depending on a pixel circuit configuration. The EL display also requires an anode voltage (Vdd) and a cathode voltage (Vss). In addition, the plurality of gate signal lines each of which controls a corresponding one of pixels operate differently, and control signals for controlling the respective gate signal lines to operate are also required. For this reason, the number of control signals is also large. Accordingly, the number of control signal lines and the number of power supply lines in the EL display are four to five times larger than those of the LCD.

[0081] As illustrated in FIG. 48, gate driver ICs 12 (12a, 12b) and source driver ICs (source driver circuits) 14 are mounted on a COF. In addition, as illustrated in FIG. 48, both ends of gate signal lines 17a and 17b are connected to the gate driver ICs 12 (12a, 12b). The gate driver ICs 12 (12a, 12b) are mounted on each of COFs 22g.

[0082] Likewise, each pixel 16 is connected to a corresponding one of source signal lines 18. Each source signal line 18 has an end connected to a corresponding one of the source driver ICs 14 mounted on a corresponding one of the COF 22s. A printed circuit board (PCB) is connected to the corresponding COF 22s, and a video signal and a control signal are applied from the printed board (PCB) to the corresponding COF 22s.

[0083] COFs 22s with the source drivers IC 14 are mounted onto a panel. In addition, a printed circuit board (PCB) 23s is attached to each COF 22s.

[0084] In the present disclosure, circuits for driving gate signal lines are described as gate driver ICs 12, but the present disclosure is not limited thereto. For example, the gate driver ICs 12 may be directly formed on a display panel board at the same time when processes of forming a pixel circuit etc. are performed, according to a technique using TAOS, or a low or high temperature polysilicon. In other words, the gate driver ICs are not limited to semiconductor chips, and means gate driver circuits. This applies to the source driver ICs 14, that is, the source driver ICs are not limited to semiconductor chips, and means source driver circuits. Needless to say, no COF is required when driver ICs are directly formed onto a display panel board at the same time when processes of forming a

pixel circuit etc. are performed, according to the technique using TAOS, or a low or high temperature polysilicon.

[0085] The COF 22g with the gate driver ICs 12 is also mounted onto the panel. No printed circuit board (PCB) is attached to the COF 22g. Stated differently, this is a configuration without any printed circuit board (PCB-less configuration). By employing such a printed circuit board without any PCB (the PCB-less configuration), a thin panel module can be configured.

[0086] FIG. 49 is a diagram for explaining pixels, driver ICs, etc. of an EL display.

[0087] In each of pixels 16 in FIG. 49, the source terminal of a switch transistor 11d is connected to the drain terminal of a P-channel driver transistor 11a, and the anode terminal of an EL element 15 is connected to the drain terminal of the switch transistor 11d.

[0088] A cathode voltage Vss is applied to the cathode terminal of an EL element 15. An anode voltage Vdd is applied to the source terminal of the driver transistor 11a.

[0089] When an on voltage is applied to a gate signal line 17b (Gd), the switch transistor 11d is turned on, and a current for light emission is supplied from the driver transistor 11a to the EL element 15. The EL element 15 emits light based on the magnitude of the current for light emission. The magnitude of the current for light emission is determined by applying the pixel 16 with a video signal applied to a source signal line 18, using a switch transistor 11b.

[0090] A terminal of a capacitor 19b is connected to the gate terminal of the driver transistor 11a, and the other terminal of the capacitor 19b is connected to an electrode or seven lines to which an anode voltage (Vdd) is applied. The source terminal of the switch transistor 11b is connected to the source signal line 18, and the drain terminal of the switch transistor 11b is connected to the gate terminal of the driver transistor 11a. On the other hand, a source driver IC 14 applies the source signal line 18 with a video signal.

[0091] The gate signal lines 17 (17a, 17b) are connected to the gate driver ICs 12 (12a, 12b) arranged right and left of a display screen 25.

[0092] The gate driver ICs 12 (12a, 12b) apply selection voltages (on voltages Von) of the pixels 16 to the gate signal lines 17. The applied on voltages of the gate signal lines 17b turn on the switch transistors 11b, and video signals applied to the source signal lines 18 are applied to the pixels 16.

[0093] An EL display panel 49 has the display screen 25 on which the pixels 16 each including the EL element 15 are arranged in a matrix.

[0094] With the configuration, even when the display screen is large or for high definition display, it is possible to apply the pixels on the display screen with video signals effectively. In addition, it is possible to prevent luminance slope from occurring on the display screen, and provide excellent image display.

[0095] It is to be noted that the driver terminals of the EL display according to the present disclosure may be driver terminals which apply voltages to the gate driver ICs.

[0096] In addition, an EL display does not require a backlight for image display, and thus can be provided with a thin panel module. In order to take advantage of the feature of being able to provide the EL display with such a thin panel, a PCB-less configuration is employed for the gate driver ICs 12 (12a, 12b) side as illustrated in FIG. 48.

[0097] When PCBs are used, it is only necessary that power supply lines and control signal lines for use in the gate driver ICs 12 (12a, 12b) are supplied from the PCBs.

[0098] In the configuration without any PCB (PCB-less configuration) as illustrated in FIG. 48, all of the power supply lines and control lines need to be formed on the COF 22g as illustrated in FIG. 50. The COFs have only a single wiring layer, and thus lines formed on the COFs 22 cannot intersect each other. For this reason, there is a need to perform wiring layout etc. in serial connection so as not to generate any intersection parts of the power supply lines and control lines as illustrated in FIG. 50.

[0099] In FIG. 50, a panel line 91a formed on a panel board 31 and a COF line 74a of the COF 22g are connected using an ACF resin at a connection terminal 75a. The COF line 74a is electrically connected to a driver input terminal 73a of a gate driver IC 12. The driver input terminal 73a and a driver input terminal 73b are connected through a COF line 74c. In addition, the driver input terminal 73b and a connection terminal 75b are electrically connected through a COF line 74b. In addition, a panel line 91b formed on the panel board 31 and the COF line 74b of the COF 22g are connected using the ACF resin at a connection part 75b.

[0100] As described above, the wiring layout is realized on the panel board 31 in the following serial connection: from the panel line 91a via the connection terminal 75a via the COF line 74a via the driver input terminal 73a via the COF line 74c via the driver input terminal 73b via the COF line 74b via the connection terminal 75b to the panel line 91b.

[0101] It is to be noted that outputs of the gate driver ICs 12 are output from driver output terminals 72. The driver output terminals 72 and connection terminals 71 are electrically connected through COF lines 74e. The driver output terminals 72 are electrically connected to gate signal lines 17 using ACF resin.

[0102] EL displays each include pixels passed through by at least two gate signal lines, and most of the EL displays include pixels passed through by three or four gate signal lines.

[0103] In view of the above-described matters, the EL displays are configured to have a considerably larger number of signal lines than that of the LCDs. Accordingly, the number of control signal lines for controlling the gate signal lines 17 etc. is also large.

[0104] The respective gate signal lines of the pixels are for controlling different transistors, and require different voltage amplitudes. Accordingly, an EL display requires several kinds of on voltages (Von) and also requires several kinds of off voltages (Voff). In addition, an initial voltage (Vini) and a reset voltage (Vrst), etc. may be required. In addition, the plurality of gate signal lines each of which controls a corresponding one of pixels operate differently, and control signals for controlling operations of the respective gate signal lines are also required. For this reason, the number of control signals is also large. Accordingly, the number of control signal lines and the number of power supply lines in the EL display are four to five times larger than those in an LCD.

[0105] Since the EL display has such a large number of power supply lines and such a large number of control lines, the number of lines to be formed on the COF 22g is extremely large. In general, the number is three times larger than that of the LCD.

[0106] Since the number of power supply lines and the number of control lines to be formed on the COF are large as

illustrated in FIG. 48, Distance D, Distance A, and Distance B of the COF 22g in FIG. 50 need to be long in order to realize such a PCB-less configuration. For this reason, the size of the COF 22g needs to be large, increasing the cost. The display screen size of the EL display is determined by the inches of the display screen of the panel, and thus the distance usable in COF mounting (the width within which the COFs can be attached) is also determined by the inches of the display screen of the panel. Accordingly, if the size of COFs is too large, the distance usable in COF mounting (the width within which the COFs can be attached) exceeds the width of the display screen. For this reason, if the size of COFs is increased too much, it is physically impossible to mount the COFs on a panel.

[0107] If Distance A in the COF 22g is long, the range within which the driver output terminals 72 are formed is reduced. Alternatively, the long sides of the chips of the gate drivers IC 12 need to be lengthened. This results in increase in the size of the gate driver ICs 12, increasing the price of the gate driver ICs.

[0108] In order to reduce the number of COF lines 74 to be formed on the COF 22g, a means for forming array connection lines 54 as illustrated in FIG. 50 is conceivable. The array connection lines 54 are formed in a process of forming pixels on the panel, and thus intersection parts of lines can be formed. Accordingly, a complex wiring pattern and branches of lines can be formed.

[0109] However, since the array connection lines 54 each intersects with the gate signal lines 17, if a pin hole exists at any of the intersection parts, the corresponding one of the array connection lines 54 and the gate signal lines 17 is short circuited. The EL display has a large number of gate signal lines 17. For this reason, the number of gate driver output terminals per gate driver IC 12 is also large. Accordingly, the number of intersection parts between the array connection lines 54 and the gate signal lines 17 is large, and thus short-circuit defects are likely to occur. In particular, the part on which the array connection lines 54 are formed is not provided with any protection cover, and is likely to be damaged mechanically. For this reason, short-circuit defects are likely to occur at the intersection parts.

[0110] In view of the above, the COFs 22g with the gate driver ICs 12 are mounted on and connected to the panel board 31, and, in the EL display having such a PCB-less configuration has the constraints below.

[0111] One of the constraints is (1) the lines 74 formed on each COF 22g cannot intersect with any line. The other is (2) the gate signal lines 17 on the panel board cannot intersect with the input signal lines and the power lines, or if the gate signal lines 17 on the panel board intersect with the input signal lines and the power lines, there is a high risk that any of the intersection parts is short-circuited, resulting in a significant reduction in the panel manufacturing yield.

[0112] As described above, it was difficult to provide an EL display having a panel board 31 on and to which COFs 22g with gate driver ICs 12 are mounted and connected and has such a PCB-less configuration.

[0113] In view of this, in embodiments below, descriptions are given of EL displays each having a reduced number of control lines formed in serial connection on a COF, and thereby reducing the cost and increasing the yield.

EMBODIMENTS

[0114] Hereinafter, displays according to embodiments are described with reference to FIGS. 1 to 8B.

[0115] Each of FIGS. 1 and 2 is a cross sectional view of a configuration of the EL display according to an embodiment.

[0116] In the present disclosure, the drawings include omitted, magnified or reduced portions for help understanding or creation of the drawings. For example, a glass substrate 48 etc. are thin in the cross sectional view of a display panel illustrated in FIG. 1. In FIG. 2, a sealing substrate 30 is thin.

[0117] Examples of omitted parts are indicated below. In the EL display in FIG. 1 according to the present disclosure, it is necessary to arrange a phase film such as a circularly polarizing plate for prevention of reflected light on a light emission surface. However, in FIG. 1, such a circularly polarizing plate is not illustrated.

[0118] On the light emission surface, a glareproof sheet having an uneven surface is formed or arranged in order to prevent natural light from being reflected on the light emission surface. However, such a glareproof sheet is not illustrated in FIGS. 1 and 2. A sheet of a reflection prevention film or a reflection prevention film is not illustrated in the drawings, either.

[0119] In the following descriptions, the connection terminal 75a corresponds to a first connection part in the present disclosure. The connection terminal 71 corresponds to a gate signal connection part in the present disclosure. The connection terminal 75b corresponds to a third connection part in the present disclosure. The driver output terminals 72 correspond to gate signal output terminals in the present disclosure. The driver input terminals 73a and 73b correspond to driver terminals in the present disclosure. The connection terminal 75c corresponds to a second connection part in the present disclosure. The COF lines 74a, 74b, and 74c correspond to serial connection lines in the present disclosure. The COF lines 74d and 74e correspond to terminal connection lines in the present disclosure. Input control lines 261 correspond to panel lines in the present disclosure.

[0120] Each of FIGS. 1 and 2 is a cross sectional diagram of an EL display panel according to the present disclosure. Parts unnecessary for explanation are not illustrated. The thickness, size, etc. of some part are magnified or reduced to simplify explanation. The above-described matters apply to the other drawings.

[0121] FIG. 1 illustrates the embodiment that is a display for "top light extraction" in which light is extracted from a top surface of a panel board 31. FIG. 2 illustrates the embodiment that is a display for "bottom light extraction" in which light is extracted from a bottom surface of a panel board 31.

[0122] A sealing substrate 30 and the panel board 31 are each, for example, a glass substrate. Each of the sealing substrate 30 and the panel board 31 may be formed using a silicon wafer, a metal substrate, a ceramic substrate, a plastic sheet (plate), or the like. In order to provide excellent heat dissipation, each of the sealing substrate 30 and the panel board 31 may of course be made of sapphire glass, or the like.

[0123] As illustrated in FIG. 2, a drying agent (not illustrated) is placed in a space between a sealing substrate 30 and a panel board 31. This is because an EL film 41 is susceptible to humidity. The drying agent absorbs water content infiltrated in a sealing agent (not illustrated), and prevents the EL film 41 from deteriorating. In addition, the peripheral parts of the sealing substrate 30 and the panel board 31 are sealed with a sealing resin (not illustrated).

[0124] The sealing substrate 30 has, for example, a cap shape. The sealing substrate 30 is a means for preventing or controlling infiltration of water content from outside, and the shape thereof is not limited to the cap shape. The sealing substrate 30 may be made of fusion glass. Alternatively, the sealing substrate 30 may be a compound of a resin, an inorganic material, or/and the like. The sealing substrate 30 is formed to be a thin film using vapor deposition technique or the like.

[0125] Temperature sensors (not illustrated) are formed or arranged in a space between the sealing substrate 30 and the panel board 31, on e.g. a surface of the sealing substrate 30. Depending on the results of outputs from these temperature sensors, the amplitudes of videos output from a source driver IC 14 etc. are varied. In addition, at the time when the panel is tested, the operation speeds of gate drivers IC 12 are adjusted based on the temperatures output from these temperature sensors. With the speed adjustment, appropriate operation speeds can be set.

[0126] A COF in the present disclosure is formed to absorb light by applying or forming a light absorbing composition or material to a surface of the COF, or bonding a sheet to the surface thereof. In addition, a heat dissipation plate is arranged or formed on the surfaces of driver ICs mounted on the COF, so as to dissipate heat from the driver ICs. In addition, a heat dissipation sheet and a heat dissipation plate are arranged or formed on the rear surface of the COF, so as to dissipate heat from the driver ICs.

[0127] In FIG. 2, on the panel board 31, color filters 33 (33R, 33G, 33B) representing red (R), green (G), and blue (B) are formed. The color filters for use are not limited to RGB. Pixels of cyan (C), magenta (M), and yellow (Y) may be formed.

[0128] Here, aperture rates of R, G, and B pixels may be varied. By varying the aperture rates, it is possible to vary the densities of currents flowing in the respective R, G, and B EL elements 15. By varying the densities of currents, it is possible to equalize deterioration speeds of the respective R, G, and B EL elements 15. By equalizing the deterioration speeds, the white balance of the EL display is retained.

[0129] The display in the present disclosure has pixels 16W of W (white), in addition to pixels of three primary colors of RGB. An excellent color peak luminance can be obtained by forming or arranging the pixels 16W. Furthermore, a high luminance display can be realized.

[0130] Each of the pixels 16 of the EL panel (EL display) in the present disclosure is configured to have switch transistors 11 and an EL element 15 as illustrated in FIG. 49, etc.

[0131] An insulation layer is formed between gate signal lines 17 etc. and color filters 33, but the insulation layer is not illustrated because no explanation thereof is necessary. This applies to the other embodiments.

[0132] As illustrated in FIG. 2, anode electrodes 40 is configured to overlap with gate signal lines 17. Alternatively, in most cases, the gate signal lines 17 and the anode electrodes 40 are arranged in an overlapped manner in designing a pattern layout.

[0133] An insulation film 34 is formed on the color filters 33 (33R, 33G, and 33B). The insulation film 34 prevents EL films 41 etc. from deteriorating due to water content exuded from the color filters 33. The insulation film 34 functions also as a smoothing film.

[0134] Transistors 11 which constitute pixels 16 are formed on a layer above the color filters 33. A light blocking film 36

is formed on the transistors 11. As necessary, a light blocking film 36 is formed on a layer below the transistors 11, and a layer below or above gate driver circuits. The anode electrodes 40 and the transistors 11 are connected at connection parts 37.

[0135] The light blocking film 36 is formed with a metal thin film made of chromium or the like, to have a film thickness ranging from 50 nm to 150 nm inclusive. A thin light blocking film 36 provides a small light blocking effect, while a thick light blocking film 36 makes it difficult to pattern transistors 11 in a layer above the light blocking film 36 due to unevenness of the light blocking film 36.

[0136] By arranging or forming source signal lines 18, the anode electrodes 40 or cathode electrodes above the gate signal lines 17, electric fields from the source signal lines 18 and the gate signal lines 17 are blocked by the anode electrodes 40 or the cathode electrodes. With this blocking, it is possible to reduce noise in image display.

[0137] An insulation film or an insulation film (planarizing film) 34 made of an acrylic material is formed to insulate the source signal lines 18 and the gate signal lines 17, and the anode electrodes 40 are formed on the insulation film 34.

[0138] Such a configuration in which the anode electrodes 40 are overlapped at least partly above the gate signal lines 17 etc. is referred to as a high aperture (HA) structure. This configuration reduces unnecessary interference light etc. and realizes an excellent light emission state.

[0139] The insulation film (planarizing film) 34 functions also as an inter-layer insulation film. The insulation film (planarizing film) 34 reduces parasitic capacitances of the gate signal lines 17 etc. and the anode electrodes 40. In order to reduce the parasitic capacitances, the insulation film (planarizing film) 34 is formed to have a thickness of 0.4 μm or larger. However, a thin insulation film 34 increases connection errors at the connection parts 37. For this reason, the insulation film 34 is configured or formed to have a thickness of 2.0 μm or smaller.

[0140] An insulation film 34 having a thickness of 0.4 μm or smaller causes an inter-layer insulation error, reducing the yield. An insulation film 34 having a thickness of 2.0 μm or larger makes it difficult to form contact connection parts, which causes insufficient contact, reducing the yield.

[0141] As the anode electrodes 40 of the pixels 16, transparent electrodes made of ITO, IGZO, IZO, TAOS, or the like can be used.

[0142] The parasitic capacitances occurring between the anode electrodes 40 and the gate signal lines 17 affect rise and fall times of the gate signal lines 17. The gate signal lines 17 for which a fast response is required is driven by the gate driver ICs 12 connected from outside. An anode voltage, a cathode voltage, etc. are supplied from rings (not illustrated) reinforced using reinforcement lines (not illustrated) of the COF 22. Accordingly, falls of voltages such as the anode voltages are small irrespective of the positions in the display screen.

[0143] A light scattering film 38 contributes to increase in light emitted from the panel. Light generated from one of the EL films 41 of the EL elements enters the panel board 31 (Trajectory a) and emitted from the panel board 31. However, when the light is incident on the light emission surface of the panel board 31 with a light incident angle larger than a critical angle, the incident light is reflected and returns to the EL film 41 (a trajectory b).

[0144] The light scattering film 38 is preferably formed to have a film thickness ranging from 0.1 (μm) to 1.5 (μm) inclusive, depending on a light diffusion performance.

[0145] It is to be noted that a circularly polarizing plate (circularly polarizing film) 32 is arranged on the light emission surface of the panel board 31. An integrated one of a polarizing plate and a phase film is referred to as a circularly polarizing plate (circularly polarizing film).

[0146] In a conventional EL display panel, the light having Trajectory b is diffused on the EL display panel and is absorbed therein. Accordingly, the light having Trajectory b is absorbed therein, and is not emitted from the panel to outside.

[0147] On the EL display panel according to the present disclosure, the light having Trajectory b is diffused on the light scattering film 38, and the trajectory of the light changes. As the result of the change in the trajectory, the light whose angle is reduced at or below the critical angle on the light emission surface of the panel is emitted from the panel (Trajectory c).

[0148] In this way, the trajectory of the light reflected on the boundary face of the panel is changed to be emitted from the panel to outside. Accordingly, the EL display panel has a high light utilization rate, and realizes a high luminance display.

[0149] Although the light scattering film 38 is formed above the insulation film 34 in the above non-limiting example, the light scattering film 38 may be formed in a layer below the insulation film 34.

[0150] In the peripheral parts of the color filters 33, a black matrix (BM) may be formed. Preferably, the black matrix (BM) is configured with a light absorbing film having a light absorbing property. This is because halation light in the panel can be reduced.

[0151] Examples of materials for use as a light absorbing film includes a material obtained by including carbon in an organic material such as acrylic resin, a material obtained by dispersing a black dye or a pigment in an organic resin, and a material such as a color filter obtained by dyeing using gelatin or casein using a block acid dye.

[0152] Alternatively, a material obtained using a fluoran dye representing a black color may be used, or a black color obtained by mixing a green dye and a red dye can also be used. Other examples include a PrMnO_3 film formed by sputtering, a phthalocyanine film formed by plasma polymerization.

[0153] Ribs (banks) 39 are formed in the peripheral parts of the anode electrodes 40. Ribs (banks) are also used as ribs (banks) 39 for use in mask deposition for ELs. The ribs (banks) 39 are used as contact parts of deposition masks to form EL films 41 (41R, 41G, 41B).

[0154] On the EL films 41, cathode electrodes 43 made of a metal material is formed. Examples of materials for use as the cathode electrodes 43 include silver (Ag), aluminum (Al), magnesium (Mg), calcium (Ca), or an alloy containing one or more of these metals. An example is a composition of Mg and Ag. In addition, it is also possible to use transparent electrodes made of ITO, IGZO, IZO, TAOS, or the like, depending on the structure of each EL element 15.

[0155] Needless to say, the above embodiments are also applicable to other embodiments in the present disclosure. In addition, the above embodiments can of course be combined with other embodiments.

[0156] As illustrated in FIG. 1, in the EL display of the "top light extraction", EL films 41 are formed, and on the EL films 41, a magnesium and silver (Mg and Ag) films to be cathodes (or anodes) are formed to have a film thickness ranging from

20 angstrom to 300 angstrom inclusive. In addition, it is preferable that transparent electrodes made of ITO or the like is formed on the Mg and Ag films as necessary in order for resistance reduction.

[0157] In addition, in the EL display of “top light extraction”, a low resistance line **44** made of a metal thin film in a layer above or below the cathode electrodes. Examples of compositions for use as the low resistance line **44** are the same as in a black matrix (BM) of a liquid crystal display panel. For example, chromium (Cr), aluminium (Al), titanium (Ti), and copper (Cu) may be used. Other examples include a three layer configuration of Ti, Cu, and Ti, and a three layer composition of Ti, Al, and Ti. Alternatively, an alloy of metal materials may be formed. Needless to say, the configurations, methods, and other details are also applicable to rings (not illustrated).

[0158] A thicker BM film is easy to have a reduced resistance and preferable. However, considering an unevenness problem, the film thickness thereof is set to be a range from 200 (nm) to 800 (nm) inclusive. The BM **44** is formed corresponding to the position of pixels **16** and the anode electrodes **40**. In other words, the BM **44** is mainly formed between pixel electrodes.

[0159] It is to be noted that a BM **44** may be formed for each of groups of R, G, B, and (W) pixels, or for each of a plurality of groups of R, G, B, and (W) pixels. The BM **44** may be formed on the layer above the gate driver ICs **12**. This is because the BM **44** functions as a light blocking film, to prevent operation errors of the gate driver ICs **12**.

[0160] Although the BM **44** has been described above, the BM **44** is different from an BM in LCD because there is no need to form an BM in an organic EL. A low resistance line (BM) **44** does not always need to be formed on a layer above optically transparent electrodes, and may be formed on a layer below optically transparent electrodes. Alternatively, a low resistance line (BM) **44** may be stacked with cathode electrodes and anode electrodes.

[0161] In addition, preferably, a sheet resistance value or a resistance value per unit length of an BM **44** varies corresponding to the part of a display screen **25**. A voltage decreases significantly at the center part or a part with many voltage supply points of the display screen **25**. For this reason, with increase in the distances from the voltage supply points, the BM **44** is made wider or the resistance value is reduced by thickening the BM **44**. The resistance value or the sheet resistance value of the BM **44** is reduced more significantly with decrease in the distance to the center part of the display screen **25** by widening or thickening the BM **44**.

[0162] An BM **44** can be formed thick when designing a panel. An BM **44** can be formed thick at the part corresponding to the center part of a display screen **25** by depositing the material of the BM **44** in a distribution. For example, a concentric circle like distribution of film thicknesses is generated.

[0163] A glass substrate **48** is bonded with a bonding layer **47**. The glass substrate **48** may be a thin sealing film. Alternatively, a glass substrate **48** may be configured as a sealing film.

[0164] When using a sealing film (thin sealing film) as a replacement for the glass substrate **48**, for example, a DLC film with diamond like carbon deposited thereon may be used. This film has a high moisture proof performance. This film is used as a sealing film.

[0165] Needless to say, the DLC film or the like may be directly deposited on the surfaces of the cathode electrodes **43**. Alternatively, a thin sealing film may be formed by stacking a thin resin film and a thin metal film.

[0166] FIG. **3** is a diagram for explaining an EL display according to the present disclosure. In a pixel **16a** in FIG. **3**, the source terminal of a switch transistor **11d** is connected to the drain terminal of a P-channel driver transistor **11a**, and the anode terminal of an EL element **15** is connected to the drain terminal of the switch transistor **11d**.

[0167] A cathode voltage V_{ss} is applied to the cathode terminal of the EL element **15**. An anode voltage V_{dd} is applied to the source terminal of the driver transistor **11a**. There is a relationship of the anode voltage $V_{dd} >$ the cathode voltage V_{ss} .

[0168] Here, the anode voltage is variable based on a maximum amplitude of a video signal to be output by a source driver IC **14**.

[0169] In addition, by turning on or off the switch transistor **11d**, a duty drive is performed.

[0170] When an on voltage is applied to a gate signal line **17b**, the switch transistor **11d** is turned on, and a current for light emission is supplied from the driver transistor **11a** to the EL element **15**. The EL element **15** emits light based on the magnitude of the current for light emission. The magnitude of the current for light emission is determined by applying a video signal applied to a source signal line **18** to the pixel **16a** using the switch transistor **11b**.

[0171] A first terminal of a capacitor **19a** is connected to the gate terminal of the driver transistor **11a**, and the first terminal of the capacitor **19a** is connected to the drain terminal of the switch transistor **11b**. The source terminal of the switch transistor **11b** is connected to the source signal line **18**. The applied on voltage of the gate signal line **17a** turns on the switch transistor **11a**, and a video signal V_s (voltage, current) applied to the source signal line **18** is applied to the pixel **16a**.

[0172] The first terminal of the capacitor **19a** is connected to the drain terminal of the switch transistor **11b**, and the second terminal is connected to the anode electrode and receives an anode voltage V_{dd} .

[0173] Although the second terminal of the capacitor **19a** is connected to the anode electrode **40** and receives the anode voltage V_{dd} , this is a non-limiting example. For example, another arbitrary direct voltage is applied thereto.

[0174] Although the source terminal of the driver transistor **11a** is connected to the anode electrode **40** and receives the anode voltage V_{dd} , this is a non-limiting example. For example, another arbitrary direct voltage is applied thereto. In other words, the second terminal of the capacitor **19a** and the source terminal of the driver transistor **11a** may be connected to terminals having different potentials.

[0175] A gate driver IC **12a** and a gate driver IC **12b** are connected to the gate signal line **17a** which drives the switch transistor **11b** for applying the pixel **16a** with a video signal V_s . As an example, the gate driver IC **12a** is arranged left of the display screen **25**, and the gate driver IC **12b** is arranged right of the display screen **25** (refer to FIG. **24** described later).

[0176] As illustrated in FIG. **3**, in each of the gate driver ICs **12** (**12a**, **12b**), shift registers **51** (**51a**, **51b**) which specify a gate signal line to which an on voltage is applied and an output buffer **52** which drives the gate signal line **17** (by supplying an on or off voltage and on or off current) are formed or arranged.

[0177] As illustrated in FIG. 4, output buffers 52 (52a, 52b) are configured to set or switch to any one of output performances as buffer performances. A switch is made by either of logic pins (Buf1 pin, Buf2 pin) arranged in gate driver ICs 12 (12a, 12b). For example, when the logic pins comprise three pins, the buffer performances which can be set comprise eight combinations as the cube-of-2 combinations.

[0178] Each group of one of shift registers 51 (51a, 51b) and the output buffer 52 (52a, 52b) is referred to as the gate signal output circuit 53 (53a, 53b).

[0179] The reason why two gate driver ICs 12 (12a, 12b) are arranged for a gate signal line 17a is described below.

[0180] The gate signal line 17a is connected to the switch transistor 11b. The switch transistor 11b is a transistor for writing a video signal to the pixel 16a, and the switch transistor 11b needs to perform a fast on and off operation (high slew rate operation). The gate signal line 17a performs the high slew rate operation by driving the two gate driver ICs 12 (12a, 12b).

[0181] Although the two gate driver ICs 12 are connected to the gate signal line 17 in the above embodiments, the present disclosure is not limited thereto. As illustrated in FIG. 3, the output buffer 52 is formed or arranged in each of the gate driver ICs (12a, 12b). Accordingly, this configuration is equivalent to a configuration in which two output buffers are connected to the gate signal line 17a. Each group of one of the shift register 51 (51a, 51b) and the output buffer 52 is referred to as a gate signal output circuit 53.

[0182] The gate signal line 17a drives the two gate driver ICs (12a, 12b), and thereby eliminating a luminance slope at right and left sides and the center of a display screen 25. Even when the load capacity of the gate signal line 17a is large, it is possible to turn on or off the switch transistor 11b effectively.

[0183] The gate driver IC 12a is connected to a gate signal line 17b. In other words, the gate signal line 17b is connected to the output buffer 52.

[0184] The gate signal line 17b is connected to a switch transistor 11d. The switch transistor 11d has a function for switching on or off a drive current to be flown from the driver transistor 11a to an EL element 15. The on and off operation for causing a current to flow to the EL element 15 can be performed only at a low slew rate.

[0185] Accordingly, the gate signal line 17b can obtain sufficient performances by driving the gate driver IC 12a (the output buffer 52).

[0186] In FIG. 3, the gate driver IC 12a and the gate driver IC 12b are of the same kind. In each of the gate driver ICs 12 (12a, 12b), shift registers 51 (51a, 51b) each corresponding in number to the gate signal lines 17 (17a, 17b) connected to the pixels 16 (16a, 16b) are formed or arranged. For example, in the pixel circuit configuration of the EL display illustrated in FIG. 3, the number of gate signal lines 17 (17a, 17b) of pixels 16 (16a, 16b) is two, and the number of shift registers 51 (51a, 51b) is two. In the pixel circuit configuration of the EL display illustrated in FIG. 44 described later, the number of the gate signal lines is four (gate signal lines 17a, 17b, 17c, and 17d), and thus the number of shift registers is four (shift registers 51a, 51b, 51c, and 51d).

[0187] In the embodiment in FIG. 3, two gate signal lines 17 which are the gate signal line 17a and the gate signal line 17b are formed in pixels 16 (16a, 16b). The shift register 51a of the gate driver IC 12a is arranged for the gate signal line 17a, and the shift register 51b of the gate driver IC 12b is

arranged for the gate signal line 17b. In other words, the two shift registers 51 (51a, 51b) are formed in each of the gate driver ICs 12 (12a, 12b).

[0188] In FIG. 3, the both ends of the gate signal line 17a are respectively connected to the gate driver ICs 12a and 12b (both-side drive). An end of the gate signal line 17b is connected to the gate driver IC 12a. The other end of the gate signal line 17b is open (one-side drive). The shift register 51a of the gate driver IC 12a is electrically connected to the gate signal line 17a at an odd pixel row, and the shift register 51b of the gate driver IC 12b is electrically connected to the gate signal line 17a at an even pixel row.

[0189] Accordingly, the speed of the shift clock of the gate driver IC 12b is the half of the speed of the shift clock of the gate driver IC 12a.

[0190] FIG. 4 is a diagram illustrating the gate driver IC according to another embodiment of the present disclosure. The Buf terminals (Buf1, Buf2) which are control terminals for setting buffer performances are arranged or formed between driver input terminals 73a to which serial connection lines are connected and driver output terminals 72.

[0191] SEL terminals which are control terminals for logic setting are arranged or formed between driver input terminals 73b which apply a voltage to the control terminals such as Clk to which serial connection lines are connected and the driver output terminals 72.

[0192] In this embodiment, each of the control terminals which set logics is arranged or formed between (i) corresponding one of the driver input terminals 73a to which the serial connection lines are connected or corresponding one of the driver input terminals 73b to which the serial connection lines are connected and (ii) the driver output terminals 72. However, this configuration is a non-limiting example. A COF 22g has only a single wiring layer, and thus it is impossible to form intersection parts in COF lines 74 (74a to 74e). Accordingly, the positions of terminals of the driver ICs can be represented as the connection positions in the COF 22g.

[0193] For example, in FIG. 4, when represented as the connection terminals of the COF 22g, each of Buf (Buf1, Buf2) terminals is connected to one of connection terminals 75c of the COF 22g, each of control terminals such as Clk2 is connected to one of connection terminals 75a, and each of COF lines 74e of the gate driver IC 12 is connected to one of the connection terminals 71. In addition, each of SEL (SEL1, SEL2) terminals is connected to one of connection terminals 75c, and each of control terminals such as Clk2 is connected to one of connection terminals 75b.

[0194] Accordingly, in the present disclosure, the connection terminals 75c of the COF 22g for the Buf (Buf1, Buf2) terminals which are logic setting terminals are arranged between or connected to the connection terminals 75a and the connection terminals 71. In addition, in the present disclosure, the SEL (SEL1, SEL2) terminals which are logic setting terminals are arranged between or connected to the connection terminals 75b and the connection terminals 71. In addition, the COF line 74a, a COF line 74c, and the COF line 74b (not illustrated) constitute a group of serial connection lines.

[0195] FIG. 5 is a diagram for explaining pixels of an EL display (EL display panel) according to another embodiment of the present disclosure.

[0196] In the EL display in FIG. 5, a pixel 16 is formed such that four gate signal lines 17 which are a gate signal line 17a, a gate signal line 17b, a gate signal line 17c, and a gate signal line 17d. A shift register 51a (not illustrated) of a gate driver

IC 12a is arranged for the gate signal line 17a, a shift register 51b (not illustrated) of the gate driver IC 12a is arranged for the gate signal line 17b, a shift register 51c (not illustrated) of the gate driver IC 12a is arranged for the gate signal line 17c, and a shift register 51d (not illustrated) of the gate driver IC 12a is arranged for the gate signal line 17d. In the pixel circuit configuration of the EL display in FIG. 3, the number of gate signal lines for the pixel 16 is two, the number of shift registers is two.

[0197] In the pixel 16 in FIG. 5, a first terminal of an N-channel switch transistor 11d is connected to either an electrode or a line of an anode voltage Vdd, and a second terminal thereof is connected to a first terminal of a driver transistor 11a. The gate terminal of the switch transistor 11d is connected to the gate signal line 17b.

[0198] In FIG. 5, although the transistors are N-channel transistors, this is a non-limiting example, and the transistors may be P-channel transistors. In addition, one or more P-channel transistors and one or more N-channel transistors may coexist.

[0199] A first terminal of a switch transistor 11e is connected to an electrode or a line to which a reset voltage Vref is applied, and a second terminal of the switch transistor 11e is connected to the gate terminal of the driver transistor 11a. The gate terminal of the switch transistor 11e is connected to the gate signal line 17c.

[0200] A first terminal of the switch transistor 11b which applies the pixel 16 with a video signal is connected to a source line 18, and a second terminal of the switch transistor 11b is connected to the gate terminal of the driver transistor 11a. The gate terminal of the switch transistor 11b is connected to the gate signal line 17a.

[0201] A first terminal of a switch transistor 11c is connected to an electrode or a line to which an initial voltage Vini is applied, and a second terminal of the switch transistor 11c is connected to a second terminal of the driver transistor 11a. The gate terminal of the switch transistor 11c is connected to the gate signal line 17d.

[0202] A first terminal of an EL element 15 is connected to a second terminal of the driver transistor 11a, and a second terminal of the EL element 15 is connected to an electrode or a line to which a cathode voltage Vss is applied.

[0203] A first terminal of a capacitor 19 is connected to the gate terminal of the driver transistor 11a, and a second terminal of the capacitor 19 is connected to a second terminal of the driver transistor 11a.

[0204] For at least one of the switch transistors 11b or a switch transistor 11e, a multi-gate (dual-gate or above) structure is employed, and a lightly doped drain (LDD) configuration is combined. With this configuration, an off-leak is controlled, an excellent contrast can be obtained, and offset cancelling can be performed. In addition, an excellent high luminance display and image display can be realized.

[0205] The gate signal line 17a and the gate signal line 17c are driven at both sides by the gate driver IC 12a and the gate driver IC 12b. In addition, the gate signal line 17c and the gate signal line 17d are driven at one side by the gate driver IC 12a.

[0206] In FIG. 5, a both-side drive is performed on the gate signal line 17c connected to the switch transistor 11b which applies a video signal to the pixel 16. In addition, a both-side drive is performed on the gate signal line 17a connected to the switch transistor 11d which performs an operation or control at the time of offset cancelling of the driver transistor 11a.

[0207] FIG. 6 is a schematic diagram for explaining a state in which a gate driver IC 12 is mounted on a flexible board (COF) 22g.

[0208] The following are connected or arranged to a gate signal output circuit 53a: a data input terminal (Dat1) which inputs data to a shift register (not illustrated); an enable input terminal (Enb1) which enables or disables output from the shift register (not illustrated) (an on voltage is output to a gate signal line, and an off voltage is output to the gate signal line); and a clock input terminal (Clk1) which inputs a clock for shifting data in the shift register (not illustrated).

[0209] The following are connected or arranged to the gate signal output circuit 53b: a data input terminal (Dat2) which inputs data to a shift register (not illustrated); an enable input terminal (Enb2) which enables or disables output from the shift register (not illustrated) (an on voltage is output to a gate signal line when the output is enabled, and an off voltage is output to the gate signal line when the output is disabled); and a clock input terminal (Clk2) which inputs a clock for shifting data in the shift register (not illustrated).

[0210] On the flexible board 22g, COF lines 74 (74a, 74b, 74c, 74d, and 74e) are formed. A signal or a voltage is applied to the gate driver IC 12 from the driver input terminals 73 (73a, 73b) via the COF lines 74a, 74b, and 74c.

[0211] As illustrated in FIG. 6, SEL (SEL1, SEL2) terminals which are control terminals are each connected to a gate driver IC 12 via one of connection terminals 75c. Voltage application terminals Voff (Voff1, Voff2) are each connected to a gate driver IC 12 via one of connection terminals 75b.

[0212] The SEL terminals and the voltage application terminals Voff (Voff1, Voff2) are arranged or formed at an output side of the gate driver IC 12.

[0213] The connection terminals 75c of logic setting terminals such as SEL (SEL1, SEL 2) terminals are arranged or formed between connection terminals 71 and driver input terminals (73b).

[0214] The connection terminals 75c receive predetermined voltages such as logic voltages from the logic terminals SEL1 and SEL2. One of the logic voltages is applied to an operation terminal 76 of the gate driver IC 12 via a line 74d (hereinafter referred to as a "terminal connection line") which connects a point inside the COF 22g and a connection terminal 71.

[0215] Signal output from the gate driver IC 12 are output from the connection terminals 71 via driver output terminals 72 and COF lines 74e. Gate signal lines 17 are connected to the connection terminals 71.

[0216] As illustrated in FIG. 7, at least one of the driver input terminals (73a, 73b) is provided at a point right and left of a long side of the chip of the gate driver IC 12. With this configuration, the chip is less affected by a voltage fall. Even when a connection error occurs at one of the driver input terminals 73 (73a, 73b), the operation by the gate driver IC 12 is not affected.

[0217] As illustrated in FIG. 7, the SEL terminals and the Voff terminals are arranged between Von input terminals (VonA, VonB) and the driver output terminals 72. Input stages for the control signals Dat1, Enb1, Clk1, Dat2, Enb2, Clk2 etc. are formed or arranged at two or more points of the gate driver IC 12. Preferably, the two points are arranged at positions which are line symmetrical to each other with respect to the center line of short sides of the gate driver IC 12.

[0218] At the input stages for the control signals such as Dat1, Enb1, Clk1, Dat2, Enb2, Clk2, input circuits such as

Schmidt circuit and a hysteresis circuit are formed. Each of gate signal output circuits 53 (53a, 53b) is configured to latch input signals. For example, in the Clk2, a clock input to a connection terminal 75a is applied to the driver input terminal 73a via a COF line 74a. The clock signal applied to the driver input terminal 73a is subjected to noise removal at the Schmidt circuit of the gate signal output circuit 53b, and latched by a latch circuit (not illustrated). The latched clock data is output to the driver input terminal 73b via a line (not illustrated) formed inside the gate signal output circuit 53a. The clock data Clk2 output from the driver input terminal 73b is output from the connection terminal 75b via a COF line 74c.

[0219] In FIG. 7, a COF line 74b is formed between the driver input terminal 73a and the driver input terminal 73b, this COF line 74b is for reinforcing data transmission. Accordingly, although the COF line 74b can be omitted, the COF line 74b when formed allows a user to stably transmit control data.

[0220] When a line connecting the driver input terminal 73a and the driver input terminal 73b is a power supply line such as a Von voltage line and a Voff voltage line, the COF line 74b functions as a bypass line. The COF line 74b reduces an impedance of a power supply line, and increases stable supply of power.

[0221] As illustrated in each of FIGS. 8A, 8B, and 9, even when a line connected to a driver input terminal 73a and a driver input terminal 73b is a power supply line that is a Von voltage line or a Voff voltage line, internal lines 262 (262a, 262b, 262c) may be added. In other words, a COF line 74b and the internal lines 262 (262a, 262b, 262c) may wire-connect the driver input terminal 73a and the driver input terminal 73b. Furthermore, a plurality of input terminals for on voltages (VonA, VonB) may be arranged or formed.

[0222] As illustrated in each of FIGS. 8A and 8B, each of bi-directional buffers 271 (271a, 271b) is arranged in a point on each of the internal lines 262 (262a, 262c). The internal line 262a is electrically connected to the driver input terminal 73a and the bi-directional buffer 271a. The internal line 262b is electrically connected to the bi-directional buffer 271a and the bi-directional buffer 271b. The internal line 262c is electrically connected to the driver input terminal 73b and the bi-directional buffer 271b. Each of the driver input terminal 73a and the driver input terminal 73b may be connected to any one of a terminal for data Dat, a terminal for a clock Clk, a terminal for an enable signal Enb. In any of the connections, the driver input terminal 73a and the driver input terminal 73b may be an input terminal or an output terminal, or the driver input terminal 73b and the driver input terminal 73a may be an input terminal and an output terminal.

[0223] Control signals such as the clock Clk, data Dat, enable Enb are transmitted via the internal line 262 (262a to 262c). COF lines 74c transmit an on voltage Von, an off voltage Voff, a logic voltage Vcc, and a ground voltage Vgg.

[0224] Since the internal lines 262 (262a to 262c) transmit the control signals such as the clock Clk, data Dat, enable Enb, the COF 22g does not require formation or arrangement of the COF lines 74c for control signal lines. For this reason, Distance A and Distance B in FIG. 50 can be shortened. As a result, the size of the COF 22g can be reduced, which achieves cost reduction.

[0225] The lines for transmitting the control signals such as the clock Clk, data Dat, enable Enb are configured to arrange the bi-directional buffer 271 (271a, 271b) in the internal lines

262 (262a to 262c), and the bi-directional buffer 271 supports hysteresis input. Accordingly, a waveform is adjusted to adjust a delay time. For this reason, synchronous control of gate signal lines 17 on a display screen is easy to realize. Since synchronization with a delay circuit 485 in FIG. 13 is easy to realize, the image quality can be enhanced.

[0226] FIG. 9 illustrates a configuration in which a plurality of driver input terminals 73 (73a2, 73b2) are arranged for each of driver input terminals 73 (73a1, 73b1), and these driver input terminals are wire-connected through internal lines 262. For example, two driver input terminals S1a (73b1, 73b2) are formed, and the driver input terminal S1a (73b1) and the driver terminal S1a (73b2) are electrically connected through a corresponding one of the internal lines 262. Similarly, for example, two driver input terminals S1a (73a1, 73a2) are formed, and the driver input terminal S1a (73a1) and the driver terminal S1a (73a2) are electrically connected through a corresponding one of the internal lines 262.

[0227] In addition, driver input terminals S3b and S2b are electrically connected through a COF line 74f1. The driver input terminals S2b and S3b are electrically connected through a COF line 74f2.

[0228] With the configuration, a control signal can be supplied to the plurality of driver input terminals S2b and S3b by a COF line 74a1 which supplies a control signal to a gate driver IC 12. In addition, a voltage can be supplied to the driver input terminals S2b and S3b by a COF line 74c1 which supplies a control signal to a gate driver IC 12.

[0229] In an EL display illustrated in FIG. 9, a gate signal output circuit 53a and a gate signal output circuit 53b are formed or arranged in the gate driver IC 12. The following are connected to each of the gate signal output circuits 53 (53a, 53b): control terminals (SEL1, SEL2); and two off voltage input terminals (Voff1, Voff2); and a single on voltage input terminal (VonA for the gate signal output circuit 53a, and VonB for the gate signal output circuit 53b). The SEL terminals (SEL1, SEL2) are pulled down. The SEL terminals are logic terminals for switching between a three-value drive of gate voltages and a two-value drive of gate voltages. The three-value drive of gate voltages and the two-value drive of gate voltages are described later with reference to FIGS. 21, 22A, 22B, 20A, 20B, 28, 29, etc.

[0230] An on voltage and an off voltage to be applied to gate signal lines 17 are output from driver output terminals 72 of the gate driver IC 12. The driver output terminals 72 and connection terminals 71 are electrically connected through COF lines 74e formed in a COF 22g.

[0231] Lines which connect between two or more connection terminals 75 (75a, 75b) such as a clock CLK terminal, a data Dat terminal, on a Von voltage terminal are connected to a driver input terminal 73b and a driver input terminal 73a (the lines are hereinafter referred to as "serial connection lines", and are for example, in FIG. 50 later referred to, a line from a COF line 74a via a COF line 74b to a COF line 74c, or a line from a panel line 91a via a COF line 74a via a COF line 74b via a COF line 74c to a panel line 91b).

[0232] The driver input terminal 73a and the connection terminal 75a are electrically connected through the COF line 74a formed in the COF 22g. In addition, the driver input terminal 73b and a connection terminal 75b are electrically connected through the COF line 74c formed in a COF 22g.

[0233] As illustrated in each of FIG. 7 and FIG. 50, the driver input terminals 73a and the driver input terminals 73b

are electrically connected through the COF line **74b** (in FIG. 7) or **74c** (in FIG. 50) formed in the COF **22g**.

[0234] Operation terminals **76** of a gate driver IC **12** are arranged or formed between (i) driver output terminals **72** and driver input terminals **73a**, or (ii) the driver output terminals **72** and driver input terminals **73b**. Alternatively, operation terminals **76** are arranged or formed between the both, that is, between (i) driver output terminals **72** and driver input terminals **73a**, or (ii) the driver output terminals **72** and driver input terminals **73b**.

[0235] The following are formed in the COF **22g**: COF connection lines (**74a**, **74b**, **74c**) to be serial connection lines are formed; and a COF connection line **74e** for transmitting an on voltage (V_{on}) and off voltages (V_{off1} , V_{off2}) from the gate driver IC **12** to the gate signal line **17**.

[0236] A COF connection line **74d** is arranged or formed either between a COF connection line **74e** and a COF connection line **74c**, or between a COF connection line **74a** and the COF connection line **74e**. Thus, the COF connection line **74d** does not have any intersection parts with the COF connection line **74e**, the COF connection line **74a**, the COF connection line **74b**, and the COF connection line **74c**. Accordingly, even when the COF **22g** is wired at one side, the COF connection line **74d** can be easily formed.

[0237] Furthermore, it is easy to layout a pattern on the COF connection line **74d** from the panel side (on which the panel lines **91** (**91a**, **91b**) are formed) so that a voltage can be applied to the COF lines **74d**.

[0238] As described above, the terminals (such as the SEL terminals) connected to the COF connection line **74d** do not need to be connected in serial connection. For this reason, it is possible to reduce the number of COF lines **74a**, **74b**, and **74c** to be the serial connection lines.

[0239] With the configuration disclosed above, it is possible to shorten or reduce Distance B, Distance A, Distance C, and Distance D explained with reference to FIG. 50. Accordingly, it is possible to reduce the size of the COF **22g** and also reduce the size of the gate driver IC **12**, and to thereby reduce the cost of the EL display.

[0240] In FIG. 13, R denotes a resistor. The logic of SELs is a pull-down state. Needless to say, the resistor R may be formed inside the gate driver IC **12**.

[0241] As illustrated in FIG. 10, control signal lines for input to a gate driver IC **12** and COF lines **74** (**74a** to **74e**) as voltage lines are pattern-formed in serial connection. In other words, they are formed to be serial connection lines.

[0242] On a panel board **31**, panel lines **91** (**91a** (**91a1**), **91b**(**91b1**)) are formed or patterned. The panel lines **91** are power supply lines such as an on voltage V_{on} , off voltages V_{off} , an anode voltage V_{dd} , and a cathode voltage V_{ss} , and control lines such as Clk, Enb, etc.

[0243] The V_{on} denotes an on voltage to be applied to the gate signal line **17**, V_{off} denotes an off voltage to be applied to the gate signal line **17**, V_{cc} is a ground voltage V_{gg} of the power supply of a logic circuit to be used in the gate driver IC **12**, and V_{gg} is a ground voltage of the logic terminal.

[0244] The panel line **91a1** located innermost of the panel line **91a** and the panel line **91b1** located innermost of the panel line **91b** are lines to which a voltage V_{cc} or a voltage V_{gg} is applied. The voltage V_{cc} or the voltage V_{gg} means a setting voltage of the logic terminal in a broad sense.

[0245] However, a voltage to be applied to the panel lines **91a1** and **91a2** may be a voltage V_{on} or a voltage V_{off} . In other words, the voltage to be applied may be a constant voltage

fixed in a certain period. The voltage V_{on} or the voltage V_{off} is subject to a level shift process or a level down process at a level transform circuit in the driver IC **12**, and the resulting voltage can be used as a voltage level signal for logic setting of the gate driver IC **12**.

[0246] An input control line **261a** branches from the panel line **91a1**. The input control line **261a** is connected to a connection terminal **75c** of a COF **22g**. The connection terminal **75c** is a terminal to which a control voltage at a logic level is to be applied. The control voltage at the logic level is a signal voltage for logic setting. For example, a voltage at or above a first predetermined voltage is assumed to be Level H of the logic, and a voltage below the first predetermined voltage is assumed to be Level L. An operation terminal **76** and the connection terminal **75c** of the gate driver IC **12** are electrically connected to the COF connection line **74d**.

[0247] An input control line **261b** branches from the panel line **91b1**. The input control line **261b** is connected to the connection terminal **75c** of the COF **22g**. The operation terminal **76** and the connection terminal **75c** of the gate driver IC **12** are electrically connected to the COF connection line **74d**. The operation terminal **76** is arranged between the connection terminal **71** of the gate signal line **17** and a driver input terminal **73a** of the gate driver IC **12**.

[0248] The panel line **91a** is connected to the COF line **74a** of the COF **22g** through a connection terminal **75a** at the upper part of the drawing sheet. The COF line **74a** is connected to the driver input terminal **73a**. The driver input terminal **73a** and a driver input terminal **73b** are electrically connected through the COF line **74b**.

[0249] As described above, on the gate driver IC **12**, a plurality of driver input terminals **73** (**73a**, **73b**) are arranged or formed for a voltage of one kind and a control signal of one kind.

[0250] The driver input terminal **73b** and the connection terminal **75b** are electrically connected through the COF line **74c**. The connection terminal **75b** is connected to the panel line **91b**.

[0251] As described above, they are formed or arranged in serial connection to the panel line **91a**, the connection terminal **75a**, the COF line **74a**, the driver input terminal **73a**, the COF line **74b**, the driver input terminal **73b**, the COF line **74c**, the connection terminal **75b**, and the panel line **91b**. In other words, they are connected by the serial connection lines.

[0252] FIG. 11 is a diagram illustrating a state in which a plurality of flexible boards **22g** (**22g1**, **22g2**) are mounted on a panel board **31**. The flexible board **22g1** and the flexible board **22g2** are electrically connected through a panel line **91b**. The panel line **91b** is formed at the same time when gate signal lines **17** and source lines **18** are formed. In addition, they are made of a material identical or similar to the materials of the gate signal lines **17** and the source signal lines **18**.

[0253] A voltage and a control signal from a driver circuit (not illustrated) are applied from a voltage and signal input unit **101** to a panel substrate **31**, and are then applied to the flexible board **22g1** through a panel line **91a**, and are then applied to a driver input terminal **73a** of a gate driver IC **12a**. The voltage and signal input unit **101** is connected to a source print board **23**. The voltage and the signal are supplied from the source print board **23** to the COF **22g** through the voltage and signal input unit **101**.

[0254] The voltage and the control signal from the flexible board **22g1** are applied to the flexible board (COF) **22g2** through the panel line **91b**, and are then applied to a gate

driver IC 12b. The voltage and the control signal from the flexible board (COF) 22g2 are applied to a next flexible board (COF) 22g3 (not illustrated) through a panel line 91c. As described above, the voltage and the control signal are connected in serial connection to a plurality of flexible boards (COF) 22g through the panel line 91b.

[0255] FIG. 12 is a diagram illustrating a COF 22g1 on which a gate driver C12 disclosed here is mounted. A panel line 91a is connected to a COF line 74a through a connection terminal 75a. The COF line 74a is connected to a driver input terminal 73b, and a driver input terminal 73a and the driver input terminal 73b are electrically connected through a COF line 74c. The driver input terminal 73b and a connection terminal 75b are electrically connected through a COF line 74b. A panel line 91b is connected to the connection terminal 75b, and the panel line 91b is electrically connected to a connection terminal 75c of a COF 22g2 located next.

[0256] A voltage Vcc (a logic voltage of a driver IC) is applied to input control lines 261. In other words, a logic voltage (normally, a voltage Vcc or Vgg) to be applied to the connection terminal 75c is applied to the panel line 91a. The connection terminal 75c and an operation terminal 76 are electrically connected through a connection line 74d. A logic voltage is applied to lines (91a1, 91b1) located innermost of the panel line 91. The logic voltage is applied to an operation terminal 76 connected to the COF connection line 74d.

[0257] As illustrated in FIG. 12, SEL terminals (SEL1, SEL2, SEL3, SEL4) are connected to the COF line 74. The SEL terminals are terminals for setting a selection between a two-value drive of gate voltages and a three-value drive of gate voltages of the gate driver IC 12. The SEL terminals are pulled down to Vgg by a resistor R formed in the gate driver IC 12.

[0258] In a state where one or more of the SEL terminals is open (no voltage is applied thereto), the logic is L. In the case of L, a two-value drive of gate voltages (FIG. 20A) is set. The logic is H in a state where a voltage Vcc is applied to one or more of the SEL terminals. In the case of H, a three-value drive of gate voltages (FIG. 20B) is set.

[0259] More specifically, an array pattern is laid out so that a voltage is applied to operation terminals 76 through the input control lines 261, or a pattern (not wire-connected) is laid out so that the operation terminals 76 is open without applying a voltage to the operation terminals 76. With this configuration, it is possible to determine logic levels of the SEL terminals (SEL1 to SEL4). Based on these logic levels, it is possible to set or determine which one of a two-value drive of gate voltages or a three-value drive of gate voltages is performed by each of gate signal output circuits 53 (53a, 53b, 53c, 53d).

[0260] As illustrated in each of FIGS. 8A, 8B, and 12, inbetween the driver input terminal 73a and the driver input terminal 73b, the following exist: parts connected through the COF line 74c formed on the COF 22g; and parts connected through the internal lines 262 of the driver IC 12.

[0261] The internal lines 262 constitute an internal line pattern of the gate driver IC 12. It electrically connects the driver input terminal 73a and the driver input terminal 73b.

[0262] FIG. 13 is a diagram illustrating a gate driver IC 12 in an EL display (EL display panel) according to the present disclosure. Four gate signal output circuits 53 (53a, 53b, 53c, 53d) are formed or arranged in the gate driver IC 12.

[0263] In each of the gate signal output circuits 53 (53a, 53b, 53c, 53d), the following are arranged or formed: an input

(application) terminal of an on voltage (Von); a data input (Dat) terminal; an enable (Enb) terminal; and a clock (Clk) terminal. A terminal (UD terminal) which inverses a vertical scanning direction is shared by these four gate signal output circuits 53.

[0264] These SEL terminals are arranged corresponding to the respective gate signal output circuits 53 (53a, 53b, 53c, 53d). Each of the SEL terminals is a terminal for setting or operating a two-value drive of gate voltages and a three-value drive of gate voltages. In a broad sense, the SEL terminals are terminals for switching or controlling drive modes of the gate signal output circuits 53 (53a, 53b, 53c, 53d). Accordingly, the drive methods are not limited to the two-value drive of gate voltages and the three-value drive of gate voltages. For example, each of the SEL terminals may be a terminal for setting a selection of one of the four value voltages which are a voltage Von1, a voltage Von2, a voltage Voff1, and a voltage Voff2.

[0265] The gate signal output circuit 53a is set to the three-value drive of gate voltages by setting the SEL1 terminal to Logic "H", and the gate signal output circuit 53b is set to the three-value drive of gate voltages by setting the SEL2 terminal to Logic "H". The gate signal output circuit 53c is set to the three-value drive of gate voltages by setting a SEL3 terminal to Logic "H", and the gate signal output circuit 53d is set to the three-value drive of gate voltages by setting a SEL4 terminal to Logic "H". It is to be noted that the settings of Logic "H" and "L" may be inverted.

[0266] FIG. 13 illustrates an alternative configuration in which two SEL terminals are arranged instead, logic signals applied to the two SEL terminals are decoded, and one of the four gate signal output circuits 53 (53a, 53b, 53c, 53d) is selected. For example, assuming that these two SEL terminals are a SEL0 terminal and a SEL1 terminal, in the case of (SEL0, SEL1)=(L, L), the gate signal output circuit 53a is set to the three-value drive of gate voltages, and the gate signal output circuits 53b, 53c, and 53d are set to the two-value drive of gate voltages. Alternatively, assuming that these two SEL terminals are a SEL0 terminal and a SEL1 terminal, in the case of (SEL0, SEL1)=(L, H), the gate signal output circuit 53b is set to the three-value drive of gate voltages, and the gate signal output circuits 53a, 53c, and 53d are set to the two-value drive of gate voltages. Alternatively, assuming that these two SEL terminals are a SEL0 terminal and a SEL1 terminal, in the case of (SEL0, SEL1)=(H, L), the gate signal output circuit 53c is set to the three-value drive of gate voltages, and the gate signal output circuits 53a, 53b, and 53d are set to the two-value drive of gate voltages. Alternatively, assuming that these two SEL terminals are a SEL0 terminal and a SEL1 terminal, in the case of (SEL0, SEL1)=(H, H), the gate signal output circuit 53d is set to the three-value drive of gate voltages, and the gate signal output circuits 53a, 53b, and 53c are set to the two-value drive of gate voltages. With this configuration, it is possible to reduce the number of SEL terminals.

[0267] The one for which the three-value drive of gate voltages is performed is 17a gate signal line a connected to a transistor for writing a video signal to a pixel 16. Even when a plurality of gate signal lines are formed or arranged in the pixel 16, the gate signal line connected to the transistor for applying the video signal is identified solely as a gate signal line 17a. In other words, even when a plurality of gate signal driver circuits are formed in the gate driver IC 12, one of them can be set to be subject to the three-value drive of gate volt-

ages, and the other gate signal driver circuit may be subject to the two-value drive of gate voltages.

[0268] For example, when eight gate signal driver circuits are arranged or formed on the gate driver IC 12, the number of SEL terminals may be three, and a decoder (3-8 decoder) for selecting one of eight 3-bit gate signal line driver circuits may be configured.

[0269] As described above, in the present disclosure, the SEL terminals make it possible to switch between the two-value drive of gate voltages and the three-value drive of gate voltages independently or individually for the gate signal output circuits 53 (53a, 53b, 53c, 53d) corresponding respectively to the gate signal lines.

[0270] In the present disclosure, the gate signal line 17 connected to the transistor for writing a video signal is driven by a both-side drive (performed by two gate driver ICs 12 arranged right and left of a display screen 25). The other gate signal lines for which fast slew rate is not required is driven by a one-side drive (performed by one of the gate driver ICs 12 arranged right and left of the display screen 25).

[0271] In each of the EL display illustrated in FIGS. 8A, 8B, and 12, the operation terminals 76 are arranged or formed on or near a side (a long side of the driver IC) on which driver output terminals 72 are formed. However, the present disclosure is not limited thereto. For example, as illustrated in FIGS. 8A and 8b, the operation terminals 76 may be formed on or near a short side of the gate driver IC 12. Alternatively, the operation terminals 76 may be formed on a side (a long side of the driver IC) on which the driver input terminals 73a and 73b are formed. The operation terminals 76 may be arranged between the driver output terminals 72 and the driver input terminals 73 (73a, 73b). By arranging the operation terminals 76 between the driver output terminals 72 and the driver input terminals 73 (73a, 73b), logic setting can be performed easily through the panel lines 91a1 and 91b1 or the input control lines 261 branching from the panel lines 91a1 and 91b1.

[0272] The EL display according to this embodiment connects control signal lines for logic control, etc. from the panel side (on which the panel line 91 is formed) to the operation terminals 76. With this configuration, the number of COF lines 74 (74a, 74b, 74c) is reduced. In a conventional EL display, all of control signal lines and power supply lines need to be formed in serial connection. Thus, as illustrated in FIG. 50, there is a problem that Distance A, Distance B, and Distance D are long. On the other hand, in the EL display according to this embodiment, the control signal lines connected to the operation terminals 76 do not form COF lines 74 (74a, 74b, 74c). For this reason, the number of COF lines 74 can be reduced, Distance A, Distance B, and Distance D are shortened, and the size of the COF and the size of the driver IC can be reduced.

[0273] In addition, input control lines 261 are formed to branch from lines to which predetermined voltages (e.g. a logic voltage Vcc, a ground voltage Vgg) are applied from the panel lines 91 (91a, 91b). In a configuration according to a wiring layout design for forming an array pattern, voltages corresponding to logics to be set are applied to the operation terminals 76. With this configuration, Distance C for forming the panel lines 91 (91a, 91b) in FIG. 50 is shortened. For this reason, the frame of the panel can be made smaller.

[0274] Although the above descriptions have been given of the gate driver IC 12 and the COF 22g, needless to say, the same descriptions can also apply to the source driver IC 14 and the COF 22s.

[0275] Of course, the above embodiments are also applicable to other embodiments in the present disclosure. In addition, the above embodiments can, not to mention, be combined with other embodiments.

[0276] FIG. 13 is a diagram illustrating a gate driver IC according to another embodiment of the present disclosure. A UD terminal (for setting a scanning direction of a shift register 51) that is a control terminal for logic setting is arranged or formed between driver input terminals 73a and driver output terminals 72, to which serial connection lines are connected.

[0277] SEL terminals (for setting a two-value drive of gate voltages and a three-value drive of gate voltages of a gate signal output circuit 53) that are control terminals for logic setting are arranged or formed between driver input terminals 73b and the driver output terminals 72, to which serial connection lines are connected.

[0278] FIG. 15 is a diagram illustrating a gate driver IC according to another embodiment of the present disclosure. SEL terminals which are control terminals for logic setting are arranged or formed between driver input terminals 73a and driver output terminals 72 to which serial connection lines are connected.

[0279] A UD terminal that is a control terminal for logic setting is arranged or formed between driver input terminals 73b apply voltages (a voltage Von, a voltage Voff) and the driver output terminals 72 to which serial connection lines are connected.

[0280] FIG. 15 illustrates a configuration in which the respective gate signal output circuits 53 (53a, 53b, 53c, 53d) are provided with respectively different voltages of Voff1 (Voff1a to voff1d) and Voff2 (Voff2a to voff2d). The voltage Voff1a and a voltage Voff2a are supplied to the gate signal output circuit 53a. Accordingly, when the gate signal output circuit 53a performs a three-value drive of gate voltages, a voltage VonA, a voltage Voff1a, and the voltage Voff2a are output.

[0281] Likewise, when the gate signal output circuit 53b performs a three-value drive of gate voltages, a voltage VonB, a voltage Voff1b, and a voltage Voff2b are output. When the gate signal output circuit 53c performs a three-value drive of gate voltages, a voltage VonC, a voltage Voff1c, and a voltage Voff2c are output. When the gate signal output circuit 53d performs a three-value drive of gate voltages, a voltage VonD, a voltage Voff1d, and a voltage Voff2d are output.

[0282] The other details are the same as in FIG. 13 and the above embodiments, and thus the same descriptions are not repeated.

[0283] FIG. 16 is a diagram illustrating a gate driver IC according to another embodiment of the present disclosure. SEL terminals for logic setting or operation setting are connected to connection terminals 75c, and gate signal lines 17 are connected to connection terminals 71. A UD terminal for logic setting or operation setting is connected to connection terminal 75c. Voltages Voff (Voff1, voff2) are each applied to a connection terminal 75a or 75b.

[0284] In addition, a COF line 74a, a COF line 74c (not illustrated), and a COF line 74b constitute a group of serial connection lines. The connection terminal 75a of one of the SEL terminals for logic setting or operation setting is connected or arranged between the connection terminals 71 of the gate signal lines 17 and the connection terminals 75a. The connection terminal 75c of the UD terminal for logic setting or operation setting is connected or arranged between the connection terminals 71 of the gate signal lines 17 and the

connection terminals **75b**. When a logic voltage is applied to the operation terminals **76**, or a pull-up or a pull-down is performed in the gate driver IC **C12**, no voltage is applied to the operation terminals **76** so as to keep the operation terminals **76** open.

[0285] FIG. 17 illustrates a configuration in which an input control line **261a** branches from a panel line **91a1** of a panel line **91a**. It is assumed that, for example, a logic voltage V_{cc} is applied to the input control line **261a** as a branch. The input control line **261a** is connected to operation terminals **76a**.

[0286] An input control line **261b** branches from a panel line **91a2** of the panel line **91a**. It is assumed that, for example, a logic voltage V_{gg} is applied to the input control line **261b** as a branch. The input control line **261b** is connected to operation terminals **76b**.

[0287] With this configuration, the operation terminals **76b** to which the ground voltage V_{gg} is applied have a logic level of L. The operation terminals **76a** to which the logic voltage V_{cc} is applied have a logic level of H.

[0288] The operation terminals **76** (**76a**, **76b**) are terminals for defining or setting modes, operations, and actions of gate signal output circuits **53** (**53a** to **53d**) in a gate driver IC **12**. The logic levels (H, L) applied to the operation terminals **76** set actions of the gate driver IC **12**.

[0289] In the configuration of FIG. 17, the input control line **261a** and the input control line **261b** are lines formed on a panel. In addition, there are intersection parts between the input control line **261a** and the input control line **261b**. However, the intersection parts between the input control line **261a** and the input control line **261b** are few, and thus do not reduce a yield of panels. The other details are the same as in the above embodiments of the present disclosure, and thus the same descriptions are not repeated.

[0290] In FIG. 18, a voltage V_{off2} is applied to a driver input terminal **73a**. A voltage V_{off1} is applied to a driver input terminal **73b**, and a voltage V_{on1} is applied to a driver input terminal **73c**.

[0291] The voltage V_{on} applied to the driver input terminal **73c** is used as a voltage of Logic H. The voltage V_{off} applied to the driver input terminal **73b** is used as a voltage of Logic L.

[0292] The driver input terminal **73c** is connected to an internal line **262c**. The driver input terminal **73b** is connected to an internal line **262b**. The internal line **262c** becomes a voltage of Logic (logic level) H, and is output to terminals **H4** to **H1** of a gate driver IC **12**. An internal line **262b** becomes a voltage of Logic (logic level) L, and is output to terminals **L5** to **L1** of the gate driver IC **12**. Operation terminals **C8** to **C1** are the operation terminals **76**.

[0293] As a connection denoted as "A" in FIG. 18, by short-circuiting the terminal **L5** and the operation terminal **C8**, a logic level of L is applied to the operation terminal **C8**. Accordingly, a gate signal output circuit **53d** is set to an action corresponding to the logic level of the operation terminal **C8**.

[0294] Likewise, as a connection denoted as "B" in FIG. 18, by short-circuiting the terminal **H5** and the operation terminal **C7**, a logic level of H is applied to the operation terminal **C7**. Accordingly, the gate signal output circuit **53c** is set to an action corresponding to the logic level of the operation terminal **C7**.

[0295] As a connection denoted as "C" in FIG. 18, by short-circuiting the terminal **L5** and the operation terminal **C6**, a logic level of L is applied to the operation terminal **C6**.

Accordingly, a gate signal output circuit **53b** is set to an action corresponding to the logic level of the operation terminal **C6**.

[0296] As a connection denoted as "D" in FIG. 18, by short-circuiting the terminal **L1** and the operation terminal **C1**, a logic level of L is applied to the operation terminal **C1**. Accordingly, a gate signal output circuit **53a** is set to an action corresponding to the logic level of the operation terminal **C1**.

[0297] As described above, an EL display according to this embodiment is configured to perform a method for setting the logic levels of the operation terminals **76** through the internal lines **262** (**262b**, **262c**).

[0298] In other words, in each of the embodiments illustrated in FIGS. 12 and 17, it is possible to reduce the number of serial connection lines on the COF **22g** by forming the input control lines **261** on the panel. As a result, it is possible to reduce the size of the gate driver IC **12**, reduce the size of the COF **22g**, and reduce cost of the EL display (EL display panel).

[0299] As illustrated in each of FIGS. 8A, 8B, and 12, it is possible to reduce the number of serial connection lines by forming the internal lines **262** in the gate driver IC **12**. As a result, it is possible to reduce the size of the COF, and reduce the cost of the EL display (EL display panel).

[0300] FIG. 19 illustrates a configuration in which a plurality of driver input terminals **73** (**73a2**, **73b2**) are arranged for per driver input terminal **73** (**73a1**, **73b1**), and these driver input terminals are wire-connected through an internal line **262**. For example, the driver input terminals **73** (**73b1**, **73b2**) are formed as input terminals of two driver input terminals **Von2**, and the driver input terminals **73b1** and the driver input terminals **73b2** are electrically connected through a corresponding one of the internal lines **262**.

[0301] Similarly, for example, the driver input terminals **73** (**73b1**, **73b2**) are formed as input terminals of two driver input terminals, **73** and the driver input terminals **73b1** and the driver input terminals **73b2** are electrically connected through a corresponding one of the internal lines **262**.

[0302] In addition, some of the driver input terminals **73a2** are electrically connected through a COF line **74/1**. In addition, some of the driver input terminals **73a1** are electrically connected through a COF line **74/2**. Similarly, some of the driver input terminals **73b2** are electrically connected through a COF line **74/1**. Some of the driver input terminals **73b1** are electrically connected through a COF line **74/2**.

[0303] With this configuration, a plurality of V_{on1} voltages can be supplied to the driver input terminals **73a1** and **73a2** through a COF line **74a1** which supplies the voltages V_{on1} to the gate driver IC **12**. With this configuration, a plurality of voltages V_{on2} can be supplied to the driver input terminals **73a2** and **73a1** through a COF line **74a2** which supplies the voltages V_{on2} to the gate driver IC **12**.

[0304] In addition, a plurality of voltages V_{on1} can be supplied to the driver input terminals **73b1** and **73b2** through a COF line **74c1** which supplies the voltages V_{on1} to the gate driver IC **12**. In addition, a plurality of voltages V_{on2} can be supplied to the driver input terminals **73b1** and **73b2** through a COF line **74b2** which supplies the voltages V_{on2} to the gate driver IC **12**.

[0305] Although this embodiment has been described regarding the driver input terminals, the present disclosure is not limited thereto. For example, the embodiment in FIG. 19 or the technical idea can of course be applied also to control signal lines.

[0306] Although the above embodiments have been described regarding the control signals of the driver input terminals, the present disclosure is not limited thereto. For example, voltage supply lines explained in FIG. 19 may of course be combined therewith.

[0307] Needless to say, the above embodiments are also applicable to other embodiments in the present disclosure. Of course, the above embodiments can be combined with other embodiments.

[0308] An output waveform in FIG. 20B can be output from an output terminal of the gate driver IC 12. Output voltages are three voltages of off voltages (Voff1, Voff2), and an on voltage (Von). Since the three voltages are output, this drive is referred to as a three-value drive of gate voltages. Otherwise, it is referred to as a gate over drive.

[0309] As illustrated in FIG. 20A, a drive method using two voltages of an off voltage (Voff1) and an on voltage (Von) is referred to as a normal drive of gate voltages or a two-value drive of gate voltages.

[0310] The two-value drive of gate voltages (FIG. 20A) or the three-value drive of gate voltages (FIG. 20B) is determined based on a logic voltage to be applied to SEL terminals.

[0311] The voltage Von is a voltage for turning on a transistor 11 of a pixel 16. The voltages Voff1 and Voff2 are voltages for turning off the transistor 11 of the pixel 16. More specifically, the voltage Von ranges from 15 (V) to 30 (V) inclusive. The voltage Voff2 ranges from -15 (V) to -8 (V) inclusive. The voltage Voff1 ranges from -8 (V) to -3 (V) inclusive.

[0312] FIG. 21 is a diagram illustrating a three-value drive of gate voltages. A period Ta in which an on voltage (Von) is output is an nH period (n is an integer of 1 or larger, and H is a horizontal scanning period or a selection period of a pixel row). A period Tb in which a Voff2 is applied is a 1H period. In addition, 1F (F is a frame period or a field period)=Ta+Tb+Tc is satisfied.

[0313] In each of FIG. 21, FIGS. 22A and 22B, and FIGS. 20A and 20B, a two-value drive of gate voltages and the three-value drive of gate voltages are written assuming that transistors 11 are n-channel transistors. When the transistors 11 are p-channel transistors, the polarity of each of signal waveforms is inverted.

[0314] Each of FIGS. 22A and 22B is a diagram illustrating an on voltage Von, and shows an example of the two-value drive of gate voltages.

[0315] As illustrated in FIG. 22A, an on voltage VonA of a gate signal output circuit 53a is set in a voltage circuit E1 outside a COF. The voltage circuit E1 is a switching power supply circuit, a regulator circuit, or the like. The voltage circuit E1 outputs a voltage Von of the gate signal output circuit 53a. An on voltage VonB of a gate signal output circuit 53b is set in a voltage circuit E2 outside the COF. The voltage circuit E2 is a switching power supply circuit, a regulator circuit, or the like. The voltage circuit E2 outputs a voltage Von of the gate signal output circuit 53b. Von terminals are formed or arranged at least two positions on a gate driver IC 12.

[0316] As illustrated in FIG. 22B, it is possible to vary the amplitude of a voltage to be applied to gate signal lines 17 by setting the magnitudes of voltages Von (Von1, Von2). In FIG. 22B, the upper half thereof shows the voltage Von1 denoting an on voltage, and the lower half shows the voltage Von2 denoting an off voltage. Von1<von2 is satisfied. These voltage settings can be performed by the respective gate signal

output circuits 53 (53a, 53b). The application time of a voltage Von is assumed to be an nH (n is an integer of 1 or larger), and n can be varied by a controller (not illustrated).

[0317] As in the case of the voltages Von (Von1, Von2), voltages Voff (Voff1, Voff2) can also be varied or adjusted by the respective gate signal output circuits 53 (53a, 53b). These configurations are the same as in FIGS. 22A and 22B, and thus the same descriptions are not repeated.

[0318] Although the voltages Von (Von1, Von2) and voltages Voff (Voff1, Voff2) can be varied or adjusted by the respective gate signal output circuits 53 (53a, 53b) in each of FIGS. 22A and 22B, and FIGS. 20A and 20B, the present disclosure is not limited thereto. For example, among the voltages Von (Von1, Von2) in the plurality of gate signal output circuits 53 (53a, 53b), an arbitrary one or more of the plurality of voltages Von may be varied, adjusted, or set. In addition, either the voltage Voff1 or the voltage Voff2 may be varied, adjusted, or set.

[0319] FIG. 21 is a diagram illustrating the three-value drive of gate voltages. A voltage Von is applied to a pixel row selected by a shift register 51 in a horizontal scanning (1H) period (Period Ta: a pixel row selection period) or in a longer period. An application period Tb of a voltage Voff2 is a 1H period. A voltage Voff1 is applied in Period Tc, and a voltage Voff1 is applied and retained in Period Ta and periods other than Period Tb.

[0320] The application period Ta of the voltage Von is an nH period (n is an integer of 1 or larger) in which synchronization with a Clk signal is realized. The three-value drive of gate voltages in FIG. 21 is performed on gate signal lines 17a in FIG. 49, gate signal lines 17a illustrated in FIG. 48, and gate signal lines 17a in FIG. 44 to be described later. In other words, the three-value drive of gate voltages is performed on gate signal lines 17 to which transistors 11 for writing a video signal to pixels 16 are connected.

[0321] The voltage Voff2 is applied in the 1H period (Period Tb) in order to quickly stop selecting (turning off) pixels selected for being applied with a video signal, after writing the video signal thereto. In addition, the voltage Voff1 is retained (in Period Tc) in order to prevent a deep voltage (Voff2) from being applied to the gate terminal of the transistors 11 so as to prevent a change such as a Vt shift from occurring and changing a transistor characteristic.

[0322] As illustrated in FIG. 20A, in the two-value drive of gate voltages, it takes long time t1 to change from the voltage Von to the voltage Voff1. The long t1 causes a leak of the video signal written to the pixels in the period, resulting in a crosstalk between vertically adjacent pixels.

[0323] As illustrated in FIG. 20B, when the three-value drive of gate voltages is performed, it takes very short time t2 to change from the voltage Von to the voltage Voff1. Accordingly, no leak of the video signal written to the pixels occurs, and no crosstalk between vertically adjacent pixels occurs.

[0324] After an application period of the voltage Von, the voltage Voff2 is applied in a 1H period or a period (Period Tb) shorter than the 1H period. After an application period of the voltage Voff2, the voltage Voff1 is applied to the gate signal line 17 corresponding to the selected pixel row, and the gate signal line is retained at the voltage Voff1 in a period (Period Tc) before a next frame period in which a voltage Von is applied.

[0325] In the case of the two-value drive of gate voltages (a normal drive of gate voltages), there is no Period Tb as illustrated in FIG. 21, and thus no voltage Voff2 is applied to a

selected pixel row. Accordingly, the voltage V_{on} is applied in the period (Period T_a) selected by the shift register **51**; and, in the period (Period T_c), the voltage V_{off1} is applied, the off voltage is applied to the gate signal line **17**, and the transistors **11** connected to the gate signal line **17** are retained in an off state.

[0326] After an application period of the voltage V_{on} , the voltage V_{off2} is applied in a 1H period or in a period shorter than the 1H period. After an application period of the voltage V_{off2} , the voltage V_{off1} is applied to the gate signal line **17** corresponding to the selected pixel row, and the gate signal line **17** is retained at the voltage V_{off1} in a period before a next frame period in which a voltage V_{on} is applied.

[0327] It is to be noted that the two-value drive of gate voltages and the three-value drive of gate voltages are set by a logic signal to be applied to SEL (SEL1, SEL2) terminals. As illustrated in each of FIGS. **20A** and **20B**, a gate signal output circuit **53** is set to the mode of two-value drive of gate voltages when the logic voltage to be applied to the SEL (SEL1, SEL2) terminals is “L”. When the logic voltage to be applied to the SEL (SEL1, SEL2) terminals is “H”, the gate signal output circuit **53** is set to the mode of three-value drive of gate voltages.

[0328] As illustrated in FIG. **21**, the voltage V_{off2} applied in Period T_b after Period T_a (the period in which the video signal is written to the pixel row) reduces, to t_2 , the period for a transition from the V_{on} voltage application state to when the V_{off1} voltage level for turning off the transistors **11** is reached as illustrated in FIG. **20B**. As illustrated in FIG. **20A**, in the two-value drive of gate voltages, it takes long time t_1 to change from the V_{on} voltage level to the V_{off1} voltage level.

[0329] In the t_1 period in the two-value drive of gate voltages, the transistors connected to the gate signal lines **17** (**17a**, **17b**) are not in a completely off state, and thus, for example, video signals written to the pixels **16** leak. On the other hand, in the t_1 period in the three-value drive of gate voltages, since the applied voltage V_{off2} reduces, to t_2 , the period for the transition from the V_{on} voltage level to the V_{off1} voltage level, no video signals written to the pixels **16** do not leak. Accordingly, no crosstalk, signal leak, etc. occur, which enables generation of an excellent display image.

[0330] In the embodiment described with reference to FIG. **9**, setting the SEL1 terminal to the “H” logic enables setting of the gate signal output circuit **53a** to the three-value drive of gate voltages. Setting the SEL2 terminal to the “H” logic enables setting of the gate signal output circuit **53b** to the three-value drive of gate voltages. As described above, in the present disclosure, the SEL terminals enable a switch between the two-value drive of gate voltages and the three-value drive of gate voltages independently or individually for the gate signal output circuits **53** corresponding respectively to the gate signal lines **17**.

[0331] The gate signal output circuit **53a** is set to the three-value drive of gate voltages by setting the SEL1 terminal to the “H” logic, and the gate signal output circuit **53b** is set to the three-value drive of gate voltages by setting the SEL2 terminal to the “H” logic. The gate signal output circuit **53c** is set to the three-value drive of gate voltages by setting a SEL3 terminal to the “H” logic, and the gate signal output circuit **53d** is set to the three-value drive of gate voltages by setting a SEL4 terminal to the “H” logic.

[0332] FIG. **15** illustrates a possible configuration in which the SEL terminals are two terminals (SEL1, SEL2), the logic signal applied to these two terminals is decoded for use in

selecting one of the four gate signal output circuits **53** (**53a**, **53b**, **53c**, **53d**). The three-value drive of gate voltages is performed by the gate signal line **17** to which the transistor which writes the video signal to the pixels **16**. The gate signal line **17** is only one of the gate signal lines **17** (**17a**, **17b**) passing through each of the pixels. In other words, even when the plurality of gate signal driver circuits are formed in the gate driver IC **12**, one of them can be set to be subject to the three-value drive of gate voltages, and the other gate signal driver circuit may be subject to the two-value drive of gate voltages.

[0333] For example, when eight gate signal driver circuits are arranged or formed on a single gate driver IC **12**, the number of SEL terminals may be three, and a decoder (3-8 decoder) for selecting one of the eight 3-bit gate signal line driver circuits may be configured.

[0334] As described above, in the present disclosure, the SEL terminals enable a switch between the two-value drive of gate voltages and the three-value drive of gate voltages independently or individually for the gate signal output circuits **53** corresponding respectively to the gate signal lines **17**.

[0335] In the present disclosure, the gate signal line **17** connected to the transistors for wringing a video signal is driven by a both-side drive (performed by the two gate driver ICs **12** arranged right and left of a display screen **25**). The other gate signal lines for which fast slew rate is not required is driven by a one-side drive (performed by one of the gate driver ICs **12** arranged right and left of the display screen **25**).

[0336] In this embodiment of the present disclosure, the both-side drive means a drive performed by the two gate driver ICs **12** (**12a**, **12b**) arranged right and left of the display screen **25**. However, this is a non-limiting example. The both-side drive means any drive performed by the gate driver IC **12a**. For example, the both-side drive includes a drive in which two gate driver ICs (**12a**, **12b**) are connected or arranged at one side of a gate signal line **17**.

[0337] In other words, the both-side drive is a drive method in which the single gate signal line **17a** is driven by the plurality of gate driver ICs **12** (**12a**, **12b**). Although descriptions are given assuming that the gate signal line **17a** is driven by the gate driver ICs **12** (**12a**, **12b**), this is a non-limiting example. For example, the present disclosure covers a configuration in which gate driver circuits (not illustrated) are formed or arranged directly on a panel board **31** according to a technique using TAOS, or a low or high temperature polysilicon, and the gate driver circuits drive gate signal lines **17**.

[0338] Accordingly, the present disclosure covers a configuration in which gate driver circuits are connected to both sides of a single gate signal line **17**. The present disclosure further covers a configuration in which a gate driver IC **12** is connected to one side of a single gate signal line **17**, and a gate driver circuit is connected to the other end. The present disclosure further covers a configuration in which two gate driver circuits are connected to one side of a single gate signal line **17**.

[0339] The present disclosure is explained mainly taking, as an example, a method for applying a video signal voltage to pixels **16** (a program voltage method). However, this disclosure is a non-limiting example. A method for applying a video signal current to pixels **16** (a program current method) is also possible. A digital drive method, such as a PWM drive, for causing pixels **16** to display the video signal in a flickering or digitally flickering manner. Another drive method is also

possible. The drive method may be a luminescence area variation drive in which a luminescence area represents a luminescence intensity.

[0340] The PWM drive is, for example, a method in which a voltage of a predetermined value is applied to pixels 16 through switch transistors 11b to turn on or off switch transistors 11d, so that a video is displayed in grayscale according to the number of bits corresponding to the grayscale.

[0341] In addition, the switch transistors 11d are controlled to turn on and off to generate a belt-shaped black display (non-display) on the display screen 25 so as to control the amount of current flowing on the display screen 25.

[0342] FIG. 23 is a diagram for explaining a method for driving an EL display according to the present disclosure. In this disclosure, a gate driver IC 12a and a gate driver IC 12b are gate driver ICs having the same specifications. The gate driver IC 12a and the gate driver IC 12b are arranged in line symmetric with respect to the center axis of the display screen. The gate driver IC 12a and the gate driver IC 12b are different in logics of UD terminals (terminals which set scanning directions, not illustrated). In other words, the UD terminal of the gate driver IC 12a is set to perform scanning in Direction A, and the UD terminal of the gate driver IC 12b is set to perform scanning in Direction B.

[0343] Two gate signal output circuits 53 (53a, 53b) are arranged or formed in the gate driver ICs 12 (12a, 12b). A1, A2, A3, . . . and B1, B2, B3, . . . of the gate signal output circuits 53 denote data units (referred to as blocks 141) whose data is shifted according to a clock of a shift terminal (Clk terminal).

[0344] The gate signal output circuit 53a of the gate driver IC 12a drives a gate signal line 17a. The gate signal output circuit 53b of the gate driver IC 12a drives a gate signal line 17b.

[0345] In the gate signal output circuit 53a, Blocks A1 and B1 drive (control) pixels 16a, Blocks A2 and B2 drive (control) pixels 16b, and Blocks A3 and B3 drive (control) pixels 16c. The same applies to the succeeding blocks. In other words, in the gate driver IC 12a, an input of a clock (Clk) shifts the pixel row selection position by a pixel row.

[0346] In the gate signal output circuit 53b, Block A1 drives (controls) pixels 16a, Block B2 drives (controls) pixels 16b, and Block B2 drives (controls) pixels 16c. The same applies to the succeeding blocks. In other words, in the gate driver IC 12b, an input of a clock shifts the pixel row selection position by two pixel rows.

[0347] Accordingly, in order to cause the gate driver IC 12a and the gate driver IC 12b to select a pixel row in synchronization with each other, there is a need to cause the gate driver IC 12b to operate at a clock speed that is the half of the clock speed of the gate driver IC 12a.

[0348] The gate driver IC 17a of each pixel row is connected to the gate signal output line 53a of the gate driver IC 12a. In addition, the gate signal line 17a passing through an odd pixel row is connected to the gate signal output circuit 53a of the gate driver 12a, and the gate signal line 17b passing through an even pixel row is connected to the gate signal output circuit 53b of the gate driver 12b. The gate signal line 17b of each pixel row is connected to the gate signal output circuit 53b of the gate driver IC 12a.

[0349] With these connections, the gate signal line 17a of each pixel row is subject to a both-side drive by (i) the gate signal output circuit 53a of the gate driver IC 12a and (ii) the gate signal output circuit 53a and the gate signal output circuit

53b of the gate driver IC 12b. Accordingly, it is possible to drive, at a high slew rate, the gate signal line 17a to which the switch transistors 11b for applying a video signal to pixels are connected.

[0350] The gate signal line 17b is driven only by the gate signal output circuit 53b of the gate driver IC 12a. However, the switch transistor 11d does not require fast on and off actions. Accordingly, it is possible to realize practically sufficient characteristics by performing the one-side drive only by the gate signal output circuit 53b of the gate driver IC 12a.

[0351] The gate driver IC 12a drives the gate signal line 17a and the gate signal line 17b. The gate driver IC 12b drives only the gate signal line 17a. The gate driver IC 12a and the gate driver IC 12b have basically the same configurations. Accordingly, the number of gate driver ICs 12b arranged right of or connected to a display screen 25 may be the half of the number of gate driver ICs 12a arranged left of or connected to the display screen 25. For this reason, compared to a conventional EL display, the number of gate driver ICs 12 (12a, 12b) can be reduced, which enables cost reduction.

[0352] For example, in the EL display (EL display panel) illustrated in FIG. 24, the number of gate driver ICs 12a arranged left of a display screen 25 is four, and the number of gate driver ICs 12b arranged right of the display screen 25 is two that is the half of four.

[0353] FIG. 25 illustrates a wire-connection or a connection state of gate signal lines 17 (17a, 17b) in FIG. 24. In FIG. 25, the gate driver IC 12b is connected to the gate signal line 17a. The gate driver ICs 12a (12a1, 12a2) are connected to the gate signal line 17a and the gate signal line 17b. The gate signal line 17a and the gate signal line 17b receive an on voltage and an off voltage applied thereto.

[0354] The gate driver IC 12a and the gate signal line 17b are ICs having basically the same specifications although they are different in state of connections of control signal lines etc. (as illustrated in FIG. 26 etc.). The gate driver IC 12b drives the gate signal line 17a which needs to be subject to a both-side drive. The gate driver ICs 12a (12a1, 12a2) are connected to pixels. The gate driver IC 12a drives all gate signal lines 17 (17a, 17b). In other words, the gate driver ICs 12a drive the gate signal lines 17a which need to be subject to a both-side drive and the gate signal lines 17b to be subject to a one-side drive.

[0355] The plurality of gate signal output circuits 53 (53a, 53b) formed or arranged on the gate driver IC 12b drive the gate signal lines 17 (17a, 17b) at different pixel rows. For example, in the configuration in which the two gate signal lines 17 (17a, 17b) are provided per pixel as illustrated in FIG. 23, the gate signal output circuit 53a of the gate driver IC 12b drives the gate signal lines 17a passing through the odd pixel row, and the gate signal output circuit 53b drives the gate signal lines 17b passing through the even pixel row. As illustrated in FIG. 26, in the case of a configuration in which four gate signal lines are provided per pixel, and two of the gate signal lines 17 (17a, 17b) are subject to a both-side drive while the other two gate signal lines 17 (17a, 17b) are subject to a one-side drive, the gate signal output circuits 53a and 53b drive the gate signal lines 17 (17a, 17b) at each of the odd pixel rows, and the gate signal output circuits 53c and 53d drive the gate signal lines 17 (17c, 17d) at each of the even pixel rows. The four gate signal output circuits 53 (53a, 53b, 53c, 53d) of the gate driver IC 12a are sequentially drive the four gate signal lines 17 (17a, 17b, 17c, 17d) in a listed order

of a first odd pixel row, a first even pixel row, a second odd pixel row, and a second even pixel row.

[0356] FIG. 26 is a diagram illustrating an EL display according to the present disclosure. FIG. 26 illustrates control terminals etc. In the drawings of the present disclosure, parts that are unnecessary for explanation are not illustrated. In the embodiment with reference to FIG. 26, an output buffer 52 is arranged at an output side of the gate signal output circuits 53 (53a, 53b).

[0357] In FIG. 26, Dat (DatA1, DatA2, DatB1, DatB2) terminals are data input terminals of shift registers 51 (51a, 51b). By setting the Dat terminals to Data "H", on data is input to shift registers 51 (51a, 51b) according to a clock applied to clock terminals ((Clk (Clk1, ClkB1, ClkB2)). By setting the Dat terminals to Data "L", off data is input to the shift registers 51 (51a, 51b) by clocks applied to the clock terminals (Clk). When on data is retained in one of blocks 141 of one of the shift registers 51 (51a, 51b), an on voltage is applied or output to a corresponding one of gate signal lines 17 (17a, 17b, 17c, 17d), or on voltages in the gate signal line 17 is retained. When off data is retained in one of blocks 141 of one of the shift registers 51 (51a, 51b), an off voltage is applied or output to the corresponding one of the gate signal lines 17, or an off voltage in the gate signal line 17 is retained.

[0358] The on data and off data retained or latched in the shift registers 51 (51a, 51b) sequentially shift data retention states in the blocks 141 according to clock signals applied to the clock (Clk) terminals. A shift direction is changed by a logic signal applied to a UD terminal (not illustrated).

[0359] Enb terminals are terminals for controlling enable signals. By setting the Enb terminals to Data "H", an on voltage or an off voltage is output to the gate signal lines 17, in association with the on data or the off data retained or latched in the shift registers 51.

[0360] By setting the Enb terminals to Data "L", an off voltage is output to the gate signal lines 17 or an off voltage in the gate signal lines 17 is retained, irrespective of the on data or the off data retained or latched in the shift registers 51.

[0361] In FIG. 26, the gate signal output circuit 53a and the gate signal output circuit 53b of the gate driver IC 12a share a ClkA (clock) terminal, a UDA (up and down) terminal, and EnA ((EnbA1, EnbA2), enable) terminals. Each of the gate signal output circuit 53a and the gate signal output circuit 53b of the gate driver IC 12a has a corresponding one of Dat (data) terminals (DatA1, DatA2) for independent use. The EnbA1 terminal and the EnbA2 terminal are separate in the drawing sheet because the EnbA1 terminal is a terminal for controlling the gate signal line 17a to be an off state and the EnbA2 terminal is a terminal for controlling the gate signal line 17b to be an off state.

[0362] Although the clock terminal (ClkA) is not illustrated in the gate signal output circuit 53b of the gate driver IC 12a in the drawing of FIG. 26 etc. in the present disclosure, it is to be noted that the gate driver IC 12a has such a terminal. Although descriptions are given assuming that the gate driver ICs 12 (12a, 12b) are ICs, this is a non-limiting example. Alternatively, not to mention, the gate driver ICs 12 may be made of polysilicon or the like and formed directly on a glass board.

[0363] In FIG. 26, a gate signal output circuit 53a and a gate signal output circuit 53b of a gate driver IC 12b share a UDB (up and down) terminal. Each of the gate signal output circuit 53a and the gate signal output circuit 53b of the gate driver IC 12b has, for independent use, a corresponding one of Dat

(data) terminals (DatB1, DatB2), a corresponding one of Enb (enable) terminals (EnbB1, EnbB2), and a corresponding one of Clk (clock) terminals (ClkB1, ClkB2).

[0364] FIG. 27 is a diagram illustrating the gate driver IC 12a in detail. The gate driver IC 12b is the same as the gate driver IC 12a.

[0365] The gate driver IC 12a includes switch circuits 161. The switch circuits 161 are intended to realize the three-value drive of gate voltages in each of FIGS. 21 and 20B, and the two-value drive of gate voltages in each of FIGS. 22B and 20A.

[0366] Each of the switch circuits 161 has functions of selecting a voltage from among a voltage Voff1, a voltage Voff2, a voltage Von, and outputting the selected voltage to a corresponding one of the gate signal lines 17.

[0367] As illustrated in FIG. 28, a voltage Voff2 is applied to a terminal of each of the switch circuits 161 (161a, 161b), and a voltage Voff1 is applied to a b terminal of the same, and a voltage Von is applied to a c terminal of the same. One of the Voff2, Voff1, and voltages Von is selected by a logic signal applied to a d terminal (2 bits). The logic signal of the d terminal is based on data (Dat) retained in each of the shift registers 51 (51a, 51b).

[0368] The three-value drive of gate voltages illustrated in FIG. 20B is realized by means of one of the switch circuits 161 switching outputs in the following listed order: from the voltage Von via the voltage Voff2 to the voltage Voff1. The two-value drive of gate voltages illustrated in FIG. 20A is realized by means of one of the switch circuits 161 switching outputs in the following listed order: from the voltage Von via the voltage Voff2 to the voltage Voff1.

[0369] As illustrated in FIG. 29, an on voltage is applied to each of driver input terminals 73a. The plurality of driver input terminals 73a are gate signal output circuits 53 (53a, 53b) or output buffers 52 formed or configured in the gate driver ICs 12 (12a, 12b), and apply different voltages Von. These switch circuits 161 (161a, 161b) have been explained with reference to FIG. 28 etc., and thus the same explanation is not repeated.

[0370] As illustrated in FIG. 12, the two-value drive of gate voltages and the three-value drive of gate voltages are selected or set by logic signals to be applied to the SEL terminals. The SEL terminals are provided in each of gate signal output lines 53 (53a, 53b). The SEL terminals are set in a pull-down state in internal circuits of the gate driver ICs 12 (12a, 12b), and are set to the two-value drive of gate voltages in a default (the pull-down state). This is because the two-value drive of gate voltages consumes a smaller output voltage than the three-value drive of gate voltages, and has a lower risk of, for example, broking the gate driver ICs 12 (12a, 12b). By applying an H logic voltage to the SEL terminals, the gate signal output circuit 53 (53a, 53b) is set to the mode of a three-value drive of gate voltages.

[0371] The voltage Von, the voltage Voff1, the voltage Voff2 are input by external terminals of the gate driver ICs 12 (12a, 12b). In FIG. 12, the voltages Voff1 and Voff2 are illustrated as the ones shared by the gate signal output circuits 53 (53a, 53b). However, the present disclosure is not limited thereto. For example, terminals may be arranged in each of the gate signal output circuits 53 (53a, 53b) so that individual voltages Voff1 and Voff2 can be applied. The same applies to Von terminals.

[0372] The plurality of gate driver ICs **12** (**12a**, **12b**) are mounted on a display panel. The voltage V_{on} , voltage V_{off1} , and voltage V_{off2} are applied in common to the plurality of gate driver ICs **12** (**12a**, **12b**).

[0373] A voltage V_{on} and a voltage V_{off1} appropriate for each of gate signal lines **17** vary depending on a pixel circuit configuration. A requirement level for a V_{off2} also varies. Accordingly, it is preferable that the voltage V_{on} , voltage V_{off1} , and voltage V_{off2} can be set independently according to the kind of each gate signal line **17**.

[0374] For example, taking the pixel circuit in FIG. **5** as an example, it is preferable that the gate signal line **17a**, the gate signal line **17c**, the gate signal line **17d** and the gate signal line **17b** respectively have different and appropriate voltages V_{on} . Normally, a voltage V_{on} appropriate for the gate signal line **17b** is higher than those of the other gate signal lines **17**. This is because the voltage V_{on} to be applied to the switch transistor **11d** is made higher than the other so as to reduce an on resistance of the switch transistor **11d**. In addition, it is preferable that the gate signal line **17b** have an appropriate voltage V_{off1} different from those of the gate signal line **17a**, the gate signal line **17c**, and the gate signal line **17d**.

[0375] Normally, a voltage V_{off1} appropriate for the gate signal line **17b** is higher than those of the other gate signal lines **17** (**17a** to **17d**). This is because the voltage V_{off1} to be applied to the switch transistor **11d** is made higher than the other so as to reduce an absolute value ($V_{on}-V_{off1}$) of a voltage to be applied to the switch transistor **11d**.

[0376] The switch transistor **11b** performs a three-value drive of gate voltages, and the other switch transistors **11d**, **11c**, and **11e** perform a two-value drive of gate voltages. Accordingly, the gate signal line **17b** requires a voltage V_{off2} , but the other gate signals do not require any voltage V_{off2} . For this reason, as illustrated in FIG. **15**, in the gate driver IC **12**, each of gate signal output circuits **53** (**53a**, **53b**) is configured to independently apply a voltage V_{on} , a voltage V_{off1} , and a voltage V_{off2} . In addition, preferably, each of the gate signal output circuits **53** (**53a**, **53b**) be configured to cause SEL terminals to independently set a three-value drive of gate voltages and a two-value drive of gate voltages.

[0377] A voltage V_{off2} may be shared by the gate signal output circuits **53** (**53a**, **53b**). This is because, in most cases, one of the gate signal lines **17** which requires a voltage V_{off2} is identified by one of transistors **11** which applies a video signal.

[0378] A configuration in which a voltage V_{off1} and a voltage V_{off2} are shared by a plurality of signal output circuits **53** and voltages V_{on} are independent is also provided here as an example. In addition, a configuration in which a voltage V_{on} and a voltage V_{off2} are shared by a plurality of signal output circuits **53** and a voltage V_{off1} is independent is also provided here as another example.

[0379] Each of FIGS. **30A** and **30B** is a diagram illustrating a method for driving an EL display (EL display panel) of the present disclosure. To facilitate understanding, descriptions are given assuming that two gate signal lines **17** (**17a**, **17b**) pass through each of pixels **16**, a gate signal line **17a** is connected to switch transistors **11b** which apply a video signal to the pixels **16** (**16a** to **16n**), and is subject to a both-side drive, and a gate signal line **17b** is subject to an one-side drive. Here, connection states and wire-connection states of terminals (DataA1, EnbA1 etc.) mounted on each of gate signal output circuits **53** (**53a**, **53b**) of the gate driver IC **12** (**12a**, **12b**) are examples. These terminals are described as external

terminals for the gate driver ICs **12** (**12a**, **12b**) below, but the present disclosure is not limited thereto. For example, these terminals may be wire-connected or connected inside the gate driver ICs **12** (**12a**, **12b**).

[0380] In each of FIGS. **30A** and **30B**, the gate driver IC **12a** drives the gate signal lines **17a** and **17b**. The gate driver IC **12b** drives only the gate signal line **17a**.

[0381] In each of FIGS. **30A** and **30B**, each of circle marks in blocks **141** indicates that data is retained in the block **141** (A1 to An, B1 to Bn) of the gate signal output circuits **53a** and **53b** with the circle mark, and an on voltage (voltage V_{on}) is currently being output to the gate signal line **17a** used by each block **141** with the circle mark. The following descriptions are given assuming that an off voltage (a voltage V_{off1} or a voltage V_{off2}) is currently being output to each of the gate signal lines **17** (**17a**, **17b**) passing through each of blocks **141** without any circle mark. An on voltage is output from each block **141** with the circle mark when "H" is set to an Enb terminal, but when "L" is set to the Enb terminal, an off voltage is output as an output voltage to a corresponding one of the gate signal lines **17** (**17a**, **17b**) even from the block **141** with a circle mark.

[0382] In each of FIGS. **30A** and **30B**, a clock (Clk) terminal of the gate driver IC **12a** is shared by the gate signal output circuits **53a** and **53b**. The gate signal output circuit **53a** of the gate driver IC **12b** is a ClkB1, and the gate signal output circuit **53b** of the gate driver IC **12b** is a ClkB2. In other words, the gate signal output circuit **53a** and the gate signal output circuit **53b** of the gate driver IC **12b** operate according to different clocks. Alternatively, an identical clock is input to the gate signal output circuit **53a** and the gate signal output circuit **53b**, and the input clock is divided to a predetermined value in either the gate signal output circuit **53b** or the gate driver IC **12b**. Needless to say, the above matters are applicable to other embodiments in this DESCRIPTION.

[0383] In each of FIGS. **30A**, **30B**, etc., actions by the gate signal output circuit **53b** of the gate driver IC **12a** are not illustrated in order to facilitate understanding. With reference to each of FIGS. **30A**, **30B**, etc., the following descriptions are given focusing on applying an on voltage to the gate signal line **17a** and shifting an on voltage position. Furthermore, the following descriptions are given also focusing on actions, control, drive methods, and configurations of (i) the gate signal output circuit **53a** of the gate driver IC **12a**, and (ii) the gate signal output circuit **53a** and the gate signal output circuit **53b** of the gate driver IC **12b**.

[0384] Actions etc. of the gate signal output circuit **53b** of the gate driver IC **12a** are not explained. This is because actions or methods for driving the gate signal output circuit **53b** are identical or similar to those of the gate signal output circuit **53a** of the gate driver IC **12a**. More specifically, this is because the method performed by the gate signal output circuit **53a** of the gate driver IC **12a** to select the gate signal line **17a** or control an on voltage position is identical or similar in actions to the method performed by the gate signal output circuit **53b** of the gate driver IC **12a** to select the gate signal line **17b** or control an on voltage position.

[0385] In each of FIGS. **30A**, **30B**, etc.: the position of data (with a circle mark) indicating the level of a voltage signal applied to the Clk (ClkA, ClkB1, ClkB2) terminal or a signal edge is shifted to another one of the blocks **141**; or a voltage of a logic level assigned to the Clk terminal is input to the block **141**.

[0386] To facilitate understanding or simplify the drawings, descriptions regarding a latch and a shift of data by the Clk (ClkA, ClkB1, ClkB2) terminal are not provided.

[0387] In each of FIGS. 30A and 30B, the “H” of each of Dat (DatA1, DatA2, DatB1, DatB2) terminals denotes a state in which data for outputting an on voltage to a corresponding one of the gate signal lines 17 (17a, 17b) is to be set or input, or has been input. The “L” of the Dat terminal denotes a state in which data for outputting an off voltage to the corresponding gate signal line 17 is to be set or input, or has been input. The “H” of the Enb terminal indicates a state in which an on voltage or an off voltage is output or to be output to the corresponding gate signal lines 17, based on the setting state of one or more of the blocks 141 (the block(s) 141 with the circle mark indicates that an on voltage is output to the corresponding gate signal lines 17, and each of the blocks 141 without any circle mark indicates that an off voltage is output to the corresponding gate signal lines 17). The “L” of each of the Enb (EnbA1, EnbA2, EnbB1, EnbB2) terminals indicates a state in which an off voltage is output or to be output to a corresponding one of the gate signal lines 17 (17a, 17b), irrespective of the setting state(s) of current one or more of the blocks 141 (the block(s) 141 with the circle mark indicates that an on voltage is output to the corresponding gate signal line 17, or each of the blocks 141 without any circle mark indicates that an off voltage is output to the corresponding gate signal line 17).

[0388] In each of FIGS. 30A and 30B, the DatA1 terminal and the EnbA1 terminal are connected to the gate signal output circuit 53a of the gate driver IC 12a, and the ClkA terminal is connected in common to the gate signal output circuit 53b. The DatA2 terminal and the EnbA2 terminal are connected to the gate signal output circuit 53b. In addition, the DatB1 terminal, the EnbB1 terminal, and the ClkB1 terminal are connected to the gate signal output circuit 53a of the gate driver IC 12b, and the DatB2 terminal, the EnbB2 terminal, and the ClkB2 terminal are connected to the gate signal output circuit 53b of the gate driver IC 12b.

[0389] In FIG. 30A, in the gate driver IC 12a, the DatA1 terminal is set to “H”, the EnbA1 terminal is set to “H”, the DatA2 terminal is set to “L”, and the EnbA2 terminal is set to “L”.

[0390] The DatA2 terminal of the gate driver IC 12a is set to “L” because actions regarding control of the gate signal lines 17b are not explained in order to facilitate understanding. The DatA2 terminal is, of course, set to “H” or “L” and the EnbA2 terminal is set to “H” or “L” since on and off control is performed for the gate signal lines 17b of the gate driver IC 12a in the method for driving the EL display (EL display panel) in the actual disclosure herein.

[0391] In FIG. 30A, in the gate driver IC 12a, the DatA1 terminal is set to “H”, the EnbA1 terminal is set to “H”, the DatA2 terminal is set to “L”, and the EnbA2 terminal is set to “L”. Triggered by an input of the ClkA terminal, on data (with a circle mark) is input to the block (A1) of the blocks 141 of the gate signal output circuit 53a of the gate driver IC 12a. Since the EnbA1 terminal of the gate signal output circuit 53a of the gate driver IC 12a is set to “H”, an on voltage is output to the gate signal line 17a passing through the pixel 16a. Accordingly, a video signal applied to a source signal line (not illustrated) is applied to the pixel 16a.

[0392] Likewise, in the gate driver IC 12b, the DatB1 terminal is set to “H” and the EnbB1 terminal is set to “H”. Triggered by an input of the ClkB1 terminal, on data (with a

circle mark) is input to the block 141 (A1) of the gate signal output circuit 53a of the gate driver IC 12b. Since the EnbB1 terminal of the gate signal output circuit 53a of the gate driver IC 12b is set to “H”, an on voltage is output to the gate signal line 17a passing through the pixel 16a.

[0393] With the settings or control states, the gate signal line 17a passing through the pixel 16a is subject to a both-side drive by the gate signal output circuit 53a of the gate driver IC 12a and the gate signal output circuit 53a of the gate driver IC 12b.

[0394] The DatB2 terminal is set to “L” and the EnbB2 terminal is set to “L” in the gate driver IC 12b, and thus, triggered by the input of the ClkB2 terminal, off data (without a circle mark) is input to the block (B1) of the blocks 141 of the gate signal output circuit 53b of the gate driver IC 12b. Since the EnbB2 terminal of the gate signal output circuit 53b of the gate driver IC 12b is set to “L”, an off voltage is output to the gate signal line 17a passing through the pixels 16b. In this case, an off voltage is output to the gate signal line 17a of the pixel 16b because off data (without a circle mark) is retained in the block 141 (B1) of the gate signal output circuit 53b of the gate driver IC 12b even when the EnbB2 terminal of the gate signal output circuit 53b of the gate driver IC 12b is set to “H”.

[0395] In other words, voltages (an on voltage and an off voltage) to be output to the gate signal line 17a of the gate driver IC 12b can be controlled using data latched or retained in the block 141. In addition, such control can also be performed by logic setting of the EnbB2 terminal. Accordingly, needless to say, any of these methods is possible in the method for driving the EL display (EL display panel) of the present disclosure.

[0396] With the actions and control, in FIG. 30A, a both-side drive is performed on the gate signal line 17a passing through the pixels 16a, and an off voltage is applied to the gate signal lines 17a passing through the other pixels 16. Needless to say, it is only necessary that an on or off voltage may be applied to the gate signal line 17b by the gate signal output circuit 53b of the gate driver IC 12a as necessary.

[0397] In FIG. 30B, in the gate driver IC 12a, the DatA1 terminal is set to “L”, the EnbA1 terminal is set to “H”, the DatA2 terminal is set to “L”, and the EnbA2 terminal is set to “L”. Triggered by an input of the ClkA terminal, off data (without a circle mark) is input to the block 141 (A1) of the gate signal output circuit 53a of the gate driver IC 12a. The on data (with a circle mark) of the block (A1) is transferred (shifted) to the block (A2) of the blocks 141.

[0398] Since the EnbA1 terminal of the gate signal output circuit 53a of the gate driver IC 12a is set to “H”, an off voltage is output to the gate signal line 17a passing through the pixels 16a, and an on voltage is output to the gate signal line 17a passing through the pixels 16b. Accordingly, a video signal applied to a source signal line (not illustrated) is applied to the pixels 16b. The video signal firstly applied to the pixels 16a is retained.

[0399] Likewise, in the gate driver IC 12b, the DatB2 terminal is set to “H” and the EnbB2 terminal is set to “H”. Triggered by an input of the ClkB2 terminal, on data (with a circle mark) is input to the block 141 (B1) of the gate signal output circuit 53b of the gate driver IC 12b. Since the EnbB2 terminal of the gate signal output circuit 53b of the gate driver IC 12b is set to “H”, an on voltage is output to the gate signal line 17a of the pixels 16b.

[0400] With the settings or control states, the gate signal line 17a passing through the pixels 16b is subject to a both-side drive by the gate signal output circuit 53a of the gate driver IC 12a and the gate signal output circuit 53b of the gate driver IC 12b.

[0401] In FIG. 30B, no clock is input to the ClkB1 terminal of the gate driver IC 12b. Accordingly, the data retained in the block 141 (A1) of the gate signal output circuit 53a of the gate driver IC 12b is not transferred to the block 141 (A2). Since the EnbB1 terminal is set to "L", an off voltage is applied to the gate signal line 17a passing through the pixels 16a.

[0402] With the actions and control, in FIG. 30B, the gate signal 17a passing through the pixels 16b is subject to a both-side drive, and an off voltage is applied to the gate signal lines 17a passing through the other pixels 16 (16c, 16d, . . . 16n). Needless to say, it is only necessary that an on or off voltage may be applied to the gate signal line 17b by the gate signal output circuit 53b of the gate driver IC 12a as necessary.

[0403] FIGS. 31A and 31B illustrate control similar to control illustrated in FIGS. 30A and 30B.

[0404] In FIG. 31A, in the gate driver IC 12a, the DatA1 terminal is set to "L", the EnbA1 terminal is set to "H", the DatA2 terminal is set to "L", and the EnbA2 terminal is set to "L". Triggered by an input of the ClkA terminal, off data (without a circle mark) is input to the block 141 (A1) of the gate signal output circuit 53a of the gate driver IC 12a. Since the EnbA1 terminal of the gate signal output circuit 53a of the gate driver IC 12a is set to "H", an off voltage is output to the gate signal line 17a passing through the pixels 16a, as a result of reflection of the data state in the block 141 (A1). In addition, triggered by the input of the ClkA terminal, data of the block 141 (A2) is transferred to the block (A3) of the blocks 141. An on voltage is output to the gate signal line 17a passing through the pixels 16c, and a video signal applied to a source signal line (not illustrated) is applied to the pixels 16c.

[0405] Likewise, in the gate driver IC 12b, the DatB1 terminal is set to "L" and the EnbB1 terminal is set to "H". Triggered by an input of the ClkB1 terminal, off data (without a circle mark) is input to the block 141 (A1) of the gate signal output circuit 53a of the gate driver IC 12b. The data of the block 141 (A1) of the gate signal output circuit 53a of the gate driver IC 12b is transferred to the block 141 (A2). Since the EnbB1 terminal of the gate signal output circuit 53a of the gate driver IC 12b is set to "H", an off voltage is output to the gate signal line 17a of the pixel 16a, and an on voltage is output to the gate signal line 17a passing through the pixels 16c.

[0406] With the settings or control states, the gate signal line 17a passing through the pixels 16c is subject to a both-side drive by the gate signal output circuit 53a of the gate driver IC 12a and the gate signal output circuit 53a of the gate driver IC 12b.

[0407] Since the DatB2 terminal is set to "L" and the EnbB2 terminal is set to "L" in the gate driver IC 12b and there is no input to the ClkB2 terminal, data of the gate signal output circuit 53b of the gate driver IC 12b is not shifted. Accordingly, the data retained in the block 141 (B1) of the gate signal output circuit 53b of the gate driver IC 12b is not transferred to the block 141 (B2). Since the EnbB1 terminal is set to "L", an off voltage is applied to the gate signal line 17a passing through the pixel 16b.

[0408] With the settings or control states, the gate signal line 17a passing through the pixels 16c is subject to a both-

side drive by the gate signal output circuit 53a of the gate driver IC 12a and the gate signal output circuit 53a of the gate driver IC 12b.

[0409] With the actions and control, in FIG. 31A, a both-side drive is performed on the gate signal line 17a passing through the pixels 16c, and an off voltage is applied to the gate signal lines 17a of the other pixels. Needless to say, it is only necessary that an on or off voltage may be applied to the gate signal line 17b by the gate signal output circuit 53b of the gate driver IC 12a as necessary.

[0410] In FIG. 31B, in the gate driver IC 12a, the DatA1 terminal is set to "L", the EnbA1 terminal is set to "H", the DatA2 terminal is set to "L", and the EnbA2 terminal is set to "L". Triggered by an input of the ClkA terminal, off data (without a circle mark) is input to the block 141 (A1) of the gate signal output circuit 53a of the gate driver IC 12a. Since the EnbA1 terminal of the gate signal output circuit 53a of the gate driver IC 12a is set to "H", an off voltage is output to the gate signal line 17a of the pixel 16a, as a result of reflection of the data state in the block 141 (A1). In addition, triggered by an input of the ClkA terminal, data of the block 141 (A3) is transferred to the block 141 (A4). An on voltage is output to the gate signal line 17a passing through the pixels 16d, and a video signal applied to a source signal line 18 (not illustrated) is applied to the pixels 16d.

[0411] Likewise, in the gate driver IC 12b, the DatB2 terminal is set to "L" and the EnbB2 terminal is set to "H". Triggered by an input of the ClkB2 terminal, off data (without a circle mark) is input to the block 141 (B1) of the gate signal output circuit 53a of the gate driver IC 12b. The data of the block 141 (B1) of the gate signal output circuit 53a of the gate driver IC 12b is transferred to the block 141 (B2). Since the EnbB1 terminal of the gate signal output circuit 53b of the gate driver IC 12b is set to "H", an off voltage is output to the gate signal line 17a passing through the pixels 16b, and an on voltage is output to the gate signal line 17a of the pixels 16d.

[0412] With the settings or control states, the gate signal line 17a passing through the pixels 16d is subject to a both-side drive by the gate signal output circuit 53a of the gate driver IC 12a and the gate signal output circuit 53b of the gate driver IC 12b.

[0413] Since the DatB2 terminal is set to "L" and the EnbB2 terminal is set to "L" in the gate driver IC 12a and there is no input to the ClkB1 terminal, data of the gate signal output circuit 53a of the gate driver IC 12b is not shifted. Accordingly, the data retained in the block 141 (A1) of the gate signal output circuit 53a of the gate driver IC 12b is not transferred to the block 141 (A2). Since the EnbB1 terminal is set to "L", an off voltage is applied to the gate signal line 17a passing through the pixels 16c.

[0414] With the settings or control states, the gate signal line 17a passing through the pixels 16d is subject to a both-side drive by the gate signal output circuit 53a of the gate driver IC 12a and the gate signal output circuit 53b of the gate driver IC 12b.

[0415] With the actions and control, in FIG. 31B, a both-side drive is performed on the gate signal line 17a passing through the pixels 16c, and an off voltage is applied to the gate signal lines 17a passing through the other pixels 16c. Needless to say, it is only necessary that an on or off voltage may be applied to the gate signal line 17b by the gate signal output circuit 53b of the gate driver IC 12a as necessary.

[0416] As described above, the gate signal line 17a passing through the pixel 16c is subject to the both-side drive by

means that: the gate driver IC 12a shifting the data positions of the gate signal output circuits 53a and 53b in synchronization with the ClkA terminal; and the gate driver IC 12b controlling the gate signal output circuits 53a and 53b according to different clocks (ClkB1, ClkB2) alternately or independently and controlling the EnbB1 terminal and the EnbB2 terminal alternately or independently.

[0417] In this embodiment, the clock ClkB1 of the gate signal output circuit 53a and the clock ClkB2 of the gate signal output circuit 53b of the gate driver IC 12b are caused to act alternately, and the data positions (with and without a circle mark) in the blocks 141 are shifted. However, the present disclosure is not limited thereto.

[0418] For example, in each of FIGS. 31A and 30B, a circle mark is present in each of the block 141 (A2) of the gate signal output circuit 53a and the block 141 (B1) of the gate signal output circuit 53b. When the clocks ClkB1 and ClkB2 are input to the gate signal output circuits 53a and 53b at the same time, the positions of circle marks are shifted to the positions of blocks 141 illustrated in FIG. 31B. In other words, the positions of the circle marks are shifted to the position of the block 141 (A2) in the gate signal output circuit 53a and the position of the block 141 (B2) of the gate signal output circuit 53b.

[0419] When the enable terminal EnbB1 of the gate signal output circuit 53a is set to "H" and the enable terminal EnbB2 of the gate signal output circuit 53b is set to "L" in the state of FIG. 31B, an on voltage is applied to the gate signal line 17a passing through the pixels 16c and an off voltage is applied to the gate signal line 17a passing through the pixels 16d. At this time, when the gate driver IC 12a applies an on voltage to the gate signal line 17a of the pixels 16c, the gate signal line 17a passing through the pixels 16c is subject to a both-side drive. When the enable terminal EnbB1 of the gate signal output circuit 53a is set to "L" and the enable terminal EnbB2 of the gate signal output circuit 53b is set to "H" in the state of FIG. 31B, an on voltage is applied to the gate signal line 17a passing through the pixels 16d and an off voltage is applied to the gate signal line 17a passing through the pixels 16a. At this time, when the gate driver IC 12a applies an on voltage to the gate signal line 17a of the pixels 16d, the gate signal line 17a passing through the pixels 16d is subject to a both-side drive.

[0420] As described above, the drive methods of the present disclosure can of course be performed also by, for example, controlling the gate driver IC 12a and the gate driver IC 12b, or controlling the gate signal output circuit 53a and the gate signal output circuit 53b of each of the gate driver ICs 12. These matters apply also to control of the gate signal line 17b. Needless to say, these are also applicable in other embodiments of the present disclosure.

[0421] The above embodiment describes a case where a single mark is provided to some of blocks 141 of each of the gate signal output circuits 53 (53a, 53b). However, the present disclosure is not limited thereto. Data (with or without a circle mark) input to each of shift registers 51 (51a, 51b) inside the gate signal output circuits 53 (53a, 53b) is made through the clock terminals (Clk) and the data terminals (Dat). Accordingly, it is only necessary to control or operate the data terminals and the clock terminals in order to input data to shift registers 51 (51a, 51b) etc. Accordingly, consecutive data items with a circle mark can be input to the shift registers 51, and discrete data items with a circle mark can be serially input to the shift registers 51 (51a, 51b).

[0422] Each of FIGS. 32A and 32B illustrates an embodiment in which consecutive data items with a circle mark are input to either the gate signal output circuits 53 (53a, 53b) or the shift registers 51 (51a, 51b).

[0423] This embodiment of the present disclosure is given focusing on an example of consecutive data items with a circle mark, as illustrated for the purpose of facilitating understanding. In reality, not to mention, data items without a circle mark are retained in blocks 141 other than blocks 141 with a circle mark in the shift register 51.

[0424] In FIG. 32A, the gate driver IC 12a is in a state where the DatA1 terminal is set to "H", and a clock is input to the ClkA terminal twice (no description regarding the gate signal output circuit 53b of the gate driver IC 12a is provided here). Accordingly, a circle mark (an on voltage position) is retained in each of the blocks 141 (A1, A2) of the gate signal output circuit 53a of the gate driver IC 12a. By setting the EnbA1 terminal of the gate signal output circuit 53a of the gate driver IC 12a to "H", an on voltage is applied (output) to each of the gate signal lines 17a each passing through the pixel 16a or the pixel 16b.

[0425] On the other hand, by applying an "H" logic to the DatB1 and DatB2 terminals of the gate driver IC 12b and inputting a clock signal to the ClkB1 and ClkB2 terminals once, a circle mark position (on voltage position) is retained in the block 141 (A1) of the gate signal output circuit 53a and the block 141 (B1) of the gate signal output circuit 53b of the gate driver IC 12b. By setting the EnbB1 terminal and the EnbB2 terminal of the gate signal output circuit 53a of the gate driver IC 12b to "H", an on voltage is applied (output) to each of the gate signal lines 17a each passing through the pixels 16a or the pixels 16b. The EnbA1 terminal of the gate driver IC 12a is set to With the settings or control states, each of the gate signal lines 17a each passing through the pixels 16a or the pixels 16b is subject to a both-side drive by the gate signal output circuit 53a of the gate driver IC 12a and the gate signal output circuits 53a and 53b of the gate driver IC 12b.

[0426] FIG. 32B illustrates a state created by setting the DatA1 terminal of the gate signal output circuit 53a of the gate driver IC 12a to "L", and inputting a clock to the ClkA terminal once in the state of FIG. 32A. The circle mark positions of the gate signal output circuit 53a are shifted by one block 141 from the positions in FIG. 32A to the positions of blocks 141 (A2, A3). The state is a state in which the DatB1 and DatB2 terminals of the gate signal output circuit 53a of the gate driver IC 12b are set to "L", and a clock is input to the ClkB1 terminal once. The circle mark position of the gate signal output circuit 53a of the gate driver IC 12b is shifted by one block from the position in FIG. 32A to the position of the block 141 (A2). It is to be noted that no clock is input to the ClkB2 terminal in the gate signal output circuit 53b of the gate driver IC 12b, and thus the circle mark position remains at the block 141 (B1). The EnbB1 and EnbB2 terminals of the gate driver IC 12b are set to "H".

[0427] With the settings or control states, the gate signal lines 17a each passing through the pixels 16b or the pixels 16c are subject to a both-side drive by the gate signal output circuit 53a of the gate driver IC 12a and the gate signal output circuits 53a and 53b of the gate driver IC 12b. Accordingly, compared to FIG. 32A, the on voltage position to the gate signal line 17a is shifted by one pixel in FIG. 32B.

[0428] FIG. 33A illustrates a state created by setting the DatA1 terminal of the gate signal output circuit 53a of the gate driver IC 12a to "L", and inputting a clock to the ClkA

terminal once in the state of FIG. 32B. The circle mark positions in the gate signal output circuit 53a are shifted by one block 141 to positions of the blocks 141 (A3, A4). The state is a state in which DatB1 and DatB2 terminals of the gate signal output circuit 53a of the gate driver IC 12b are set to “L”, and a clock is input to the ClkB2 terminal once. One of the circle mark positions in the gate signal output circuit 53b of the gate driver IC 12b is shifted by one block to the position of the block 141 (B2). Accordingly, the circle mark positions of the gate driver IC 12b are the blocks 141 (A2, B2). The EnbB1 and EnbB2 terminals of the gate driver IC 12b are set to “H”.

[0429] With the settings or control states, the gate signal lines 17a each passing through the pixels 16c or the pixels 16d are subject to a both-side drive by the gate signal output circuit 53a of the gate driver IC 12a and the gate signal output circuits 53a and 53b of the gate driver IC 12b. Accordingly, compared to FIG. 32B, the on voltage position to the gate signal line 17a is shifted by one pixel in FIG. 33A.

[0430] FIG. 33B illustrates a state created by setting the DatA1 terminal of the gate signal output circuit 53a of the gate driver IC 12a to “L”, and inputting a clock to the ClkA terminal once in the state of FIG. 33A. The circle mark positions of the gate signal output circuit 53a are shifted by one block 141 from the positions in FIG. 33A to the positions of the blocks (A4, A5). The state is a state in which the DatB1 and DatB2 terminals of the gate signal output circuit 53a of the gate driver IC 12b are set to “L”, and a clock is input to the ClkB1 terminal once. One of the circle mark positions of the gate signal output circuit 53a of the gate driver IC 12b is shifted by one block from the position in FIG. 32A to the position of the block 141 (A3). Accordingly, the circle mark positions of the gate driver IC 12b are the blocks 141 (A3, B2). The EnbB1 and EnbB2 of the gate driver IC 12b are set to “H”.

[0431] With the settings or control states, the gate signal lines 17a each passing through the pixels 16d or the pixels 16e are subject to a both-side drive by the gate signal output circuit 53a of the gate driver IC 12a and the gate signal output circuits 53a and 53b of the gate driver IC 12b. Accordingly, compared to FIG. 33A, the on voltage position to the gate signal line 17a is shifted by one pixel in FIG. 33B.

[0432] As described above, the consecutive circle mark positions are sequentially shifted to the positions of blocks 141 of the shift registers 51. With reference to FIGS. 32A, 32B, 33A, and 33B, descriptions are given assuming that both of the gate driver IC 12a and the gate driver IC 12b perform control or operate when the circle mark positions are consecutive. However, needless to say, the present disclosure is not limited thereto. Circle mark positions may be discrete at one of the sides of the gate driver IC 12a and the gate driver IC 12b, and/or three or more circle mark positions may be consecutive.

[0433] Each of FIGS. 34A and 34B is a diagram illustrating control or an operation of the gate signal output circuit 53b of the gate driver IC 12a. The actions or operations of the gate driver IC 12b are identical or similar to the actions described earlier, and thus is not described here.

[0434] FIG. 34A illustrates a state in which the DatA2 terminal of the gate signal output circuit 53b of the gate driver IC 12a is set to “H”, and a clock is input to the ClkA terminal three times. When data items (with a circle mark) are input to the gate signal output circuit 53b, and circle mark positions in some of the blocks 141 are shifted to the positions of the blocks 141 (B1, B2, B3). FIG. 34A illustrates a state in which

the DatA1 terminal of the gate signal output circuit 53a of the gate driver IC 12a is set to “H”, and a clock is input to the ClkA terminal once. The EnbA1 and EnbA1 terminals of the gate driver IC 12a are set to “H”.

[0435] In the above settings and control states, an on voltage is output to the gate signal lines 17b each passing through the pixels 16a, 16b, or 16c. In addition, an on voltage is output to the gate signal line 17a passing through the pixels 16a. Accordingly, the gate signal line 17a passing through the pixels 16a is subject to a both-side drive, and the gate signal lines 17b each passing through the pixels 16a, 16b, or 16c are subject to a one-side drive. In the pixel configuration in FIG. 50, the switch transistor 11d are connected to the gate signal line 17b, and controls a current that the driver transistors 11a flow into EL elements 15. Accordingly, an on voltage applied to the gate signal line 17b switches on the switch transistors 11d so that the EL elements 15 receive supply of the current and turn on. On the other hand, the EL elements 15 do not receive supply of a current when the switch transistors 11d are off, and are in an off state.

[0436] With the above actions or operations, it is possible to turn on or off an arbitrary pixel row of the EL display (EL display panel) by controlling or operating the gate signal output circuit 53b of the gate driver IC 12a. In addition, a duty drive can be performed by switching-on positions. Needless to say, the above embodiments are also applicable to other embodiments in the present disclosure. In addition, the above embodiments can be combined with other embodiments.

[0437] FIG. 34B illustrates a state in which the DatA2 terminal of the gate signal output circuit 53b of the gate driver IC 12a is set to “L”, and a clock is input to the ClkA terminal once. When data items (without a circle mark) are input to the gate signal output circuit 53b, and circle mark positions in some of the blocks 141 are shifted to the positions of the blocks 141 (B2, B3, B4). FIG. 34B illustrates a state in which the DatA1 terminal of the gate signal output circuit 53a of the gate driver IC 12a is set to “L”, and a clock is input to the ClkA terminal once. The EnbA1 and EnbA1 terminals of the gate driver IC 12a are set to “H”.

[0438] In the above settings and control states, an on voltage is output to the gate signal lines 17b each passing through the pixels 16b, 16c, or 16d. In addition, an on voltage is output to the gate signal line 17a passing through the pixels 16b. Accordingly, the gate signal line 17a passing through the pixel 16b is subject to a both-side drive, and the gate signal lines 17b each passing through the pixels 16b, 16c, or 16d are subject to a one-side drive.

[0439] As described above, each of the gate signal lines 17a is subject to the both-side drive by the gate signal output circuit 53a of the gate driver IC 12a and the gate signal output circuits 53a and 53b of the gate driver IC 12b. The gate signal output circuit 53b of the gate driver IC 12a performs a one-side drive on the gate signal line 17b.

[0440] As described above, the consecutive circle mark positions are sequentially shifted to positions of blocks 141 of the shift registers 51, and a duty drive etc. is performed.

[0441] In the present disclosure as described above, the gate driver IC 12a and the gate driver IC 12b have the same gate driver ICs 12 intended to realize or perform either a both-side drive or a one-side drive on each gate signal line 17 by controlling or operating control terminals (such as Dat terminals, Enb terminals, Clk terminals) according to posi-

tions (a right position of the display screen **25**, a left position of the display screen **25**) at which the EL display (EL display panel) is mounted.

[0442] Accordingly, by generating gate drivers IC **12** (**12a**, **12b**) of one kind according to the present disclosure and mounting them on EL displays having a wide variety of pixel circuits, the EL displays which realize excellent image display can be provided. The gate driver ICs **12** (**12a**, **12b**) of the present disclosure can be appropriate for such a wide variety of pixel circuits. Accordingly, the gate driver ICs **12** (**12a**, **12b**) can be used as general-purpose ones. Since mass production of these ICs is possible, the cost can be reduced.

[0443] In addition, the gate driver ICs **12** (**12a**, **12b**) of the present disclosure can set scanning directions for the shift registers using a vertical inverse setting logic terminal (the UD terminal, for example see FIG. **15**). Accordingly, the gate driver ICs **12a** and **12b** can be arranged right and left of the display screen **25** and used. Accordingly, it is possible to easily perform a both-side drive or a one-side drive of each gate signal line **17**. In addition, it is possible to reduce the number of gate driver ICs **12** (**12a**, **12b**) and reduce cost by performing a one-side drive.

[0444] Furthermore, the three-value drive of gate voltages and the two-value drive of gate voltages are realized by performing control or setting on SEL terminals etc. In particular, since an EL display (EL display panel) includes a plurality of gate signal lines **17** passing through pixels **16**, the physical positions of the gate signal lines **17** which should be subject to a both-side drive for pixels are not determined until the pixels are laid out (the physical positions are, for example, the positions of the gate signal lines **17a** which apply a video signal to corresponding ones of the pixels **16**). However, it is unpractical to develop or design gate driver ICs **12** (**12a**, **12b**) etc. after the pixel layout design was completed because it takes significantly long time to complete manufacturing the EL display (EL display panel). In the present disclosure, the gate driver ICs **12** (**12a**, **12b**) can be mounted on any of positions (a right position of the display screen **25**, a left position of the display screen **25**) in the EL display (the EL display panel). Furthermore, it is possible to easily perform a both-side drive or a one-side drive on each gate signal line **17** by, for example, controlling the gate signal output circuit **53**. It is possible to select and perform either the three-value drive of gate voltages or the two-value drive of gate voltages on any of the gate signal lines **17**.

[0445] In addition, as illustrated in each of FIGS. **14**, **12**, **17**, and **18**, for example, logic setting of each driver IC is performed by branching an input control line **261** etc. from a panel side. Accordingly, since the number of lines to be formed on the COF can be reduced, the panel module without a gate printed board (PCB) can easily be configured to be thin.

[0446] As illustrated in each of FIGS. **8A**, **8B**, **9**, **19**, and **21**, since the number of lines to be formed on the COF can be reduced by forming an internal line inside each driver IC, the panel module without a gate printed board (PCB) can easily be configured to be thin.

[0447] In addition, the pixels according to the present disclosure are similar to the pixels **16** illustrated in FIG. **5**, and are not described in detail here.

[0448] FIG. **35** is a diagram illustrating a method for driving an EL display (EL display panel) of the present disclosure. In FIG. **35** etc., a scanning direction of gate drivers IC **12** (**12a**, **12b**) is set by providing settings of logic terminals of control terminals (UDA, UDB) according to a vertical inverse

method. The scanning direction of the gate driver IC **12a** and the gate driver IC **12b** is a direction from top to down in the drawing sheets.

[0449] The gate driver ICs **12** (**12a**, **12b**) have identical or similar specifications or configurations. Accordingly, the UDA terminal of the gate driver IC **12a** and the UDB terminal of the gate driver IC **12b** are provided with opposite logic settings. For example, when the UDA terminal is set to "H", the UDB terminal is set to "L".

[0450] One (ClkA1 terminal) of clock terminals (Clk terminals) is shared by gate signal output circuits **53a** and **53b** of each of the gate driver ICs **12** (**12a**, **12b**), and another one (ClkA2 terminal) of the clock terminals (Clk terminals) is shared by gate signal output circuits **53c** and **53d** of each of the gate drivers IC **12** (**12a**, **12b**). This configuration is intended to cause the gate signal output circuits **53a** and **53b** to operate at an identical clock and cause the gate signal output circuits **53c** and **53d** to operate at an identical clock in the gate driver IC **12b**, and to apply the wire-connection state of the gate driver IC **12b** (the connection state of the Clk terminal) to the gate driver IC **12a**.

[0451] Since the gate signal output circuits **53a**, **53b**, **53c**, and **53d** are operated at an identical clock in the gate driver IC **12a** according to the drive method illustrated with reference to FIGS. **35A** and **35B** etc., it is to be noted that these four gate signal output circuits **53** may be configured to operate at an identical clock by integrating the Clk terminals (ClkA1, ClkA2) into one.

[0452] In FIG. **35**, in the gate driver IC **12a**: a DatA1 terminal and an EnbA1 terminal are connected to the gate signal output circuit **53a**; and a DatA2 terminal and an EnbA2 terminal are connected to the gate signal output circuit **53b**. In the gate driver IC **12a**: a DatA3 terminal and an EnbA3 terminal are connected to the gate signal output circuit **53c**; and a DatA4 terminal and an EnbA4 terminal are connected to the gate signal output circuit **53d**.

[0453] In the gate driver IC **12b**: a DatB1 terminal and an EnbB1 terminal are connected to the gate signal output circuit **53a**; and a DatB2 terminal and an EnbB2 terminal are connected to the gate signal output circuit **53b**. In the gate driver IC **12b**: a DatB3 terminal and an EnbB3 terminal are connected to the gate signal output circuit **53c**; and a DatB4 terminal and an EnbB4 terminal are connected to the gate signal output circuit **53d**.

[0454] In FIG. **35**, the DatA1 terminal, the DatA2 terminal, the DatA3 terminal, and the DatA4 terminal of the gate driver IC **12a** are set to "H", and triggered by a clock input of the ClkA2 terminal, data with a circle mark is set to blocks **141** (A1, B1, C1, D1) of the gate driver IC **12a**. In addition, since the EnbA1 terminal, the EnbA2 terminal, the EnbA3 terminal, and the EnbA4 terminal of the gate driver IC **12a** are set to "H", an on voltage is applied to gate signal lines **17a**, **17b**, **17c**, and **17d** passing through pixels **16a** (the pixel row in which the pixels **16a** are positioned). An off voltage is applied to the gate signal lines **17** passing through the other pixels **16** (**16b**, **16c**, . . .).

[0455] The DatB1 terminal, the DatB2 terminal, the DatB3 terminal, and the DatB4 terminal of the gate driver IC **12b** are set to "H", and triggered by clock inputs of the ClkB1 and ClkB terminals, data with a circle mark is set to the blocks **141** (A1, B1, C1, D1) of the gate driver IC **12a**.

[0456] Since the EnbB1 terminal and the EnbB2 terminal of the gate driver IC **12b** are set to "H", and the EnbB3 terminal and the EnbB4 terminal are set to "L", an on voltage

is applied to the gate signal lines **17a** and **17b** of the pixels **16a**, and an off voltage is applied to the gate signal lines **17c** and **17d** passing through the pixels **16a**. An off voltage is applied to the gate signal lines **17** passing through the other pixels **16**.

[0457] With the setting states, the gate signal lines **17a** and **17b** passing through the pixels **16a** are subject to a both-side drive. The gate signal lines **17c** and **17d** passing through the pixels **16a** (the pixel row in which the pixels **16a** are positioned) are subject to a one-side drive. As described above, by using the identical gate driver ICs **12** and arranging the gate driver ICs **12a** and **12b** right and left of a display screen **25**, the present disclosure makes it possible to easily perform a both-side drive and a one-side drive. Here, the scanning direction of the gate driver ICs **12a** and **12b** are inverted.

[0458] The gate signal line **17a** is connected to switch transistors **11b** which apply a video signal. It is possible to turn on or off the switch transistors **11b** quickly by performing a both-side drive on the gate signal line **17a**. Furthermore, it is possible to turn on or off the switch transistors **11b** further quickly by performing a three-value drive of gate voltages on the gate signal output circuit **53a** which drives the gate signal lines **17a**. Accordingly, it is possible to realize excellent image (video) writing on the display screen **25**.

[0459] The switch transistors **11d** which function or act at the time of offset cancellation are connected to the gate signal line **17b**. It is possible to turn on or off the switch transistors **11d** quickly by performing a both-side drive on the gate signal line **17b**. Furthermore, it is possible to turn on or off the switch transistors **11b** further quickly by performing a three-value drive of gate voltages on the gate signal output circuit **53b** which drives the gate signal line **17a**. Accordingly, an excellent offset cancellation is performed.

[0460] Here, the voltage value of an on voltage (V_{on}) to be applied to an input terminal (V_{onB} terminal) for an on voltage of the gate signal output circuit **53b** is set to be higher than the voltage values of input terminals (V_{onA} , V_{onC} , V_{onD}) for the other on voltages. For example, the setting is performed such that a voltage $V_{onB} > a$ voltage V_{onA} is satisfied. Preferably, the V_{onB} voltage is set to be from +3 (V) to +15 (V) inclusive with respect to the voltage V_{onA} . Preferably, the voltage V_{onB} is set to be from +5 (V) to +10 (V) inclusive with respect to the voltage V_{onA} . It is possible to reduce the on resistances of the switch transistors **11d** by increasing the voltage v_{onB} (the on voltages of the switch transistors **11d**). Accordingly, it is possible to reduce a voltage fall between channels of the switch transistors **11d**, and to thus reduce an anode voltage V_{dd} and power consumed by the EL display (EL display panel).

[0461] As described above, according to the present disclosure, it is possible to arbitrarily set or apply an on voltage V_{on} of the gate signal output circuit **53**. In addition, it is possible to set the drive method of the gate signal output circuit **53** (a two-value drive of gate voltages, a three-value drive of gate voltages, etc.). Accordingly, it is possible to provide excellent image display, and to reduce power to be consumed by the EL display (EL display panel). Needless to say, the above embodiments are also applicable to other embodiments in the present disclosure. In addition, the above embodiments can of course be combined with other embodiments.

[0462] The gate signal line **17c** and the gate signal line **17d** drive switch transistors **11e** and **11c**. The switch transistors **11e** each have a function for applying a reference voltage (voltage V_{ref}) to the gate terminal of a corresponding one of

driver transistors **11a**. Application of the voltage V_{ref} does not need to be performed quickly. Accordingly, a one-side drive is sufficient for the gate signal line **17c**. The switch transistors **11c** each have a function for applying an initial voltage (voltage V_{ini}) to a second terminal of the corresponding driver transistor **11a**. Application of the voltage V_{ini} does not need to be performed quickly. Accordingly, a one-side drive is sufficient for the gate signal line **17d**.

[0463] As described above, the gate signal lines **17** (**17a**, **17b**) that require a both-side drive is driven by the gate driver IC **12a** and the gate driver IC **12b**. The gate signal lines **17** (**17c**, **17d**) that require a one-side drive is driven by the gate driver IC **12a**. It is possible to reduce the number of gate driver ICs **12b** by performing the drives or arranging the gate driver ICs **12**, and to thus reduce the cost of the EL display (EL display panel). As the gate driver IC **12a** and the gate driver IC **12b**, the gate driver ICs **12** having identical specifications (same kind ones) can be employed. Accordingly, it is possible to increase flexibility of the gate driver ICs **12**, and to reduce the cost for developing and designing the gate driver ICs **12**.

[0464] FIG. **36** is a diagram illustrating a state next to a state in FIG. **35**. In FIG. **35**, the $DatA1$ terminal, the $DatA2$ terminal, the $DatA3$ terminal, and the $DatA4$ terminal of the gate driver IC **12a** are set to "L", and triggered by clock inputs of the $ClkA1$ and $ClkA2$ terminals, data with a circle mark is set to the blocks **141** (**A1**, **B1**, **C1**, **D1**) of the gate driver IC **12a**.

[0465] Data items with a circle mark of the blocks **141** (**A1**, **B1**, **C1**, **D1**) of the gate driver IC **12a** are shifted in the shift registers, and are retained in blocks **141** (**A2**, **B2**, **C2**, **D2**). In addition, since the $EnbA1$ terminal, the $EnbA2$ terminal, the $EnbA3$ terminal, and the $EnbA4$ terminal of the gate driver IC **12a** are set to "H", an on voltage is applied to the gate signal lines **17a**, **17b**, **17c**, and **17d** passing through the pixels **16b** and driven by the gate driver IC **12a**. An off voltage is applied to the gate signal lines **17** passing through the other pixels **16** (**16a**, **16c**, . . .).

[0466] The $DatB1$ terminal, the $DatB2$ terminal, the $DatB3$ terminal, and the $DatB4$ terminal of the gate driver IC **12b** are set to "L", and clock inputs of the $ClkB1$ and $ClkB2$ terminals have not been provided from the state of FIG. **35**. Accordingly, the data items with a circle mark in the blocks **141** (**A1**, **B1**, **C1**, **D1**) are retained as they are in the gate driver IC **12a**.

[0467] The $EnbB1$ terminal and the $EnbB2$ terminal of the gate driver IC **12b** are set to "L", and the $EnbB3$ terminal and the $EnbB4$ terminal of the gate driver IC **12b** are set to "H". Accordingly, an off voltage is applied to the gate signal lines **17a** and **17b** passing through the pixels **16a**, and an on voltage is applied to the gate signal lines **17a** and **17b** passing through the pixels **16b** (the pixel row in which the pixels **16b** are positioned). An off voltage is applied to the gate signal lines **17** passing through the other pixels **16**.

[0468] With the setting states, the gate signal lines **17a** and **17b** passing through the pixels **16b** (the pixel row in which the pixels **16b** are positioned) are subject to a both-side drive. The gate signal lines **17c** and **17d** passing through the pixels **16b** (the pixel row in which the pixel **16b** is positioned) are subject to a one-side drive.

[0469] FIG. **37** is a diagram illustrating a state next to the state in FIG. **36**. In FIG. **37**, the $DatA1$ terminal, the $DatA2$ terminal, the $DatA3$ terminal, and the $DatA4$ terminal of the gate driver IC **12a** are set to "L", and triggered by clock inputs of the $ClkA1$ and $ClkA2$ terminals, data with a circle mark (off data) is set to the blocks **141** (**A1**, **B1**, **C1**, **D1**) of the gate

driver IC 12a. Data items with a circle mark of the blocks 141 (A2, B2, C2, D2) of the gate driver IC 12a are shifted in the shift registers, and are retained in blocks 141 (A3, B3, C3, D3). In addition, since the EnbA1 terminal, the EnbA2 terminal, the EnbA3 terminal, and the EnbA4 terminal of the gate driver IC 12a are set to “H”, an on voltage is applied to the gate signal lines 17a, 17b, 17c, and 17d passing through the pixels 16c and driven by the gate driver IC 12a. An off voltage is applied to the gate signal lines 17 passing through the other pixels 16 (16a, 16b, 16d . . .).

[0470] The DatB1 terminal, the DatB2 terminal, the DatB3 terminal, and the DatB4 terminal of the gate driver IC 12b are set to “L”, and a clock is input to the two ClkB1 and ClkB2 terminals. Accordingly, data items with a circle mark in the blocks 141 (A1, B1, C1, D1) of the gate driver IC 12b are shifted to the blocks 141 (A2, B2, C2, D2) and retained therein.

[0471] The EnbB1 terminal and the EnbB2 terminal of the gate driver IC 12b are set to “H”, and the EnbB3 terminal and the EnbB4 terminal of the gate driver IC 12b are set to “L”. Accordingly, an on voltage is applied to the gate signal lines 17a and 17b passing through the pixels 16c (the pixel row in which the pixels 16c are positioned), and an off voltage is applied to the gate signal lines 17a and 17b passing through pixels 16d. An off voltage is applied to the gate signal lines 17 passing through the other pixels 16.

[0472] With the setting states, the gate signal lines 17a and 17b passing through the pixels 16c (the pixel row in which the pixels 16c are positioned) are subject to a both-side drive. The gate signal lines 17c and 17d passing through the pixels 16c (the pixel row in which the pixels 16c are positioned) are subject to a one-side drive.

[0473] FIG. 38 is a diagram illustrating a state next to the state in FIG. 37. In FIG. 37, the DatA1 terminal, the DatA2 terminal, the DatA3 terminal, and the DatA4 terminal of the gate driver IC 12a are set to “L”, and triggered by a clock input of the ClkA2 terminal, data with a circle mark is set to the blocks 141 (A1, B1, C1, D1) of the gate driver IC 12a.

[0474] Data items with a circle mark of the blocks 141 (A3, B3, C3, D3) of the gate driver IC 12a are shifted in the shift registers, and are retained in the blocks 141 (A4, B4, C4, D4). In addition, since the EnbA1 terminal, the EnbA2 terminal, the EnbA3 terminal, and the EnbA4 terminal of the gate driver IC 12a are set to “H”, an on voltage is applied to the gate signal lines 17a, 17b, 17c, and 17d passing through the pixels 16d (the pixel row in which the pixels 16d are positioned) and driven by the gate driver IC 12a. An off voltage is applied to the gate signal lines 17 passing through the other pixels 16 (16a, 16b, 16c, 17e . . .).

[0475] The DatB1 terminal, the DatB2 terminal, the DatB3 terminal, and the DatB4 terminal of the gate driver IC 12b are set to “L”, and no clocks have been input to the ClkB1 and ClkB2 terminals have not been provided from the state of FIG. 29. Accordingly, the data items with a circle mark in the blocks 141 (A2, B2, C2, D2) are retained as they are in the gate driver IC 12b.

[0476] The EnbB1 terminal and the EnbB2 terminal of the gate driver IC 12b are set to “L”, and the EnbB3 terminal and the EnbB4 terminal of the gate driver IC 12b are set to “H”. Accordingly, an on voltage is applied to the gate signal lines 17a and 17b passing through the pixels 16d, and an off voltage is applied to the gate signal lines 17a and 17b passing through the pixels 16c. An off voltage is applied to the gate signal lines 17 passing through the other pixels 16.

[0477] With the setting states, the gate signal lines 17a and 17b passing through the pixels 16d (the pixel row in which the pixels 16d are positioned) are subject to a both-side drive. The gate signal lines 17c and 17d passing through the pixels 16d (the pixel row in which the pixels 16d are positioned) are subject to a one-side drive.

[0478] In each of FIGS. 35 to 39, only a data item with a circle mark is retained in one of the shift registers 51 of some of the gate signal output circuits 53 in one of the gate drivers IC 12. However, as described in the earlier embodiments, the present disclosure is not limited thereto.

[0479] FIG. 39 is a diagram illustrating an embodiment in which a plurality of data items with a circle mark or consecutive data items with a circle mark are retained and shifted in some of the shift registers 51 in the gate signal output circuit 53. FIG. 39 illustrates, as examples, the gate signal output circuits 53c and 53d of the gate driver IC 12a.

[0480] In FIG. 39, each of the Data3 terminal and the Data4 terminal of the gate driver IC 12a is set to “L” or “H”, and triggered by a clock input of the ClkA2 terminal, a data item with or without a circle mark is set to each of the blocks 141 (C1, D1) of the gate driver IC 12a. Data items with a circle mark are sequentially retained and shifted in the blocks 141 of the shift registers 51 by inputting a clock Clk with the Dat terminals kept in the “H” state. Data items without a circle mark are sequentially retained and shifted in the blocks 141 of the shift registers 51 by inputting a clock Clk with the Dat terminals kept in the “L” state.

[0481] FIG. 39 illustrates a state in which data items with a circle mark are sequentially retained in the blocks 141 (C2, C3, C4, D2, D3, D4) of the gate signal output circuits 53c and 53d by means of the clock Clk was input three times with the Dat terminals kept in the “H” state. Accordingly, an on voltage is output or applied to the gate signal lines 17c and 17d of the pixels 16b, 16c, and 16d.

[0482] Although this embodiment has been described taking a pixel configuration in FIG. 5 as an example, the present disclosure is not limited thereto. For example, a pixel configuration illustrated in FIG. 40 is also possible. Needless to say, this embodiment is also applicable to other embodiments in the present disclosure. In addition, this embodiment can of course be combined with other embodiments.

[0483] As in FIG. 5, in the embodiment of the EL display illustrated in FIG. 40, the four signal lines 17 that are the gate signal line 17a, the gate signal line 17b, the gate signal line 17c, and the gate signal line 17d pass through each of the pixels 16. The gate signal output circuit 53a of the gate driver IC 12a is arranged for the gate signal line 17a, and the gate signal output circuit 53b of the gate driver IC 12a is arranged for the gate signal line 17b. The gate signal output circuit 53c of the gate driver IC 12a is arranged for the gate signal line 17c, and the gate signal output circuit 53d of the gate driver IC 12a is arranged for the gate signal line 17d.

[0484] In each pixel 16 in FIG. 40, a first terminal of the P-channel driver transistor 11a is connected to an electrode or a line of an anode voltage Vdd, and a second terminal thereof is connected to a first terminal of the switch transistor 11d. The gate terminal of the switch transistor 11d is connected to the gate signal line 17b. The second terminal of the switch transistor 11d is connected to a first terminal of the EL element 15. A second terminal of the EL element 15 is connected to an electrode or a line to which a cathode voltage Vss is applied.

[0485] In FIG. 40, the transistors are P-channel transistors, but this is a non-limiting example and the transistors may be N-channel transistors. In addition, one or more P-channel transistors and one or more N-channel transistors may coexist.

[0486] A first terminal of the switch transistor 11e is connected to an electrode or a line to which a reset voltage Va is applied, and a second terminal of the switch transistor 11e is connected to the gate terminal of the driver transistor 11a. The gate terminal of the switch transistor 11e is connected to the gate signal line 17c.

[0487] A first terminal of the switch transistor 11b which provides the pixel 16 with a video signal is connected to the source line 18, and a second terminal of the switch transistor 11b is connected to a first terminal of a second capacitor 19b. A second terminal of the second capacitor 19b is connected to the gate terminal of the driver transistor 11a. The gate terminal of the switch transistor 11b is connected to the gate signal line 17a.

[0488] A first terminal of a first capacitor 19a is connected to an anode voltage Vdd, a second terminal of the first capacitor 19a is connected to the first terminal of the second capacitor 19b of the gate terminal of the driver transistor 11a.

[0489] A first terminal of the switch transistor 11c is connected to the gate terminal of the driver transistor 11a, and a second terminal of the switch transistor 11c is connected to a second terminal of the driver transistor 11a. The gate terminal of the switch transistor 11c is connected to the gate signal line 17b.

[0490] Multiple gates (at least dual gates) are used for at least one of the switch transistors 11b and 11e in combination with an LDD structure, which makes it possible to reduce off leak and realize excellent contrast and offset cancellation. In addition, an excellent high luminance display and image display can be obtained.

[0491] The gate signal line 17a and the gate signal line 17c are driven at both sides by the gate driver IC 12a and the gate driver IC 12b. In addition, the gate signal line 17c and the gate signal line 17d are driven at one side by the gate driver IC 12a.

[0492] In FIG. 40, a both side drive is performed on the gate signal line 17a connected to the switch transistor 11b which applies a video signal to the pixel 16. In addition, a both side drive is performed on the gate signal line 17b connected to the switch transistor 11c which performs an operation or control at the time of offset cancelling of the driver transistor 11a.

[0493] Needless to say, the drive methods according to the present disclosure are applicable also to the pixel configuration in FIG. 40 etc. This embodiment is of course also applicable to other embodiments in the present disclosure. In addition, this embodiment can of course be combined with other embodiments.

[0494] FIG. 40 illustrates details of the configuration or structure of the gate driver ICs 12 (12a, 12b) in FIG. 35 etc.

[0495] In FIG. 40, an output buffer 52 is arranged or formed at the output side of the gate signal output circuit 53. A terminal (Buf terminal) for switching or setting buffer performances is connected or arranged to the output buffer 52. The Buf terminal is the terminal for setting or switching the buffer performances. In the embodiment illustrated in FIG. 40, each of Buf terminals can set in three bits representing any of eight combinations of buffer performances as the cube-of-2 combinations. In other words, the buffer performances can be set at eight levels ranging from weak to strong.

[0496] Each of control terminals (Enb, Dat, Clk) are arranged or formed at at least two positions in the gate signal output circuit 53. SEL terminals are arranged between driver output terminals 72 and the Von terminals.

[0497] An output from the gate signal output circuit 53 is output from a connection terminal 71 after passing through the driver output terminal 72 of the gate driver IC 12 and a COF line 74. A gate signal line 17 is connected to the connection terminal 71.

[0498] Control signals such as Dat1, Dat2, Enb1, Enb2, Clk1, Clk2 etc. are bi-directional signals. Accordingly, data can be transferred in a direction from connection terminals 75a to 75b, and also in a direction of connection terminals 75b to 75a. The data transfer direction is switched by logic control performed by a transfer direction switching terminal (not illustrated).

[0499] The gate driver IC 12 includes a switch circuit 161. The switch circuit 161 is a switch circuit for realizing three-value drives of gate voltages in FIG. 20B, and two-value drives of gate voltages in FIG. 20A.

[0500] The three-value drive of gate voltages illustrated in FIG. 20B is realized by means of the switch circuit 161 switching outputs in the following listed order from a voltage Von via a voltage Voff2 to a voltage Voff1. The two-value drive of gate voltages illustrated in FIG. 20A is realized by means of the switch circuit 161 switching outputs in the following listed order from the voltage Von to the voltage Voff1.

[0501] Needless to say, this embodiment is also applicable to other embodiments in the present disclosure. In addition, this embodiment can of course be combined with other embodiments.

[0502] FIG. 41 is a diagram illustrating gamma circuits of a source driver IC (circuit) 14 of the EL display (EL display panel) according to the present disclosure. The gamma circuits comprise independent red (R), green (G), and blue (B) gamma circuits each outputs signals of a grayscale representing 2^{10} (1024) levels of brightness.

[0503] Each of the R, G, and B gamma circuits includes a ladder resistor provided with eight taps (Vi0, Vi1, Vi2, Vi3, Vi4, Vi5, Vi6, and Vi7) each connected to a terminal of the source driver IC (circuit) 14.

[0504] The tap position of Vi0 is a minimum grayscale of video signals (a minimum voltage value or an origin). The tap position of Vi7 is a maximum grayscale of video signals (a maximum voltage value).

[0505] The tap position of Vi1 corresponds to a voltage value equal to $1/1024$ of a video signal amplitude or a voltage value approximate thereto.

[0506] The tap position of Vi2 corresponds to a voltage value equal to $1/36$ of the video signal amplitude or a voltage value approximate thereto.

[0507] The tap position of Vi3 corresponds to a voltage value equal to $1/12$ of the video signal amplitude or a voltage value approximate thereto.

[0508] The tap position of Vi4 corresponds to a voltage value equal to $1/6$ of the video signal amplitude or a voltage value approximate thereto.

[0509] The tap position of Vi5 corresponds to a voltage value equal to $1/3$ of the video signal amplitude or a voltage value approximate thereto.

[0510] The tap position of Vi6 corresponds to a voltage value equal to $2/3$ of the video signal amplitude or a voltage value approximate thereto.

[0511] A gamma curve can be set or changed as illustrated in FIG. 42 by applying or setting a voltage to each of the tap positions (Vi0 to Vi7) each intended to receive an input or (setting) of a voltage. Each gamma circuit of the source driver IC 14 applies a voltage to each of Vi0, Vi1, and Vi7 terminals. Preferably, no voltage is applied to the other terminals in order to retain linearity of the video signals. It is preferable that the voltages to be applied to the Vi1 and Vi7 terminals of red (R), green (G), and blue (B) can be independently set, and a single Vi0 terminal is shared between the RGB gamma circuits.

[0512] The amplitude of the video signals can be changed by changing or modifying the tap positions (Vi0 to Vi7) at which the voltages are to be input (set). For example, as illustrated in FIG. 9, the amplitude of the video signals can be changed by changing Vi1 to Vi1' and Vi7 to Vi7'. A gamma curve between Vi1 to Vi7 can be linear by using Vi2 to Vi6 in an open state (in which no voltage is applied).

[0513] When the voltages Vi1 and Vi7 are changed, the amplitude of the video signals is also changed. When the amplitude of the video signals is changed, output voltages (on voltages and off voltages) of the gate driver ICs 12 are changed. As described earlier, each gate driver IC 12 of the present disclosure can change or set an on voltage (Von) and off voltages (Voff1, Voff2). Accordingly, for example, a combination with the source driver IC (circuit) 14 in FIG. 14 provides synergy effects. FIG. 14 is a block diagram of the source driver IC 14 in the EL display according to the present disclosure.

[0514] According to the present disclosure, the switch transistors 11 which apply video signals to the pixels 16 perform a both-side drive.

[0515] In addition, the switch transistors 11 which act or contribute at the time of offset cancellation perform a both-side drive. On the other hand, a one-side drive is sufficient for some of the switch transistors (e.g. switch transistors 11d) which do not affect image display even if an on or off delay occurred.

[0516] As described above, according to the present disclosure, one of a both-side drive or a one-side drive is selected based on on or off time required for the transistors 11 of the pixels 16 or based on a load capacity of each gate signal line 17. Here, a three-value drive of gate voltages or a two-value drive of gate voltages is selected.

[0517] As described above, relationships between the video for image display and (i) rise or fall times of gate signal lines or (ii) on or off times of the transistors 11 are important. In other words, it is important that relationships between video signal systems and control systems of the switch transistors 11 are set or adjusted to the optimum ones.

[0518] For this reason, according to the present disclosure, a delay circuit 485 is formed or provided in the source driver IC 14 as illustrated in FIG. 14. The delay circuit 485 is a circuit for adjusting or setting output timings for a video signal Vs using each of source signal lines Y1 to Y720 or blocks of the source signal lines Y1 to Y720.

[0519] In FIG. 14, a SEL (1:0) for switching shift directions is applied to a shift register 483. Start pulses DIO1 and DIO2 of the shift register 483 are applied.

[0520] Ten combinations of comparator input signals LV0A, LV0B to LV9A, LV9B are output to a digital receiver 481. A video signal from the digital receiver 481 is latched in

a latch circuit 484, and retained in a period of 1H (one horizontal scanning period) or 2H (two horizontal scanning periods).

[0521] A video signal from the latch circuit 484 is input to the delay circuit 485, and the delay circuit 485 delays the video signal according to a preset action or a control method.

[0522] An output of the delay circuit 485 is applied to a digital-analog (DA) conversion circuit 486. The DA conversion circuit 486 outputs an analog voltage on which gamma conversion was performed, according to voltages VXi0 to VXi7 (X: R, G, or B) set in gamma setting circuits 482.

[0523] An output from the DA conversion circuit 486 is input to a buffer circuit 487, and is output to the source signal lines Y1 to Y720 via a switch circuit 488. The buffer circuit 487 is configured to have settings of a plurality of buffer performances such as Strong, Middle, and Weak.

[0524] The switch circuit 488 is a switch circuit capable of selecting one of a precharge voltage or a video signal voltage. When a precharge voltage is selected, the precharge voltage is applied to a corresponding one of the source signal lines Y1 to Y720, and electric charge accumulated in the corresponding one of the source signal lines Y1 to Y720 is forcibly charged or released.

[0525] It is preferable that gamma characteristics be set to be linear as illustrated in FIG. 43 in order to facilitate settings of delay times of video signals in the delay circuit 485, according to the present disclosure. In order to make gamma characteristics to be linear, a predetermined voltage is applied to each of Tap for a voltage VXi1 corresponding to Level 1 in a grayscale and Tap for a voltage VXi7 corresponding to Level 1023 in the grayscale, and no voltage is applied to taps (for voltages VXi2 to VXi6) between Taps for the voltage VXi1 and a voltage VXi7. Here, a voltage common among RGB is applied to a terminal for a voltage VXi0. In FIG. 43, Levels 1 and 1023 in the grayscale are changed or set, and the other voltage input taps are not connected. Accordingly, input levels and output levels in the grayscale are linear between Levels 1 and 1023 in the grayscale. In other words, there is no gamma curve, and if an input level is the hundredth one, an output level is also the hundredth one.

[0526] Voltage settings to the terminals for the voltages VXi0 to VXi7 (X denotes R, G, or B) can be performed from outside the source driver IC (circuit) 14. A gamma curve can be arbitrarily set by setting voltages.

[0527] Needless to say, this embodiment is also applicable to other embodiments in the present disclosure. In addition, this embodiment can of course be combined with other embodiments.

[0528] The present disclosure has been explained taking EL display panels as examples in this specification, but the technical ideas of the present disclosure are not limited to the EL display panels. For example, the matters relating to the methods for the COFs in the present disclosure are of course applicable to LCDs etc.

[0529] Details (or part of the details) in the above embodiment described with reference to the drawings are applicable to various kinds of electronic devices. More specifically, the details are applicable to display parts of such electronic devices.

[0530] Examples of such electronic devices include: video cameras; digital cameras; goggles type displays; navigation systems; audio reproduction devices (car audio devices, audio compositions, etc.); computers; gaming machines; mobile information terminals (mobile computers, mobile

telephones, mobile gaming machines, or electronic book readers, etc.); image reproduction devices with recording media (specifically, devices capable of reproducing images recorded on the recording media such as digital versatile discs (DVDs) and having a display on which the images can be displayed).

[0531] FIG. 45 is a display including a casing 492, a stand 493, and an EL display (EL display panel) according to the present disclosure. The display illustrated in FIG. 45 has a function for displaying various kinds of information (still images, videos, text images, etc.). Functions of the display illustrated in FIG. 45 are not limited thereto, and can have various functions.

[0532] FIG. 46 is a camera including a shutter 501, a view finder 502, and a cursor 503. The camera illustrated in FIG. 5 has a function for capturing still images. The camera illustrated also has a function for capturing videos. Functions of the display illustrated in FIG. 5 are not limited thereto, and can have various functions.

[0533] FIG. 47 illustrates a computer including a keyboard 511 and a touch pad 512. The computer illustrated in FIG. 47 has a function for displaying various kinds of information (still images, videos, text images, etc.) on a display part. Functions of the computer illustrated in FIG. 47 are not limited thereto, and can have various functions.

[0534] This applies to other drawings. The matters and content illustrated in the drawings or described in this embodiment of the specification according to the present disclosure are also applicable to other embodiments. The EL display panel illustrated in the drawings or described in this embodiment disclosed herein is applicable to EL displays according to the present disclosure.

[0535] For example, needless to say, as an EL display 491 of a note type personal computer in FIG. 47, one of the EL displays (EL display panels) illustrated in the drawings or described in this embodiment of the present disclosure can be employed, to comprise an information apparatus.

[0536] In the specification and drawings, generic names may be used to refer to the identical, similar, or related ones. For example, when both gate signal lines 17 and source signal lines 18 are described at the same time, these lines may be described or illustrated as signal lines 17 (18). A glass substrate 48 and a sealing substrate 30 may be referred to as substrates 30 (48).

[0537] Parts assigned with the same numbers or symbols have identical or similar shapes, materials, functions, relevant matters, perform identical or similar actions, or provide identical or similar effects.

[0538] In the embodiments of the specification and the drawings, matters, structures, effects etc. as described in other embodiments of the specification and the drawings are applicable unless otherwise specified, and thus the identical or similar descriptions etc. are not repeated.

[0539] The details illustrated in the drawings etc. can be combined with other embodiments etc. even when no such indication is provided. For example, it is possible to configure an information display device as illustrated in FIG. 45, 46, or 47 by adding a touch panel etc. on the EL display panel as illustrated in FIG. 1 or 2.

[0540] In this disclosure, for convenience' sake, configurations with only a panel are normally referred to as EL display panels, and configurations including a peripheral circuit such as a COF 22g as illustrated in FIG. 48 are referred to as EL displays. The EL display panels according to the present

disclosure may conceptually be panel modules, and the the EL displays according to the present disclosure may conceptually be system apparatuses such as information apparatuses. The EL display panels may conceptually be the system apparatuses such as information apparatuses in a broad sense.

[0541] Although the COF 22g or the gate driver ICs 12 have been described in each of the embodiments of the present disclosure, the technical idea of the present disclosure is of course also applicable to the COF 22s or the source driver IC 14 in the embodiment.

[0542] Accordingly, the matters described in the specification are of course applicable to the COF 22s or the source driver IC 14, and also to the EL display including the same. This embodiment is of course also applicable to other embodiments in the present disclosure. In addition, this embodiment can be of course combined with other embodiments.

[0543] Although the driver transistors 11a and the switch transistors 11 (11b, 11c, 11d, 11e) have been described as thin-film transistors in the present disclosure, the present disclosure is not limited to the thin-film transistors. Thin-film diodes (TFD) or the like can be used to configure the same.

[0544] Such thin-film elements are non-limiting examples, and transistors formed on a silicon wafer are also possible. For example, transistors may be firstly formed on a silicon wafer, then peeled off from the silicon wafer, and finally printed on a glass board.

[0545] As a matter of course, the transistors 11 may be FETs, MOS-FETs, MOS transistors, or bi-polar transistors.

[0546] It is preferable that the transistors 11 according to the present disclosure be configured to have a lightly doped drain (LDD), irrespective of whether each transistor 11 is an N-channel transistor or a P-channel transistor.

[0547] Each transistor 11 may be made any of a high temperature polysilicon (HTPS), a low temperature polysilicon (LTPS), a continuous grain silicon (CGS), a transparent amorphous oxide semiconductor (TAOS, IZO), an amorphous silicon (AS), or an infrared RTA.

[0548] In FIG. 49, all of transistors included in pixels are configured as P-channel transistors. However, the present disclosure is not limited only to the configuration in which the transistors 11 included in the pixels are P-channel transistors. Only N-channel transistors may be used in the configuration. Alternatively, both of N-channel transistors and P-channel transistors may be used in the configuration. For example, the driver transistors 11a may be configured with both one or more P-channel transistors and one or more N-channel transistors.

[0549] Preferably, the transistors have a top gate structure. With the top gate structure, parasitic capacitance is reduced. This is because a gate electrode pattern of the top gate serves as a light blocking layer which blocks light emitted from EL elements 15, to reduce operation errors by the transistors and off-leak currents.

[0550] It is preferable to perform a process for enabling employment of copper lines or copper alloy lines as line materials for either gate signal lines or source signal lines, or both of gate signal lines and source signal lines. This is because line resistances of the signal lines can be reduced, which makes it possible to realize a larger EL display panel.

[0551] It is preferable that gate signal lines 17 driven (controlled) by a gate driver IC (circuit) 12 be configured to have a low impedance. Accordingly, the same applies to the configuration or structure of gate signal lines 17.

[0552] In particular, it is preferable that a low temperature polysilicon be employed. With the low temperature polysilicon, transistors are configured to have a top gate structure and thus have a small parasitic capacitance, P-channel transistors can be generated, and a copper wiring or copper alloy wiring process can be used. Preferably, a Tu-Cu-Ti three layer structure be employed for the copper lines.

[0553] In the case of a transparent amorphous oxide (TAOS) semiconductor, an Mo-Cu-Mo three layer structure be employed.

[0554] The thickness, size, etc. of some part are magnified or reduced to simplify explanation. This applies to the other drawings.

[0555] The panel board 31 described as a glass substrate may be a panel board 31 formed using a silicon wafer. Alternatively, the panel board 31 may be a panel board 31 formed using a metal substrate, a ceramic substrate, a plastic sheet (plate), or the like.

[0556] The materials and configurations for a sealing substrate 30 are similar to those for the panel board 31. In order to provide excellent heat dissipation, each of the sealing substrate 30 and the panel board 31 may of course be a sealing substrate 30 and a panel board 31 made of sapphire glass, or the like.

[0557] Needless to say, the embodiment is also applicable to other embodiments in the present disclosure. In addition, this embodiment can be of course combined with other embodiments.

[0558] By configuring the information devices or the like in FIGS. 45 and 46 to have the EL display (EL display panel) described in any of the above embodiments on the display part of this embodiment or perform the drive method, high quality images can be provided while reducing the cost. Tests and adjustments can be easily performed.

[0559] The embodiments can be performed in arbitrary combination with other embodiments.

INDUSTRIAL APPLICABILITY

[0560] The present disclosure makes it possible to reduce the number of control lines which are formed in serial connection on COFs can be reduced, and to provide EL displays with an excellent yield at low cost.

REFERENCE SIGNS LIST

- | | | | |
|--------|-----------------------|--------|---|
| [0561] | 11 Transistor | [0580] | 17a Gate signal line |
| [0562] | 11a Driver transistor | [0581] | 17b Gate signal line |
| [0563] | 11b Transistor | [0582] | 17c Gate signal line |
| [0564] | 11c Transistor | [0583] | 17d Gate signal line |
| [0565] | 11d Transistor | [0584] | 18 Gate signal line |
| [0566] | 11e Transistor | [0585] | 19 Capacitor |
| [0567] | 12 Gate driver IC | [0586] | 19a Capacitor |
| [0568] | 12a Gate driver IC | [0587] | 19b Capacitor |
| [0569] | 12b Gate driver IC | [0588] | 22 COF |
| [0570] | 14 Gate driver IC | [0589] | 22 Flexible board |
| [0571] | 15 EL element | [0590] | 22a1 Flexible board |
| [0572] | 16 Pixel | [0591] | 22a2 Flexible board |
| [0573] | 16W Pixel | [0592] | 22g Flexible board |
| [0574] | 16a Pixel | [0593] | 22c COF |
| [0575] | 16b Pixel | [0594] | 25 Display screen |
| [0576] | 16c Pixel | [0595] | 30 Sealing substrate |
| [0577] | 16d Pixel | [0596] | 31 Panel board |
| [0578] | 16e Pixel | [0597] | 33 Color filter |
| [0579] | 17 Gate signal line | [0598] | 34 Insulation film |
| | | [0599] | 35 Display screen |
| | | [0600] | 36 Light blocking film |
| | | [0601] | 37 Connection part |
| | | [0602] | 38 Light scattering film |
| | | [0603] | 40 Anode electrode |
| | | [0604] | 43 Cathode electrode |
| | | [0605] | 44 Low resistance line |
| | | [0606] | 47 Bonding layer |
| | | [0607] | 48 Glass substrate |
| | | [0608] | 49 EL display panel |
| | | [0609] | 51 Shift register |
| | | [0610] | 51a Shift register |
| | | [0611] | 51b Shift register |
| | | [0612] | 51c Shift register |
| | | [0613] | 51d Shift register |
| | | [0614] | 52 Output buffer |
| | | [0615] | 53 Gate signal output circuit |
| | | [0616] | 53a Gate signal output circuit |
| | | [0617] | 53b Gate signal output circuit |
| | | [0618] | 53c Gate signal output circuit |
| | | [0619] | 53d Gate signal output circuit |
| | | [0620] | 54 Array connection line |
| | | [0621] | 71 Connection terminal (second connection part) |
| | | [0622] | 72 Driver output terminal (control terminal) |
| | | [0623] | 73 Driver input terminal (driver terminal) |
| | | [0624] | 73a Driver input terminal (driver terminal) |
| | | [0625] | 73a1 Driver input terminal |
| | | [0626] | 73a2 Driver input terminal |
| | | [0627] | 73b Driver input terminal (driver terminal) |
| | | [0628] | 73b1 Driver input terminal |
| | | [0629] | 73b2 Driver input terminal |
| | | [0630] | 74 COF line |
| | | [0631] | 74a COF line (serial connection line) |
| | | [0632] | 74a1 COF line |
| | | [0633] | 74a2 COF line |
| | | [0634] | 74b COF line (serial connection line) |
| | | [0635] | 74b2 COF line |
| | | [0636] | 74c COF line (serial connection line) |
| | | [0637] | 74c1 COF line |
| | | [0638] | 74d COF line (terminal connection line) |
| | | [0639] | 74e COF line (terminal connection line) |
| | | [0640] | 74f COF line |
| | | [0641] | 74f2 COF line |
| | | [0642] | 75 Connection terminal |
| | | [0643] | 75a Connection terminal (first connection part) |

- [0644] 75b Connection terminal (third connection part)
 [0645] 75c Connection terminal (gate signal connection part)
 [0646] 76 Operation terminal (gate signal output terminal)
 [0647] 76a Operation terminal
 [0648] 76b Operation terminal
 [0649] 91 Panel line
 [0650] 91a Panel line
 [0651] 91a1 Panel line
 [0652] 91a2 Panel line
 [0653] 91b Panel line
 [0654] 91b1 Panel line
 [0655] 91c Panel line
 [0656] 101 Voltage and signal input unit
 [0657] 141 Block
 [0658] 161 Switch circuit
 [0659] 261 Input control line
 [0660] 261a Input control line
 [0661] 261b Input control line
 [0662] 262 Internal line
 [0663] 262a Internal line
 [0664] 262b Internal line
 [0665] 262c Internal line
 [0666] 271 Bi-directional buffer
 [0667] 271a Bi-directional buffer
 [0668] 271b Bi-directional buffer
 [0669] 481 Digital receiver
 [0670] 482 Gamma setting circuit
 [0671] 483 Shift register
 [0672] 484 Latch circuit
 [0673] 485 Delay circuit
 [0674] 486 DA converter circuit
 [0675] 487 Buffer circuit
 [0676] 488 Switch circuit
 [0677] 491 Display device
 [0678] 492 Casing
 [0679] 493 Stand
 [0680] 501 Shutter
 [0681] 502 View finder
 [0682] 503 Cursor
 [0683] 511 Keyboard
 [0684] 512 Touch pad
 [0685] a Trajectory
 [0686] b Trajectory
 [0687] c Trajectory
 [0688] A1 Block
 [0689] A2 Block
 [0690] A3 Block
 [0691] A4 Block
 [0692] AB Block
 [0693] B1 Block
 [0694] B2 Block
 [0695] C1 Operation terminal
 [0696] C2 Block
 [0697] C6 Operation terminal
 [0698] C7 Operation terminal
 [0699] C8 Operation terminal
 [0700] Clk Clock
 [0701] Clk2 Clock data
 [0702] ClkB1 Clock
 [0703] ClkB2 Clock
 [0704] Dat Data
 [0705] DIO1 Start pulse
 [0706] E1 Voltage circuit
 [0707] E2 Voltage circuit
 [0708] Enb Enable
 [0709] EnbB1 Enable terminal
 [0710] EnbB2 Enable terminal
 [0711] LV0A Comparator input signal
 [0712] RTA Infrared rays
 [0713] S1a Driver input terminal
 [0714] S2b Driver input terminal
 [0715] S3b Driver input terminal
 [0716] Ta Application period
 [0717] Tb Application period
 [0718] Tc Period
 [0719] Va Reset voltage
 [0720] Vs Video signal
 [0721] Vdd Anode voltage
 [0722] Vcc Logic voltage
 [0723] Vini Initial voltage
 [0724] Voff Off voltage
 [0725] Voff1 Voltage application terminal
 [0726] Von On voltage
 [0727] VonA On voltage
 [0728] VonB On voltage
 [0729] Vss Cathode voltage
 [0730] Vgg Ground voltage
 [0731] Vref Reset voltage
 [0732] Y1 Source signal line
1. An EL display comprising:
 - a panel board including a display screen on which pixels each including an EL element are arranged in a matrix; gate signal lines arranged on a per pixel row basis; source signal lines arranged on a per pixel column basis; gate driver circuits mounted on a flexible board; and a source driver circuit which outputs a video signal to the source signal lines,
 - wherein each of the gate driver circuits includes gate signal output terminals, driver terminals, and control terminals, first connection parts, gate signal connection parts, second connection parts, and third connection parts are arranged on a side of the flexible board,
 - the flexible board includes (i) terminal connection lines which connect the gate signal output terminals and the gate signal connection parts, (ii) terminal connection lines which connect the control terminals and the second connection parts, and (iii) serial connection lines which connect the first connection parts, the driver terminals, and the third connection parts,
 - the control terminals are arranged between the gate signal output terminals and the driver terminals, and panel lines formed on the panel board are connected to the second connection parts.
 2. The EL display according to claim 1, wherein each of the gate driver circuits includes a plurality of shift register circuits.
 3. The EL display according to claim 1, wherein at least one of the driver terminals is a terminal which sets a signal mode to be output from the one of the gate signal output terminals, the signal mode is one of (i) a first signal mode in which an on voltage and a first off voltage are applied or (ii) a second signal mode in which an on voltage, a first off voltage, and a second off voltage are applied, and the one of the first signal mode or the second signal mode is selected by the terminal which sets the signal mode.

4. The EL display according to claim 1, wherein a voltage to be applied to the panel lines connected to the second connection parts is either a logic setting voltage or a voltage to be output from the one of the gate signal output terminals.
5. The EL display according to claim 1, wherein each of the pixels is passed through by the gate signal lines, n being an integer of 2 or larger, and each of the gate driver circuits includes n shift register circuits.
6. The EL display according to claim 1, wherein a plurality of gate signal output circuits are formed in each of the gate driver circuits, and an independent voltage V_{on} is applied to each of the gate signal output circuits.
7. The EL display according to claim 1, a first one of the gate driver circuits is arranged on a first side of the display screen, and a second one of the gate driver circuits is arranged on a second side of the display screen.
8. An EL display comprising, a panel board including a display screen on which pixels each including an EL element are arranged in a matrix; gate signal lines arranged on a per pixel row basis; source signal lines arranged on a per pixel column basis; gate driver circuits mounted on a flexible board; and a source driver circuit which outputs a video signal to the source signal lines, wherein each of the gate driver circuits includes gate signal output terminals, first driver terminals, second driver terminals, and control terminals, first connection parts, gate signal connection parts, second connection parts, and third connection parts are arranged on a side of the flexible board, the flexible board includes (i) terminal connection lines which connect the gate signal output terminals and the gate signal connection parts, (ii) terminal connection lines which connect the control terminals and the second connection parts, and (iii) serial connection lines which connect the first connection parts, the driver terminals, and the third connection parts, the control terminals are arranged either between the gate signal output terminals and the first driver terminals or between the gate signal output terminals and the second driver terminals, and panel lines formed on the panel board are connected to the second connection parts, and the second connection parts and the control terminals are connected with the terminal connection lines.
9. The EL display according to claim 8, wherein each of the gate driver circuits includes a plurality of shift register circuits.
10. The EL display according to claim 8, wherein at least one of the driver terminals is a terminal which sets a signal mode to be output from the one of the gate signal output terminals, the signal mode is one of (i) a first signal mode in which an on voltage and a first off voltage are applied or (ii) a second signal mode in which an on voltage, a first off voltage, and a second off voltage are applied, and the one of the first signal mode or the second signal mode is selected by the terminal which sets the signal mode.
11. The EL display according to claim 8, wherein a voltage to be applied to the panel lines connected to the second connection parts is either a logic setting voltage or a voltage to be output from the one of the gate signal output terminals.
12. The EL display according to claim 8, wherein each of the pixels is passed through by the gate signal lines, n being an integer of 2 or larger, and each of the gate driver circuits includes n shift register circuits.
13. The EL display according to claim 8, wherein a plurality of gate signal output circuits are formed in each of the gate driver circuits, and an independent voltage V_{on} is applied to each of the gate signal output circuits.
14. An EL display comprising, a panel board including a display screen on which pixels each including an EL element are arranged in a matrix; gate signal lines arranged on a per pixel row basis; source signal lines arranged on a per pixel column basis; gate driver circuits mounted on a flexible board; and a source driver circuit which outputs a video signal to the source signal lines, wherein each of the gate driver circuits includes gate signal output terminals, third driver terminals, fourth driver terminals, and control terminals, first connection parts, gate signal connection parts, second connection parts, and third connection parts are arranged on a side of the flexible board, the flexible board includes (i) terminal connection lines which connect the gate signal output terminals and the gate signal connection parts, (ii) terminal connection lines which connect the control terminals and the second connection parts, (iii) terminal connection lines which connect the first connection parts and the third driver terminals, and (iv) terminal connection lines which connect the third driver terminals and the third connection parts, and the third driver terminals and the fourth driver terminals are connected by lines formed in each of the gate driver circuits.
15. The EL display according to claim 14, wherein each of the gate driver circuits includes a plurality of shift register circuits.
16. The EL display according to claim 14, wherein a bi-directional buffer circuit is arranged at a point on a line formed in each of the gate driver circuits.
17. The EL display according to claim 14, wherein at least one of the driver terminals is a terminal which sets a signal mode to be output from the one of the gate signal output terminals, the signal mode is one of (i) a first signal mode in which an on voltage and a first off voltage are applied or (ii) a second signal mode in which an on voltage, a first off voltage, and a second off voltage are applied, and the one of the first signal mode or the second signal mode is selected by the terminal which sets the signal mode.
18. The EL display according to claim 14, wherein each of the pixels is passed through by the gate signal lines, n being an integer of 2 or larger, and each of the gate driver circuits includes n shift register circuits.
19. The EL display according to claim 14, wherein a plurality of gate signal output circuits are formed in each of the gate driver circuits, and

an independent voltage V_{on} is applied to each of the gate signal output circuits.

20. The EL display according to claim **14**,
a first one of the gate driver circuits is arranged on a first side of the display screen, and a second one of the gate driver circuits is arranged on a second side of the display screen.

* * * * *

专利名称(译)	电致发光显示器		
公开(公告)号	US20150262528A1	公开(公告)日	2015-09-17
申请号	US14/434851	申请日	2013-10-09
申请(专利权)人(译)	JOLED INC.		
当前申请(专利权)人(译)	JOLED INC.		
[标]发明人	TAKAHARA HIROSHI		
发明人	TAKAHARA, HIROSHI		
IPC分类号	G09G3/32		
CPC分类号	G09G3/3258 G09G3/3291 G09G2310/0286 G09G2300/0408 G09G2300/08		
优先权	2012229448 2012-10-17 JP		
其他公开文献	US9773450		
外部链接	Espacenet	USPTO	

摘要(译)

在串联连接中在COF上形成的控制线的数量减少。EL显示器包括柔性板，该柔性板包括：多个连接端子，布置在一侧，用于与形成在面板上的面板线连接；用于将柔性板内部的点与连接端子连接的端子连接线；用于连接两个或多个连接端子的串行连接线。在柔性板上：每个栅极驱动器IC的驱动器输出端子连接到端子连接线；栅极驱动器IC的驱动器输入端子连接到端子连接线或串联连接线；用于执行栅极驱动器IC的逻辑设置的控制端子分别布置在连接端子和连接有串联连接线的驱动器输入端子之间。

